



# Ham Radio Ireland



*Δεξ μερασταλ δε θραιδισιουν δεξυ δε σπιουαδ δε ραδιου δεματεαραχ*



Editor: *Steve Wright - EI5DD*      [wright14@gmail.com](mailto:wright14@gmail.com)      Vol. 3 Issue 05      October 2025



Ham Radio Ireland has been well supported and we have achieved over 10,200 downloads from our links in over 68 countries each issue.

In point of fact we are the ONLY independent Radio Magazine in Ireland geared towards the Radio Experimenter.

We repeat forthcoming events in our News Section right up to their date of operation. In this way we hope to encourage many groups or clubs to take part. If you have an event planned feel free to promote it through our Magazine

Through the Collective Communications Group, Ham Radio Ireland was re-launched in January 2025. This magazine is for all radio amateurs and electronics experimenters! We remain non political in all respects of the hobby. We will endeavour to print any radio orientated articles submitted to us.

We welcome any articles submitted for publication and encourage those who have never written for a magazine before.

Special thanks to the many who have supported this Magazine and encouraged us to re-launch it. By popular demand no less!

We publish bi-monthly and welcome any articles from Amateur Radio circles and CB or PMR 446 operators.

We primarily seek technical articles covering home built equipment, antennas, outdoor portable operating, VHF, UHF, Microwave and Satellite operation.

If you have never written an article before - NOT A PROBLEM as we will help in any way possible.

We welcome Feedback  
If you enjoyed this publication please email  
Steve EI5DD  
wright14@gmail.com

## News and Events

News and Forthcoming Events ..... 4  
Region 8 News from Northern Ireland..... 7

## Features

GI7M IOTA 2025 .....11  
From Trash To Treasure ..... 13  
The Strange Allure of Number Stations ..... 15  
TDARS Summer Outdoor Meeting .....17  
The Evolving World of Ham Radio .....18  
British Inalnd Waterways on the Air.....19  
First Contact Through QO-100 ..... 21  
A Trip To Newark HamFest 2025 ..... 25  
Guerilla Marketing for Amateur Radio ..... 29  
Stradbally Steam Rally ..... 31  
Planning Permission For Antennas ..... 33  
International Lighthouse Weekend ..... 35  
HamCation 2025 ..... 37  
IRTS HamFest 2025 ..... 40  
Tips and Topics ..... 43  
Portable Power Project ..... 44  
Railways on the Air ..... 45  
The KSOB Wire Antennas Part 1 ..... 47  
DARC Celebrates its 75th Birthday ..... 49  
DARC B44 Club Field Day ..... 47  
Gordon's Expedition To Ireland ..... 53  
Skywave Amateur Radio Club ..... 55  
My Dad's Weird Hobby ..... 56

## Submitting Items for This Magazine

We are always delighted to receive any radio related material for this magazine in word format. Pictures should be submitted in an uncompressed JPG format to ensure best quality reproduction.

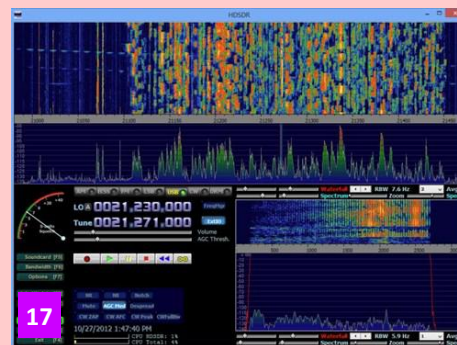

**Cover Image**  
Wayne and Alex  
Constructing 49:1  
UnUns for EFHW  
Antennas

Views expressed in this publication do not necessarily reflect the views of the Editor, those of Carrion Press, Ham Radio Ireland or EI3CC  
© EI3CC & Ham Radio Ireland



# Want to become Member

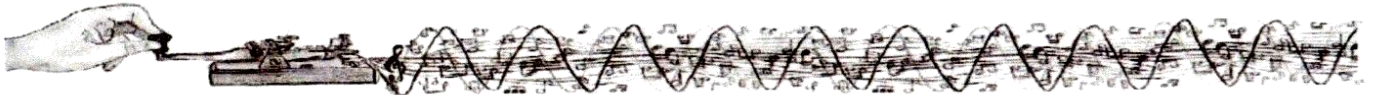

**Contact us and we can give you info on the options available.**

**this year we can now offer public liability insurance per individual.**

**Standard membership €10.00**

**Membership with cover €15.00**

**you can pay via Paypal:  
collei3cc@gmail.com  
or Revolut: @john83mj6**



# News and Forthcoming Events Planning 2025

## Freedom of association: a right in danger in amateur radio

Some IARU RI member societies have threatened their members with expulsion if they join EURAO, clearly violating freedom of association, a fundamental right enshrined in article 12 of the EU Charter of Fundamental Rights.



The "argument" put forward by these societies is that EURAO is a competitor, overlooking the fact that IARU and EURAO are also collaborators in areas of common interest, such as CEPT. And if they don't remember that, they should see the [joint statement resulting from the 2017 meeting between both organizations](#).

For this reason, EURAO does not rule out taking appropriate legal action if the case arises, beyond the crude and stupid threat.

We know that it seems incredible that this mentality is still in force today, but it is and we will do everything possible to unmask and combat it. Some would need to brush up on their **HAM SPIRIT**...

## Parks On The Air

Currently POTA has 5 official events throughout the year, as detailed below.

Events start at **00:00:00 UTC** and end **23:59:59 UTC** on the days listed:



### New Year's Week

First full week of the new year. January 1-7, 2025

Casual contacts to help ring in the new year!

### Support Your Parks

This event happens seasonally, on the 3rd full weekend of the month (Saturday & Sunday UTC). These are 'activity weekends' where the main purpose is to get out in the parks, and have as much fun as possible.

**Winter** - 3rd Full Weekend of January. January 18-19, 2025

**Spring** - 3rd Full Weekend of April. April 19-20, 2025

**Summer** - 3rd Full Weekend of July. July 19-20, 2025

**Autumn** - 3rd Full Weekend of October. October 18-19, 2025

More Info: <https://docs.pota.app/>

## We Have a Facebook Page Ham Radio Ireland



<https://www.facebook.com/groups/1437072523434876>

## EURAO European Radio Amateurs' Organization

the open global radio amateurs community



EURAO was established to promote and support the interests of amateur radio operators across Europe and around the world. For two decades, it has provided a strong voice for hams, encouraging cooperation, technical advancement, and friendship among radio amateurs globally. Whether you're chasing special event stations, participating in EURAO activities, or simply curious, thank you for stopping by. We appreciate your QSO and your interest in amateur radio! In a very short period of time, EURAO has managed to gather around itself many radio amateurs from all over the world in an exciting collective project that has received recognition from many international bodies.

Association, clubs, groups and individuals are part of this young, global and open ecosystem called European Radio Amateurs' Organization. Thanks to all for your support.

## Hams Needed To Track NASA Moon Mission



The National Aeronautics and Space Administration (NASA) is seeking volunteers to passively track the 2026 [Artemis II Orion spacecraft as the crewed mission travels to the Moon and back to Earth](#). The Artemis II test flight will send NASA astronauts Reid Wiseman, KF5LKT; Victor Glover,

KI5BKC; and Christina Koch, along with Canadian Space Agency (CSA) astronaut Jeremy Hansen, KF5LKU, on an approximately 10-day mission around the Moon. Targeted for no later than April 2026, the mission will rely on NASA's Near Space Network and Deep Space Network for primary communications and tracking support throughout its launch, orbit, and re-entry. However, with a growing focus on commercialization, NASA wants to further understand industry's tracking capabilities. If you're interested in volunteering for next year's event, all of the information can be found at [SAM.gov](#). The response deadline is October 27, 2025, at 5:00 PM EDT



WWFF, World Wide Flora and Fauna in Amateur Radio, is encouraging licensed ham radio operators to leave their shacks and go outside operating portable in Protected Flora@Fauna areas (PFF) all over the world.

## Events & Activities Planner

RSGB Convention	10th - 12th October
JOTA Scouts on the Air	17th - 19th October
Bush Valley Amateur Radio Club Rally	2nd November
YOTA Month	1st - 31st December

# News and Forthcoming Events Planning 2025

## Ham Radio Ireland Now in Two Formats

Ham Radio Ireland now comes in two formats. Recently we introduced the new Flip book format which is similar to the ARRL and RSGB digital format. Apart from reading this on line it is possible to download the PDF File by clicking on the cloud icon. We retain the traditional "Docdroid" download page where the magazine can be read page by page. Current and back issues may be downloaded in both formats and maybe accessed from:

<https://galwayvhfgroup.blogspot.com/2022/06/connacht-regional-radio-newsletter.html>



## British Railways Amateur Radio Society

The British Railways Amateur Radio Society is running special event station GB0LMR and GB2SDR during 2025 to celebrate 200 years of train travel since 1825. Starting from April, it will also be running GB2TT to celebrate the same anniversary. QSL will be via the Bureau. More information is available at [QRZ.com](http://www.brars.info) and via [\[www.brars.info\]](http://www.brars.info)(<http://www.brars.info/>)



## FCC Grants Permission to AST SpaceMobile for use of the 70cms Band

# AST SpaceMobile

The FCC's Space Bureau said in a statement that it was giving permission to AST SpaceMobile to use frequencies between 430 and 440 MHz on an emergency basis only, the regulator said its move was in direct response to overwhelming concerns raised by amateur radio operators. Citing potential interference among their issues, member societies of the International Amateur Radio Union, AMSAT, the ARRL and individual amateurs worldwide also argued that alternate UHF allocations exist for the satellites' telemetry, tracking and command functions. More than 2,500 comments were submitted to the FCC.

The FCC's action gives use of the amateur frequencies to the satellites for no more than a 24-hour period. The amateur radio 70cm band is used by hams worldwide for such applications as mobile FM voice, analogue and digital TV, digital data transmission, amateur radio satellites and weak-signal communications on SSB and CW.

AST SpaceMobile ultimately plans a full constellation of 248 satellites for broadband service from space.

AR Newsline



**Nervous Novices CW NET**  
Wednesday Evening  
21.00 local

Listen out for CQ "NNCW"  
The speed is the Net is the speed of the slowest operator



Net Controller Eamo EI7LC  
Freq is 7.035 +/- So call in and say hello



## GB2RS 70th Anniversary Celebrations Continue



Celebrations continue for the 70th anniversary of the RSGB's weekly news broadcast GB2RS.

A special callsign GB70RS will be active throughout the year operated by the radio amateurs who deliver the GB2RS new each week and RSGB Headquarters staff. Operation will be on all modes and all bands. More info from <https://rsgb.org/main/gb2rs/gb2rs-70th-anniversary/>

## Irish Net

Active not only on Sundays, but most weekdays starting at around 16:00 UTC, the informal gathering on 14.156 MHz frequently suffers from QRM during contests and DXers unaware of this long standing net of North American operators with an Irish connection. In a recent contact on 20m with W1IDP, QTH Tuscon Arizona, operator Jerry confirmed that the net now also uses the 17m band operating on 18.112 MHz moving up in increments of 3KHz. This move avoids the increased QRM on 20m and taking advantage of improved propagation conditions.

# News and Forthcoming Events Planning 2025

## Over 300 Editions of RadCom Available in RSGB Web App



The RSGB recently announced that they have added more RadCom editions to their web app. RSGB members are now able to browse through over 300 editions of RadCom magazines dating back to January 2000. Go to the web app via <https://rsgb.org/> to explore the

content. You will need RSGB membership to access this content. The RSGB Book shop offers reductions on all books purchased by RSGB members



## Scout's Jamboree on the Air

The JOTA is an annual World Organisation of the Scout Movement event in which Scouts and Guides all over the world make contacts with each other by means of amateur radio. Short-wave radio signals carry their voices to virtually any corner of the world. It is the sheer excitement of having a live conversation with a fellow Scout or Guide at some other place in the world that attracts so many youngsters to this event. JOTA is a real Jamboree during which Scouting experiences are exchanged and ideas are shared. The use of amateur-radio techniques offers an extra educational dimension for Scouts. Many grasp the opportunity to discover the world of wireless radio techniques and electronics. Thousands of volunteer radio amateurs assist the Scouts over the JOTA weekend with their knowledge, equipment and enthusiasm.

The JOTA 2025 starts at **00:00** local time on **October 17th** and runs up to **23:59** local time on **October 19th**. Note that details for use of special radio licences, operating times and allowance for Scouts to use radio transmitters may vary per country.

JOTA is the ideal opportunity to introduce the younger generation to amateur radio and it is surprising how many scouts continue their interest. If you are a station for the local scout group.

Apart from operating a station, one could organise a treasure hunt using PMR 446 radio gear to teach radio operating procedure. Other side interests might include building and testing an antenna, sending and receiving morse code and a display of homebrewed equipment.



## RSGB News Services

For your weekly fix of GB2RS, from 80m to UHF DMR. Full schedule available from [rsgb.org.uk/gb2rsschedule](https://rsgb.org.uk/gb2rsschedule).

**09:30 145.5250 FM**

**10:00 3.6400 LSB**

**12:00 DMR BM TG2354**

**19:30 DMR Phoenix TG880**

## Amateur Radio Licenses in Equatorial Guinea Temporarily Suspended



The decision was adopted in a meeting chaired by the Vice President of the Republic in charge of Defence and State Security, H.E. Nguema Obiang Mangué, together with the Prime Minister and representatives from the sectors of Security,

Defence, Finance, Transport, Treasury, and the Telecommunications Regulatory Office (ORTEL). The suspension stems from a breach in the established protocols for granting licenses.

The measure was taken following the discovery of a case in which a foreign national, operating as a radio amateur, accessed sensitive areas such as Annobón and Batete using unauthorized telecommunications equipment. This individual had obtained licenses in 2018 and again in 2025, paying a total of 531,000 F.CFA, without proper verification of the equipment's legality or the compliance of the assigned frequencies with national regulations. More info from <https://www.hamradioworld.org/>

## G QRP CLUB

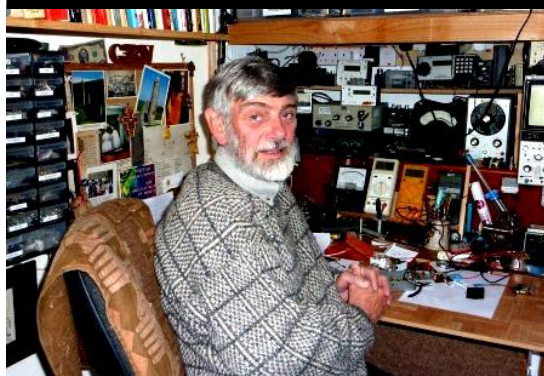

The G-QRP club was formed by Rev. George Dobbs G3RJV in 1974 to cater for those interested in low power communications after a group used to meet around 3.560MHz. In the year 2000, the club celebrated its 25th birthday and we continue growing year by year.

The club has a quarterly magazine called SPRAT, so called for Small Powered Radio Amateur Transmissions. This magazine is 2/3 full of circuit ideas and 1/3 editorial. Until his passing in 2019 it was edited by George.

It was in September 1974 that George Dobbs G3RJV started the wheels turning to make the G-QRP Club a reality. Fifty years later, the Club is going strong and we have had around four thousand paid up members for over a decade.

Membership is handled by Daphne, G7ENA, GQRP Club, 33 Swallow Drive, Louth, LN11 0DN. Subscription currently stands at €15.00 for EU members.



# **BUSHVALLEY AMATEUR RADIO CLUB ANNUAL RADIO RALLY**

Bushvalley Amateur Club are pleased to announce that this year their annual rally will be on Sunday 2nd November at the usual venue, Limavady United Football Club, Rathmore Road, Limavady, BT49 0DF. Several traders will be in attendance along with a Bring and Buy stand.

Car parking available on site and on the Rathmore Road.

Our usual on-site catering will be available

Doors open at 11:00

**WE LOOK FORWARD TO SEEING YOU THERE!**

**Proudly Supporting**

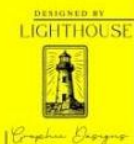

[bushvalleyarc@gmail.com](mailto:bushvalleyarc@gmail.com)   [bushvalleyarc.org](http://bushvalleyarc.org)



## Carrickfergus Amateur Radio Group

The Club meets every Tuesday evening during normal school term time from 7pm in Elim Pentecostal Church, North Road, Carrickfergus, BT38 8ND. All visitors are welcome. Regular news and updates are provided on the CARG website <https://gi0lix.home.blog/>. It is expected that the CARG Annual Rally will take place on: Saturday 25th October 2025 in Elim Church, North Road, Carrickfergus, Co. Antrim, BT38 8ND from 11:30 am - the final date to be confirmed (I will advise of the confirmed date in advance).

CARG will participate in the annual [International Lighthouse/Lightship Weekend](#) (ILLW) on 16th & 17th August 2025 adjacent to [Chaine Memorial Tower](#), Larne, Co. Antrim (WAI: D40, IOTA: EU-115, IO74CU, ARLHS NTI-004 - see the Club website for further details).

## Bush Valley Amateur Radio Club

Meets on the last Thursday of each month at 8pm in the Burnfoot Community Centre, 294 Drumane Road, Burnfoot, BT47 4NL. We now have over 20 members, and are a very active club and we hold a number of events throughout the year. Website: [bushvalleyarc.org](http://bushvalleyarc.org)  
Enquiries to: [Bushvalleyarc@gmail.com](mailto:Bushvalleyarc@gmail.com)

## West Tyrone Amateur Radio Club

West Tyrone ARC GN4OMA, has regular monthly meetings. Our meetings take place in Order of Malta Hall, Brook Street, Omagh, BT78 1DE on the second Wednesday of every month at 7.30 pm. Enquiries to: [info@wtarc.org.uk](mailto:info@wtarc.org.uk)

## Lough Erne Amateur Radio Club

Meets at the Share Village, Smith's Strand, Linaskea, Co Fermanagh at 19:30 on the first Monday of each month. More info: <https://lougherneradioclub.co.uk>

## Mid Ulster Amateur Radio Club

The Mid Ulster Amateur Radio Club (MUARC) has been active since 1965, our Club call sign is MN0VFW. Please take time to look through our FB page where you will find information on our club, activities, events and members as well as a great gallery full of images of our latest activities. Mid-Ulster Amateur Radio Club meets on the second Sunday of the month except July/August in Tandragee Golf Club at 3pm.. We organise field days for St Patricks day, Marconi weekend, 145 Alive, Sota weekend and other events. If you're in the region, and would like to take part, the club secretary can be contacted on the following email address:  
Email address: [muarc.secretary@yahoo.co.uk](mailto:muarc.secretary@yahoo.co.uk)



## Antrim and District Amateur Radio Society

The Antrim and District Amateur Radio Society meets on the 2nd Friday of each month in the Greystone Community on the Ballycraigy Road, BT41 1PW 7:30 - 9:30pm. For More information: Email [secretary@adars.co.uk](mailto:secretary@adars.co.uk)

## Ballymena Amateur Radio Club

The Club meets every Thursday night at 70 Nursery Road, Gracehill, BALLYMENA except during the summer months (June, July and August) when we only officially meet on the first Thursday night of the month, but there are some members there nearly every Thursday night. E-mail: [HKernohan@aol.com](mailto:HKernohan@aol.com)

## City of Belfast Amateur Radio Society

The City of Belfast Amateur Radio Society meets on the first Monday of each month at 8pm in the Shorts Recreation Club, Aircraft Park, Holywood Road, Belfast BT4 1SL. Contact Paul Irwin GI6FEN for more information E-mail: [paulirwin@btinternet.com](mailto:paulirwin@btinternet.com)

## Northwest Group Amateur Radio Club

The Northwest Group Amateur Radio Club, meets last Tuesday of the month at Shantallow Community Centre, Derry. Contact [nwgarc@gmail.com](mailto:nwgarc@gmail.com)

## Bangor and District Amateur Radio Society

The Bangor and District Amateur Radio Society meets on the 2nd Tuesday of the month in the Marquis Hall, Abbey St, Bangor BT20 4JE 19:30 for 20:00. We don't meet during July and August. Facebook page: <https://www.facebook.com/BangorDistrictARS/> Contact GI4JTF for more information.

## White Mountain Amateur Radio Club

The White Mountain Amateur Radio club meets at 7a, Sheepwalk Road, Castlerobin, Lisburn on Friday nights for the Amateur Radio Exam Courses, Sundays at 12pm Wednesday nights at 7pm for general radio topics, practical and social evenings. Whether interested in Amateur Radio, CB, PMR 446 or electronics all are welcomed to come along to our meetings. More information from <https://wmarc.co.uk/>

If your Club, Group or Society is not listed here, please notify us and we will add to the next issue of Ham Radio Ireland





**Merchandise**  
**Polo shirts Sweat Shirts**  
**Beanie Hats Baseball Caps**  
**Mugs and Stickers**



**Top Quality**  
**Polo Shirts**  
all sizes and colours available



**Quality Sweat Shirts**  
**Various colours**  
**and sizes available**



**Outdoor all weather**  
**Jacket.**  
all sizes available  
colours Light /Dark Grey and Navy Blue



**Beanie Hats**  
**Baseball Caps**  
**With Logo**



**Mugs And our**  
**well traveled**  
**E13CC Sticker.**

**Contact Sue, on messenger or WhatsApp**  
**for all orders**

**THE FAMOUS ML&S OPEN DAY SAVE THE DATE SATURDAY 29TH OF NOVEMBER**

**YAESU**

ML&S Officially the only Direct Factory Appointed Distributor & Repair Workshop for Yaesu Musem Products

**This month's STAR PERFORMER  
Yaesu FTX-1F  
ALL BAND ALL MODE PORTABLE**



**Another Dream Radio  
from Yaesu**

Taking over from where the best-selling FT-818 left off.

- 6W/10W on any band
- 160-70cm incl 4m
- Twin RX with any mode on either receiver
- SDR Technology and 3DSS
- 5670mAh high-capacity Li-ion battery pack
- Dual Loudspeakers
- USB ports support CAT operation, audio input/output and TX control

[HamRadio.co.uk/FTX1F](http://HamRadio.co.uk/FTX1F)

**NEW Yaesu FTM-510DE ASP  
Dual Band Mobile Transceiver**

C4FM Digital/FM 55W Dual-Band Mobile Transceiver  
The New Flagship Mobile with Super-DX & ASP for Enhanced Coverage  
Latest high-performance C4FM Digital/FM Dual-Band Mobile Transceiver, offering 55W VHF / 50W UHF output power and packed with cutting-edge features for superior communication. Designed to replace upon the successful FTM-500DE. **£549.00**



**NEW Yaesu FTM-150 ASP  
55/50W 144/430MHz FM Dual  
Band Mobile Transceiver.**

Versatile dual-band mobile transceiver offering 55W on VHF and 50W on UHF. **£349.99**



**NEW Yaesu FT-3185 ASP 85W  
144MHz VHF FM Mobile  
Transceiver.**

Powerful 2m mobile transceiver, delivering an impressive 85W of reliable transmit power, selectable at 85W, 50W, 20W or 5W. **£189.95**



**NEW Yaesu FT-3165 ASP - 65W 144MHz FM Mobile  
Transceiver.**

Robust, compact 2m mobile transceiver designed to deliver powerful performance and reliability for ham radio enthusiasts. With a 65W output, users can select from three power levels (65W/30W/5W) to suit various needs. **Limited Offer £156.00**



**FT-710 AES5 HF/6/4m All Mode Compact Transceiver.**

Perfectly sized & simple to use. **£979.99**  
With free UK mainland shipping and Yaesu hat

**FT-710 Field (no speaker) £899.00**  
**Yaesu FTM-300DE 50W C4FM/FM 144/430MHz Dual Band Digital Mobile Transceiver. £349.99**

Yaesu FTM-310 Dual Band First delivery in October **£399.95**  
FTdx101D 100W HF/6m Transceiver **£2999.00 plus FREE Speaker**  
FTdx101MP **£4099.99**  
Comes with free M-70 microphone worth **£129.95** Yaesu FT-dx10 Narrow band SDR and Direct Sampling **£1339.99**

Yaesu FT-891 HF/6m Base/Mobile **£639.00**  
**20% discount off FC-50 when bought together**  
Yaesu FT-991A All-Mode Transceiver **£1199.00**  
Yaesu FT-5DE IPX7 Dual C4FM RX Handie **£344.00**  
Yaesu FT-70DE C4FM/FM 144-430MHz Dual Band Handie **£167.95**  
Yaesu DR-2XE C4FM Repeater **£1249.99**  
Yaesu FT-65E VHF/UHF 2m/70cm Dual Band FM Handie **£84.95**



Yaesu FT-4XE 5W VHF/UHF FM Portable Transceiver **£59.95**  
Yaesu M-70 Desktop Microphone **£129.95**



**KENWOOD**

ML&S Officially Appointed UK Sole Distributor & Repair Workshop for Kenwood's Ham Radio Products



**New! Dual Band remote TM-D750E.**  
First shown at Tokyo Ham Fair 2024.  
**Coming Soon!**

**This month's Featured Kenwood  
Kenwood TH-D75e  
144/430MHz Handie**

The new TH-D75E is the logical evolution of Kenwood's popular TH-D74E duo bander. 5W on 2/70. FM & D-Star, Built-in Digipeater, APRS, Wide-band all mode receive, IF Shift function, USB-C charging port & IP54/55 approved.



**Priced at £778.99 including FREE UK mainland shipping, use code RC75.**

Kenwood TS-890S - **BACK IN STOCK!** Probably the best HF/6m Transceiver Kenwood have ever made.



Peter Hart was astounded by the receiver performance & general build quality. **This month's deal includes a FREE MC-43 microphone. Special Price £3999.95**

**ICOM**

ML&S Stock the Full Range of New Icom Products

**This month's Featured Icom  
Icom IC-7760  
200W HF/6m 50MHz Remote Head  
Transceiver**



Now In Stock, Limited Numbers.

**£5099.95**

See our YouTube Review MLandS.TV

See [HamRadio.co.uk/IC7760](http://HamRadio.co.uk/IC7760)

RC-7760 Remote head accessory for the Icom IC-7760. **£1679.00**

Icom IC-718 **£730.00**  
100W HF/6W Base Transceiver.



**IC-PW2 HF/50MHz 1kW Linear Amplifier**

A high-performance, multi-function linear amplifier is one of the key pieces of equipment for keen competition in DX hunting and contesting. Increased Linearity & Clean Transmission with the Digital Pre-Distortion (DPD) Technology (with the IC-7760) **£5095.00**



**Icom IC-905 VHF/UHF/SHF D-Star Transceiver**

The IC-905 is a versatile all-mode transceiver that covers 144-5600MHz and includes a 10GHz transverter option, providing access to VHF/UHF and SHF frequencies. **£2849.00 or CALL for package price!**

Icom CX-10G 10GHz Transverter **£1450.00**  
Or buy together with IC-905. **Call for package price!**

The Icom CX-10G 10GHz Transverter is a high-performance radio frequency (RF) converter designed for amateur radio enthusiasts and radio experimenters.

ID-52E PLUS Dual Band D STAR Digital Trsvr **£559.99**  
Icom IC-7100 HF/6m/4m/2m/70cm Base & Mobile Transceiver including D-Star with remote control head unit **NEW LOW PRICE £1095.00 and FREE UK SHIPPING**  
IC-R6E 0.100-1309.995MHz Handheld receiver **PRICE DROP £220.00 ML&S £199.00**

Icom IC-7610 SDR HF/50MHz Transceiver with **With FREE Mic** **£3199.99**

Icom IC-705 The worlds best selling All-Band All Mode Transportable 160m-70cm **PRICE!** **£1195.00**

Icom AH-705 Random wire auto tune **£299.99**

Icom IC-7300 Best selling 100 Wat 14MHz Transceiver with SSB / CW / RTTY / AM / FM **with FREE UK SHIPPING £989.95**

PTRX-7300 High quality RF interface module for the IC-7300 **£209.99**

PTRX-9700 **with FREE SHIPPING** **£280.00**

Icom IC-9700 **With FREE SP-38 speaker worth £156**

Base Station 2/70/23 all mode including D-Star **£1899.95**

Icom IC-R8600 New 100kHz-3GHz Receiver with SDR technology from IC-7300 **SPECIAL PRICE £2449.99**

Icom ID-5100 Latest 2/70 D-Star Touch Screen Transceiver **£639.95**

Deluxe Version also available for **£799.95**

**NEW! Icom AH-730 100W Remote Auto-ATU. £550.00**



Point your camera to this, the only QR Code for Ham Radio you'll ever need, it takes you directly to our web site!

Visit [HamRadio.co.uk](http://HamRadio.co.uk) for full specifications or call the team on **0345 2300 599**

**MLS**

**MARTIN LYNCH & SONS LTD**

THE WORLD'S FAVOURITE HAMSTORE

OUTSIDE THE ULEZ ZONE! Wesssex House, Drake Avenue, Staines, Middlesex TW18 2AP UK  
Tel: 0345 2300 599. International Tel: +44 1932 567 333. E-mail: [sales@hamradio.co.uk](mailto:sales@hamradio.co.uk)  
Opening Hours: Mon - Fri: 8.30am to 5pm. Sat: 9am to 4.30pm

£&E



**SOMETHING FOR THE WEEKEND SIR?**

Tune in every Friday to [www.MLandS.tv](http://www.MLandS.tv)  
[https://www.youtube.com/@Martin\\_Lynch/videos](https://www.youtube.com/@Martin_Lynch/videos)



Keep up with our latest **USED EQUIPMENT, SPECIAL OFFERS & NEW PRODUCTS** YouTube

# Looking for the latest releases at ML&S? Click: [www.HamRadio.co.uk/new-release](http://www.HamRadio.co.uk/new-release)

## Hiberling Ultra-premium HF/VHF Transceiver



Hiberling PT-8000A HF/VHF Transceiver handcrafted in Germany to the highest engineering standards ..... **£13249.00**

Hiberling HPA-8000B  
1kW Power Amplifier. 160/80/40/30/2  
0/17/15/12/10/6/4m bands. All-mode:  
AM/FM/SSB/CW. Internal power supply:  
200-260V ..... **£5800.00**



## Power Supplies



**Samlex SEC-1235P-M Desktop Switching Power Supply**  
The Samlex SEC-1235P-M is destined to become THE premier lightweight 13.8 VDC desktop power supply, offering updated features and upgraded performance and ratings. .... **£174.95**

**Samlex SEC-1235G 30 Amp Switch Mode Power Supply**  
This highly efficient AC-DC power converter provides a highly regulated output DC voltage of 13.8 Volts at 30 Amps with an AC input of 230 Volts, 50Hz. .... **£121.95**



**Two-year warranty on all MyDEL PSUs**

**MyDEL PS-30SWVI (PS-30)**  
A high power DC regulated Switch Mode power supply, providing up to 30amp maximum current. Comes with Over Voltage, Current Limiting and Short Circuit Protection. .... **£79.00**



**MyDEL MP-50SWIII**  
Super Lightweight Metered PSU 48-50 Amp, 9-15V DC power supply ..... **£139.99**

**MyDEL 30A Linear Power Supply**  
The QJE QJ1830SC is a high-quality 30A linear power supply designed to provide reliable and stable DC power for a variety of radio communication and electronic applications. .... **£109.99**



**Pro Audio Engineering Kx33**  
Low-RFI AC Power Supply for HF Transceivers  
Small, light, easily portable high-power DC supply which has low AC input to DC output coupling. This is critical to minimise RFI due to common-mode currents often found with temporary antennas such as end-fed or verticals. **£69.95**



**New MyDEL Battery for Mobile Operation**  
12V 50Ah LiFePO4 Lithium Battery... **£129.95**



10A Charger for above ..... **£64.99**

**Shackmaster Power 600**  
Rig Expert 13.8V/40A Power Supply.  
Compact Desktop Power Supply sets the new standard for high quality. .... **£419.95**

**13ft/400cm Air Cushioned TRIPOD**  
Air Cushioned Light Stand-Integrated with the air cushion to protect your device from abrupt drops.  
Optimum supporting tool for heavy photography softboxes, strobe lights and Bowers video lights ..... **£95.00**

**Heil Sound** ML&S are the official UK importer for Heil Sound headphones and microphones



Pro-Set 7 Headphones ..... From **£269.95**  
Pro-Set 6 Headphones ..... From **£134.95**  
Pro-Set IC Headphones ..... **£169.95**  
Pro-Set Elite 6 Headphones ..... **£174.95**  
Pro-Set Elite IC Headphones ..... **£189.95**  
Pro-Set 3 Headphones ..... **£109.95**  
PR-781 Microphone ..... **£189.95**  
PR-40 Microphone ..... From **£299.95**  
PR-40 Microphone New All Black Version ..... **£299.95**

**403A Noise Cancelling Headset NC-1 BT**  
Offers ideal suppression of external noise in any situation. Thus, thanks to ANC (active noise cancelling), you can perfectly concentrate on quiet and weak signals even in noisy environments and are less distracted. In hectic contest operations, this can be a clear advantage! ..... **£279.95**

**Shack Clock. Special Offer £19.99**

**New Bits & Bobs! See Web for info.**  
EFHW KIT 200W 49:1 Unun for making your own end-fed half wave antenna. .... **£85.00**  
SDR Port Switch 0-70MHz 100W RXin RXout ..... **£199.00**  
Aziloo DF-72 Antenna System ..... **£625.00**  
Triple base magnetic mag mount SO 239 ..... **£45.95**

## HackRF Pro SDR Platform: A Next-Gen Open-Source Transceiver



The latest offering from Great Scott Gadgets, the **HackRF Pro**, delivers impressive performance in a compact package. Covering **100kHz to 6GHz** with transmit and receive capability, it is a versatile and open-source platform designed for serious radio experimentation.

Available from early September 2025 for only **£312.00**  
Pre-order on our website, see [HamRadio.co.uk/hackrfpro](http://HamRadio.co.uk/hackrfpro)

**Anyone AT-588**  
4m Transceiver  
70MHz.



**£149.99**

**Anyone AT-6666Pro**  
10m Mobile Transceiver  
AM FM SSB 10m Radio  
28-29.700MHz  
80W.  
Special Price



**£204.95**

## Hear those weak signals with bhi DSP noise cancelling products designed and built in Great Britain.



**NES10-2MK4**  
New NES10-2MK4 amplified DSP noise cancelling speaker. .... **£139.95**

**Dual In-Line**  
Dual channel amplified DSP noise eliminating module. .... **£189.95**

**DESKTOP MKII**  
Amplified DSP base station speaker - 10 Watts audio. .... **£239.95**

**NEDSP1901-KBD** Pre-wired low level retrofit audio DSP noise cancelling module. This module replaces the popular NEDS01061-KBD that many Yaesu FT817/FT-818 users have installed over the last 18 years. .... **£129.95**

**Compact In-Line** Compact DSP noise cancelling module with improved DSP algorithm giving even better noise elimination. .... **£190.00**

**ParaPro EQ20** Audio processing unit ..... **£249.95**

**ParaPro EQ20B** Audio processing unit (Bluetooth version) ..... **£220.00**

**BHI NCH** Active noise cancelling headphones ..... **£29.95**

**BHI HP-1** BHI Wired stereo communications headphones ..... **£19.99**

## Digirig Lite rev 1.2

A minimalistic version of Digirig with the same audio code as regular model of the interface but without serial port.

- Combines audio codec and PTT switch
- Supports PTT by GPIO3 of CM108 audio codec
- Supports VOX PTT by the tone on the unused right channel (experimental)
- Works with all major OS flavours: Windows, MacOS and Linux
- Uses a single TRRS connector compatible with existing Digirig audio cables
- Growing collection of pre-made cables including popular Icom, Yaesu, Elecraft, Baofeng, Xiegu transceivers
- Isolation can be easily added using a USB isolator dongle ..... **£47.95**

## DigiRig Isolator

Eliminate audio noise caused by ground loops by isolating your PC from transceiver. .... **£29.95**



## ZUMSPOT Mini 2.4" OLED LCD Pi Zero 2

Single band UHF Modem, Raspberry Pi Zero 2 depending on availability), 2 part ZUM case, SD Card loaded with Pi-Star ready for you to configure, use with your compatible digital radio. .... **£178.00**



## ZUM Radio Elite

3.5 LCD small and efficient Multi-Mode Digital Hotspot High performance 32-bit ARM processor. Fully assembled and tested in exclusive custom injection molded case. Includes a Raspberry Pi 4. Supports DMR, P-25, D-Star, YSF, NXDN, POCsAG and M17. Onboard LEDs to show status (Tx, Rx, Status and Mode). Up to 10mW RF transmit power. SMA antenna connector, UHF antenna included. Includes pre-programmed and pre-configured SD card with Pi-Star. The open source firmware (MMDVM) is pre-loaded. Built-in 3.5" LCD screen. Includes 3A USB-C power supply. 1 year warranty ..... **£255.95**



## ML&S RANGE OF LINEAR AMPLIFIERS

### ACOM 1400S

**Solid-State 1.8-54 MHz Linear Amplifier**  
**£3495.00**

The ACOM 1400S is a state-of-the-art amplifier covering all amateur bands from 1.8 to 54MHz. It comes with a new compact Touch-Screen Remote Control Unit. The proven ACOM 06AT tuner is the optimal option for use with ACOM 1400S. Both devices share the same front panel design and will look magnificent in your shack.  
ACOM 1400S amplifier is based on the latest LDMOS transistor technology. The final PA stage uses a rugged 65 V LDMOS transistor for heavy operation modes. The amplifier as standard is equipped with an Ethernet interface and thus can be remotely controlled via the Internet through the integrated Web interface.



### Acom 500S

**500W 160m-4m 500W Linear Amplifier IN STOCK**



The ACOM 500S is a state-of-the-art linear power amplifier that covers all amateur bands from 1.8 through 70.5MHz and provides 500W rated output power (PEP or digital) ..... **£2199.00**

**New Acom 1003** HF + 6m Linear Amplifier ..... **£2700.00**

**Acom 2100** 1.8-54MHz Linear Amplifier ..... **£3420.00**

**Acom 2020S** 1.5kW 160m-6m Solid-state ..... **£6779.00**

**Acom 1010** 160-10m Linear Amplifier ..... **£1985.00**

**Acom 1000** 1kW 1kW PEP/CW 1.8-55MHz ..... **£2449.00**

**Acom 2000A** 1500-2kW output auto with 2x4CX800A ..... **£5295.00**

**Acom 700S** 700 Watts PEP or Carrier output ..... **£2399.00**

**Acom 1200S** Same as 700S but with 1kW output ..... **£2799.00**

**Acom 1500** HF+6m Linear Amplifier ..... **£3049.00**

**Acom 06AT** Automatic Antenna Tuner & Switch ..... **£999.95**

**SPE Expert 1.5K-FA Taurus**

Solid-state linear amplifier at the forefront of RF engineering. It provides a solid 1.5kW of output with exceptional linearity, efficiency, and robustness. Integrated with a built-in power supply and a highly capable automatic antenna tuner. .... **£4399.99**

## Nissei Power Meters

### Nissei DG-103 MAX

Digital Display SWR/Power Meter. This digital SWR & Watt meter is highly accurate for measuring Forward Power, Reflected Power, & VSWR ..... **£149.99**

**DG-103** Digital Display SWR/Power Meter ..... **£131.95**

**DG-503Max** Digital Power Meter ..... **Only £159.95**

**DG-503** Digital Power Meter ..... **Only £109.95**

**NS-2230D** 30Amp PSU, Front Power Pole Connectors ..... **£84.95**

### MyDEL Nissei Compact in-line meters

**RS-50: £65.95. RS-70: £76.95** The RS-50 (120W 2m & 70cm) & 70 (200W 160m-6m) are compact in-line meters that present power and SWR on a digital backlit LCD display.



## Lido In-Car Mounting Kits

**Lido Cup Holder Mount. £31.20**

This is just one example of the many available in store.

See web for our full selection

## ML&S Official Distributor of MAT products

These beautifully crafted precision instruments offer performance and dependability.

For the full range, see [www.HamRadio.co.uk](http://www.HamRadio.co.uk)

**mat-S1500** 1500W 1.8-54MHz SWR & Power Meter for HF Shortwave Radio with a 4.3inch LCD ..... **£340.00**

**mat-705 Plus**

Auto ATU for Icom IC-705 with Internal Li-Ion battery ..... **£169.96**

**mat M-200** High Speed Auto Tuner for Icom & Kenwood ..... **£229.99**

**mat Y-200** 160-6m High Speed Auto Tuner for Yaesu ..... **£214.96**

**mat-10** Automatic Tuner For QRP Transceivers ..... **£179.00**

**mat-30** Automatic Tuner For Yaesu Transceivers ..... **£139.95**

**mat-180H** Automatic Tuner For ICOM Transceivers ..... **£139.95**

**mat-705Plus** Micro automatic ATU for IC-705 ..... **£169.95**

**mat-K100** Automatic Tuner for KENWOOD & ICOM ..... **£136.96**

**mat-125E** General Automatic Antenna Tuner ..... **£139.95**

**mat-40** Automatic Antenna Tuner ..... **£229.95**

# GI7M IOTA 2025

Charlie GI4FUE,  
Richard GI4DOH,  
Keith GIOSSA, Ken  
GI6KDN, Peter MI5JYK  
and John G4LKD, as part  
of the 7M Contest  
Group, set up GI7M on  
Rathlin Island (EU-122)  
for the 2025 IOTA  
Contest. This is the first  
time we have done IOTA  
from Rathlin Island but  
some of the team has  
operated together  
previously as GM7M  
from the Isle of Arran  
(EU-123) and as CR5CW  
from Culatra Island (EU-  
145).



*The GI7M Team*

In the past we have tended to enter the high-power section of the contest but that brings a whole set of problems with the closeness of the two stations. We opted this year to do a low power (100 watts) multi-two DXpedition station and the radios were a pair of Elecraft K3 transceivers – well known for their ability to work together. For antennas we had a DX Commander (40m to 10m) and 80m inverted V for the SSB station and a rotary dipole (20m to 10m) on top of a 10m aluminium Spider beam pole and inverted V 40m/80m dipole for the CW station.

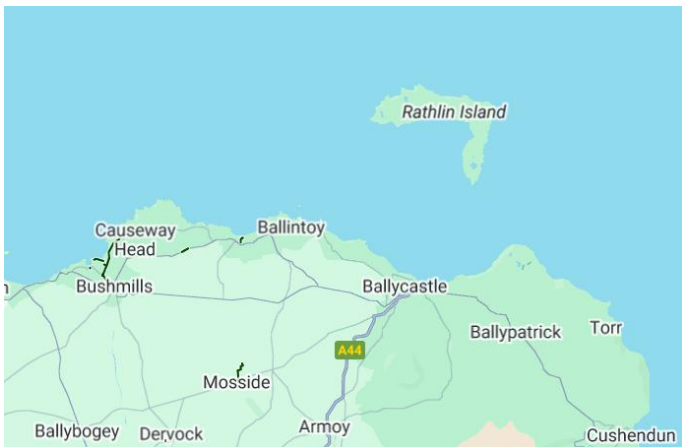

As five of us live in Northern Ireland, this was an easier option for us this year. Two of the team were blue badge holders, this made transporting the equipment somewhat easier as we were able to take two vehicles on the ferry. The ferry crossing from Ballycastle on the Northeastern Northern Ireland coast is just over 30 minutes and we fortunately had calm crossings both ways.



*GI7M team with the antenna*

# GI7M IOTA 2025

The idea that the rotary dipole was horizontally polarised and the DX Commander was vertically polarised was a deliberate choice to minimise pickup between the antennas. The CW station also had automatically switching bandpass filters for each band and this all worked well regarding interference between the stations. We also had the advantage that the coax runs for each station were well away from each other, so mutual pickup was at a minimum. Propagation conditions appeared to be down a bit for the weekend but both stations performed well.

This was a new location for us with one or two surprises in the layout that weren't apparent from satellite images. The plan to use a drive-on mount for the Spider beam pole was somewhat thwarted by the fact that there was no vehicle access to the patio area. Fortunately, we had sufficient ballast by way of the team members to keep the base secure until the rotary dipole was fully extended and guyed. The field to the side and behind the building was steeper than we had anticipated but we just got on with the job of getting the antennas up.



*GI0SSA at the CW Station*

While we all brought a quantity of food, we went down to the chip shop/bar of the Friday evening and then a quick visit to the shop on the Saturday morning to top up with some essentials.

Our logging app for the contest was the N1MM+ logger. This has the advantage of allowing the stations to be networked together so a copy of the log is kept on both machines for security. It also means that both stations can see how the other one is performing at any moment in time. There is a facility to send messages between the stations so we could arrange band changes if we didn't want to go to the effort of visiting the other station. This all worked well for us.

Overall we had over 1,700 QSOs, with the CW station being somewhat ahead of the SSB one. We will have to wait until the results are published to see how accurate our logging was but a good effort was made by both stations and all involved.

Taking down the antennas was somewhat faster than putting them up in the first place and we completed all that before a couple of heavy rain showers. The storeroom gave us a bit of shelter for packing things up properly. We were tired but also hungry and thirsty and the local hotel was an excellent choice for a celebratory meal and refreshments on the Sunday evening.

Monday morning was a slightly earlier start to allow for final pacing and loading up of the vehicles. We were in plenty of time for the 8.30 ferry back to Ballycastle. Our general feeling was that this was a successful mission, and we will certainly consider using this venue again in the future. We know the form now so it will be easier next time •

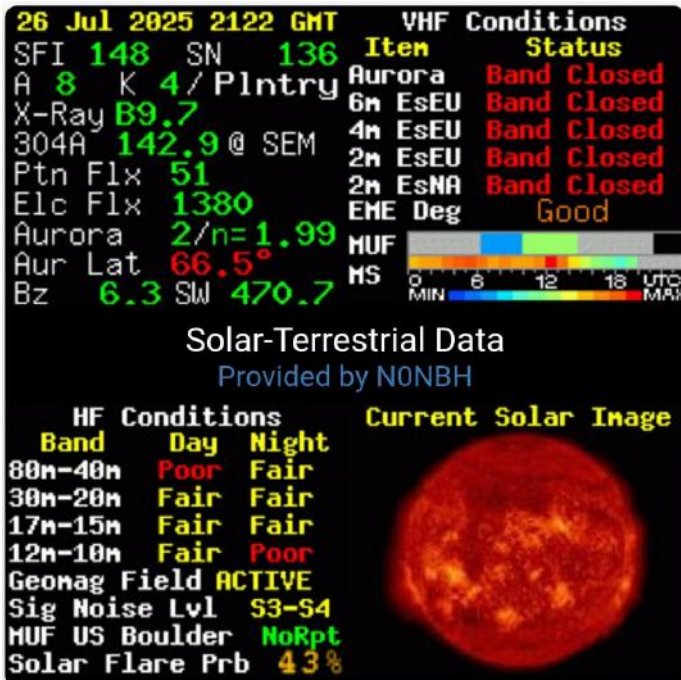

*Propagation Conditions were down for the weekend*

The building consisted of two self-catering apartments, so we assigned the upstairs one to the SSB station and the downstairs one to the CW station. Furniture was suitably rearranged with regards to power access and windows for cable entry. Conveniently, there was a storeroom where we were able to dump packaging material out of the way. There was sufficient, if not excessive, space and we settled in quickly.

*Richard White G4DOH*

[richard@ramfihaz.co.uk](mailto:richard@ramfihaz.co.uk)

# From Trash to Treasure

I was at a radio rally a few years ago and as we all do, I had a rummage in some of the boxes under the tables, I always have a look in these areas as you never know what you might find hidden away that the stall holder deems not worthy of a place on the selling table. After pulling and poking about I came across a Yaesu YS-2000 SWR meter, well the case and meter which were in separate pieces. I had an interest in the meter and not the case, I could see the meter was in good condition and worthy of rescuing regardless of the other bits.

I enquired as to the cost of the bits and I was informed €5.00 and it was mine as long as I purchased a Yaesu YP150Z dummy load as well.

As for the rest of it, I decided to strip down each item and check it and clean it. First off was the selector switch; these are built in an era when they clunk on selecting a setting. They would outlive me and many more as quality back then was just standard.

The selector switch is a stacked switch and the clunk on selection is via a small ball bearing (yes you heard that right bearing) as per picture. These can rust and stick and as a result, the switch will become hard to operate so it has to be checked when the switch is stripped. As said before, it is a layer switch so take plenty of photo's of it when stripping and lay out the components in order of removal that way it is merely reversal on rebuilding.

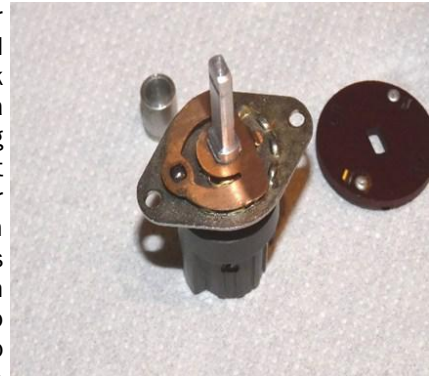

A good spray with switch clean and a wipe with clean dry cloth is usually good for a few more years of operating also at this point remove the cut wires and resolder ready for new wires later on down the line. The small tubes are the spacers between each layer and the nut and bolt hold the switch in one piece.



Once I had all the switches and knobs cleaned, it was time to go back to the meter and try and work out what had been cut from its internals.

A bit of scrolling on google produced very little on images of its internals and only having a schematic diagram I could see I was missing the complete coupler



Yaesu YS-2000 Peak Reading Watt Meter

I acquired to two items and headed home happy with my finds as I have a full Yaesu 101ZD set up and these would add to the line up and keep the Yaesu vintage theme.



A few days later I pulled the meter from the rally bag and had a good look inside and out to see what id try and salvage, on inspection internally I noticed various cut wires and missing parts.



Externally it looked good the front panel was scratch free and all knobs were still in place, at this point it seemed a shame to break it up for bits and render it again to the sin bin of bits.

Internally some parts of the unit were cut out this left a void in the middle of the meter and I would need to call upon the god google for help to find out what was missing.

# From Trash to Treasure

board this also housed the connectors for the coax connectors.

The search was on for possibly a damaged meter with an intact coupler board that I could salvage, the search drew a blank as these meters are quite rare so not many about for scrap.

I did however find another option in the form of a kit you build yourself, so off went my €25.00 and in no time the kit arrived from Russia, the instructions were easy to follow so I set about building up the board for the meter.



could see that the board would need a metal cover to screen it from outside interference so out came an old biscuit tin a bit of plywood and memories of my days in school and being thought how to solder tin.

An Hour or so later my tin origami and a fat soldering iron produced a tin screening box and in no time it was fitted it was fitted in place, On to soldering all the wires back in place as per Diagram and fingers crossed it would work.



The next job was the case, it was somewhat shabby so I decided id strip it as it had rusted in places and needed revamping if it was to match all my 101 ZD line up. I stripped off all the paint with an acid paint stripper and then sanded away any rust then I wiped the case with paint thinners and applied three light coats of Rust-oleum winter grey paint which is as near a match to the original Yaesu grey.

Once the paint had dried I assembled the meter and I must say it looked like a new meter But ... did it work? Well of course it did and still does, I am happy I managed



to save a great old meter from the trash can, at times I look over at it and remember every detail of rebuilding it and knowing its now keeping my gear safe when I need it to.

It now resides next to the YP150z dummy load / power meter and is in keeping with my vintage station •

John Tubritt - EI3HQB

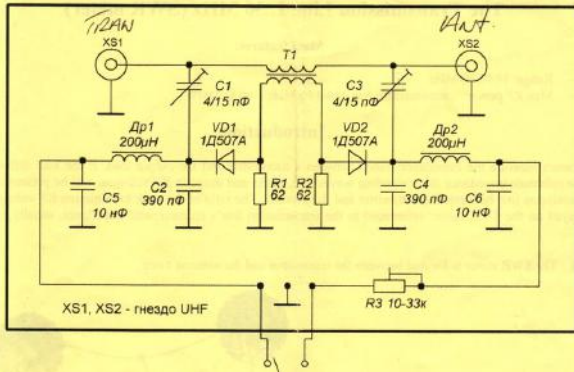

The board its self is straight forward to follow and in no time the main components were soldered in place

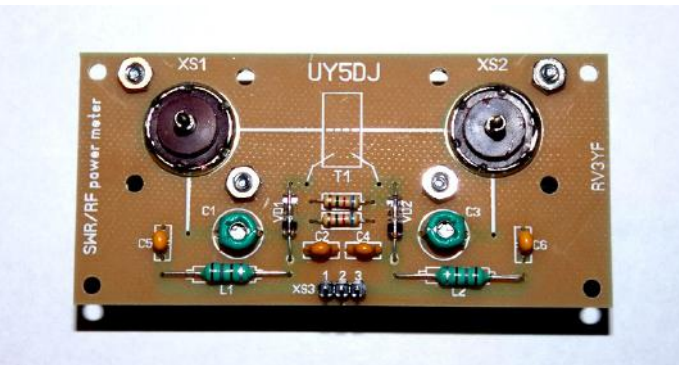

The next task I found a bit tricky as I have builders hands and this needed the skills of a surgeon to get a number of turns around a tiny ferrite ring and placed on the board (I used a glue gun to stick it to the board) once soldered a piece of coax then bridges the two coax pins but leaving a small section of screening on the coax in the ring.

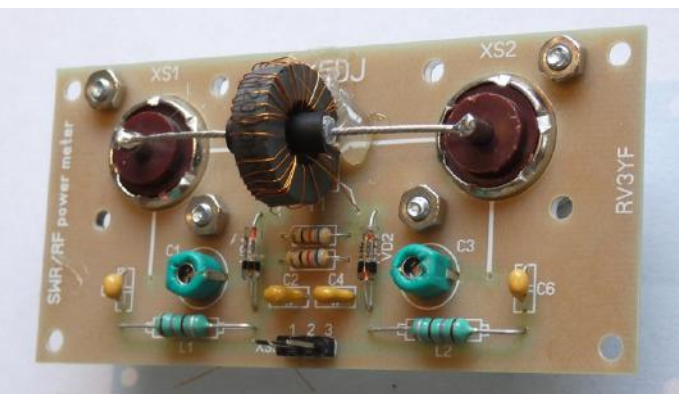

That then is the board built and in the meantime I had located a poor image of the internals of a meter so I

# The Strange Allure of Number Stations

For amateur radio experimenters and shortwave listeners, few signals are as enduring and as oddly compelling, as number stations. And none is more famous than the Russian “Buzzer” on 4625 kHz. UVB-76,

## A personal note from the bench

As a radio experimenter, I started off listening to my Dad’s shortwave radio when I was young. I loved tuning around the bands, catching amateur radio broadcasts, and every so often stumbling onto those odd stations sending strings of numbers. Later I learned they were spy stations transmitting to undercover agents in other countries. And that’s how my fascination with number stations began.

## What are number stations?

“Number station” is the hobby shorthand for shortwave transmitters that send structured, one-way traffic, most often groups of numbers or codewords, intended for distant, unknown recipients. The classic explanation is clandestine or military communications protected by one-time pads or other procedures, trivial to receive, impossible to decode without the key. The genre dates to the Cold War, but monitoring shows that many are still active today.

Numbers stations have been given identity numbers by shortwave listeners. In practice, monitors use a simple catalogue: a leading letter for language or mode (E = English voice, V = other-language voice, M = Morse/CW, S = digital), followed by a number (e.g., E11, V13, M12). Many also carry nicknames like “Buzzer,” “Pip,” or “Squeaky Wheel.” You’ll see those labels throughout this article and in community logs.

## Meet “The Buzzer” on 4625 kHz

The most listened-to of them all is the Russian station nicknamed The Buzzer. You’ll find it almost any time of day on 4625 kHz, typically in USB with carrier. When no message traffic is pending, it emits a metronomic buzz that functions as a channel marker, keeping the frequency occupied and the network synced. At irregular intervals, the buzzer cuts out and a Russian voice reads short, formatted messages: call signs, numbers, and code words.



## Featuring Russia’s “Buzzer”

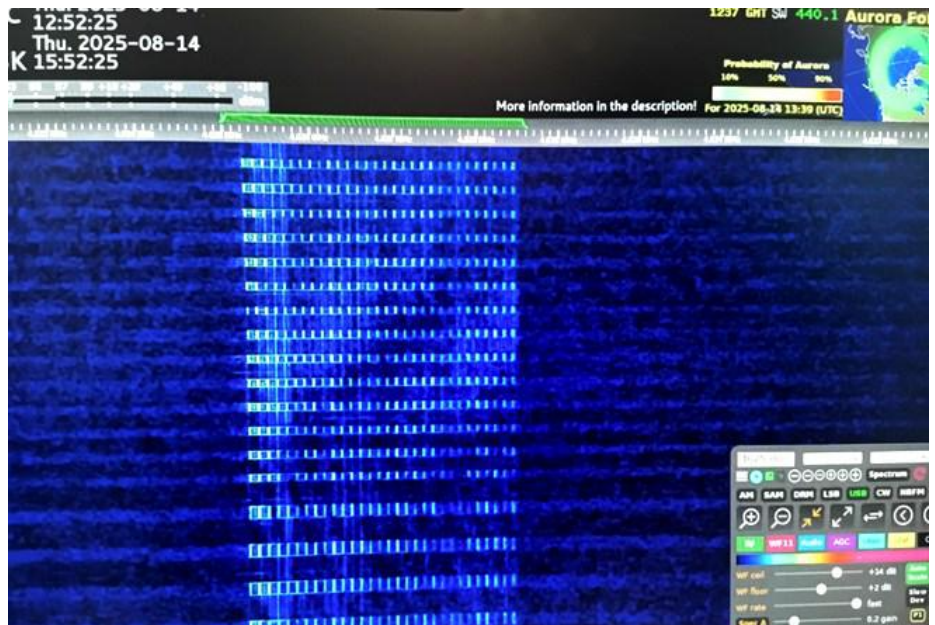

## What we (think we) know

- Role & network: Open-source monitoring points to a Russian military command network with several traffic types; messages are terse, procedural, and clearly templated.
- Where it comes from: Historically associated with sites near Moscow and St. Petersburg; multiple transmitters appear to be used.
- When to hear voice traffic: Messages can appear anytime, but weekday Moscow business hours are the best bet.
- Interference folklore: On rare occasions, music or prank audio has appeared on-channel anomalies that only add to the mythology.



## How to listen (HF set or SDR)

Quick start: Tune 4625 kHz USB. Begin with ~2.4–3 kHz audio bandwidth, AGC slow/medium, and go easy on noise reduction (it can “pump” on the buzz tone). The marker is unmistakable once you’ve heard it.

## No HF radio handy?

Try a web receiver such as a WebSDR or KiwiSDR node. Or get a cheap SDR dongle on Amazon, then download the free SDR software on line like HSDR

# The Strange Allure of Number Stations

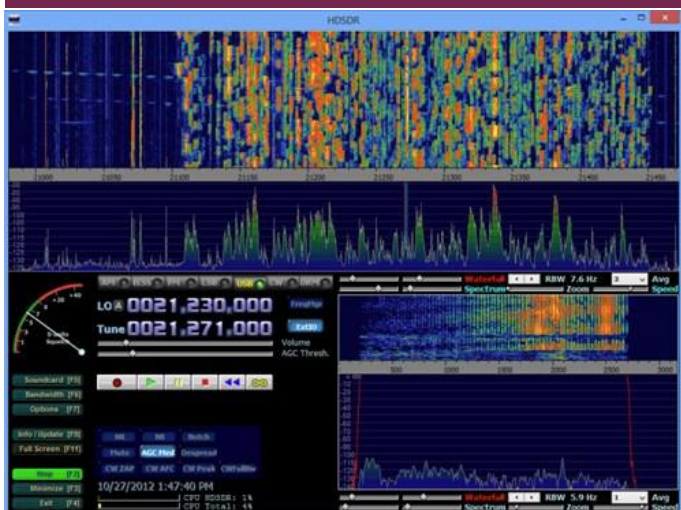

<https://www.hdsdr.de/screenshots.html>

They cover 0–30 MHz, are free to use in a browser, and many in Europe copy the Buzzer day and night.

**Antennas:** A 30–40 m horizontal wire or a magnetic loop works nicely at 4.6 MHz. Indoors, a small active loop can tame local QRN. In Ireland/UK, expect the marker most hours; long-haul reception usually improves after sunset when D-layer absorption drops.

**When to watch closely:** Weekdays, 07:00–17:00 Moscow time (UTC+3) tend to be most productive for voice messages—though nothing about this station is guaranteed.

## What exactly are those voice messages?

They follow consistent templates. You'll typically hear a collective callsign, an identifier (digits), and one or more message groups that include a code word plus digit pairs. Without the cryptographic key the content is opaque, but recognising the structure is half the fun, and a great way to compare notes with other monitors.

## Experiments for hams & SWLs

### 1) Proper logging

Keep **UTC time, mode/bandwidth, SNR/RS, location, and exact text heard** (Russian phonetics help). Share logs with the monitoring community for pattern analysis.

### 2) Audio & spectrum capture

Record audio and save waterfall screenshots around message time. The carrier/USB signature is distinctive and makes later study easy.

### 3) DIY direction finding (TDoA)

KiwiSDR's Time Difference of Arrival tool lets you triangulate HF sources using multiple receivers. It's imperfect but hugely educational—ideal for club nights.

### 4) Parallel channels

When a 4625 message lands, sweep nearby frequencies and known CW channels. You'll sometimes catch simultaneous key-ups that reveal how the network is engineered.

### 5) Propagation study

**Log SNR vs. MUF/LUF** around 4–6 MHz for your QTH across seasons. You'll see why winter nights shine and summer days can be mushy on 65 m.

## Myths, realities, and etiquette

Not a “doomsday switch.” The Buzzer is far more mundane than the internet legends suggest, think routine military signalling, not apocalyptic triggers.

Pirates and pranksters: Note them, record them, but don't amplify the noise.

Legal note: Receiving is generally lawful in many countries, but check local regulations, and never retransmit or interfere.

## Why these matters (beyond the mystery)

For experimenters, stations like the Buzzer are superb real-world beacons: stable, long-lived signals perfect for testing antennas, front ends, filters, DSP chains, and propagation models. For SWLs, they're a living museum of state-level HF networks still operating in the smartphone era, RF history you can hear at home.

## Quick-tune cheat sheet

Frequency: 4625 kHz

Mode: USB (often with carrier)

What you'll hear: Constant buzz most of the time; occasional Russian voice with call signs, numbers, code words

Best monitoring window: Weekdays, Moscow daytime (UTC+3)

Tip: Keep the recorder running, you'll catch the message you didn't expect.



## Other number stations worth chasing

**The Pip (Russia)** — Sibling to the Buzzer: rapid “pip” marker with terse voice traffic. Commonly around 5448 kHz by day and 3756 kHz by night (USB).

**The Squeaky Wheel (Russia)** — Distinctive “squeak” idle tone; voice traffic resembles other Russian nets. Often heard near 5473 kHz and occasionally 3828/3363.5 kHz (USB/CW).

**HM01 (Cuba)** — Hybrid Spanish voice plus digital RDFT file bursts. Rotates multiple daily slots across roughly 5–12 MHz. Great for waterfall captures.

# The Strange Allure of Number Stations

**VC01 “Chinese Robot” (PRC-attributed)** – Very fast female Mandarin numbers ( $\approx 3$  digits/sec) on shifting USB channels; best via East Asian SDRs.

**V13 “Star Star Broadcasting Station” (Taiwan)** – Mandarin female voice with a flute intro, typically above 8 MHz in USB.

**E11 “Oblique” (Poland)** – English-language numbers; irregular but still turns up.

**E07 “English Man” (Russia)** – Male English voice variant associated with the Russian family of stations.

**Historical: E03 “Lincolnshire Poacher” (UK)** – Iconic interval signal, long off-air, but useful for comparing classic formats.

## Conclusion – why I still listen

For me, this all started with my dad’s shortwave set and the thrill of stumbling onto those strange voices counting into the night. Decades later, I’m still hooked, not

because I expect to “crack” anything, but because number stations are perfect playgrounds for experimenters. I use them to benchmark antennas, stress-test DSP chains, teach newcomers about ionospheric quirks, and remind myself that radio is a living, breathing craft.

If you’ve never tried, make it simple: park on 4625 kHz USB, hit record, and keep a clean log. When the Buzzer breaks into voice, note the exact time and wording. Then compare with other monitors, try a loop vs. a long wire, and see how your copy changes with season and sun. That blend of mystery and method is the magic for me, and I suspect it will be for you too •

See you on the waterfall.

*Lez Ferguson EI4GEB*

<https://www.qrz.com/db/EI4GEB>

## TDARS Summer Outdoor Club Meeting With Special Guest

The Telford and District Amateur Radio Society committee plans regular outdoor practical meetings making use of the local village-owned field instead of sitting inside every meeting. For the evening of 16<sup>th</sup> July 2025 a special guest was invited along, Callum MOXXT “DXCommander”, who kindly drove over from the West Midlands. The evening was a lovely warm dry summer evening and 32 members and visitors came along to see Callum operate a station and demonstrate his latest aerial, telling the club about its design and use.

It was running off two 12.8V 100AH LiFePO4 batteries giving capability for QRO having 800w, from a 12v amplifier. Callum operated on 40m working around the UK and near Europe but suffered from some noise from houses nearby, he had plenty of successful contacts. This was all live streamed on Callum’s Youtube channel.



This time of year its light until late and the evening was a success, all elements came together – at the end gear was packed away and some members retired to the pub for debrief.



The field is well kept for local children and adults to use and is good for trying out HF antennas, albeit in a shadow of the Wrekin Hill. The club is fortunate to have access, if pre-booked with the village committee. Also the field is accessed through the car park of a very nice pub, The Huntsman, Little Wenlock.

The club put on a selection of sandwiches and drinks and members chatted, caught up and planned future activities, like the TDARS HamFeston 31st August. Callum brought along his latest ‘Venture’ POTA antenna and his station was up and running in around 20 minutes.

The club thanks Callum for coming along.

Telford and District Amateur Radio Society information from [secretary@tdars.org.uk](mailto:secretary@tdars.org.uk)

*David Harris - GOCER*

[davekh@gmail.com](mailto:davekh@gmail.com)

## Tradition Meets Technology

Ham radio, or amateur radio, is undergoing a significant transformation. It's moving beyond its traditional roots of building transmitters and tuning dials to embrace a dynamic blend of classic techniques and cutting edge technology. This evolution is crucial for attracting new enthusiasts, especially younger generations, and highlighting how ham radio integrates seamlessly with science, technology, creativity, and even social media.

### Key Trends Shaping the Future

**Computers and Software-Defined Radios (SDRs)** SDRs are revolutionising ham radio by offering unparalleled flexibility. Unlike traditional radios with fixed capabilities, SDRs can be updated and adapted through software; every update is like getting a new radio. This allows amateur radio operators to experiment, design their own radio setups and software, and explore innovative communication methods.



**Integration with the Internet** The Internet is enhancing the ham radio experience. Online platforms now make it easier to log contacts, send QSL cards, remotely control radios, and share information. This integration doesn't replace traditional radio communication; it expands its reach and convenience.

**Emergency Communication** Ham radio remains a vital tool for communication during emergencies when other systems, like cell towers and the internet, fail. Its independent operation makes it a reliable lifeline in disaster situations and will continue to do so.



**Youth Engagement and Education** Engaging young people is key to the future of ham radio and without it our hobby could die off. By connecting with local clubs and participating in events like "Jamboree on the Air" (JOTA) and "Youngsters On The Air" (YOTA),



students can learn valuable skills.

- Learning to track satellites
- Building antennas
- Experimenting with coding and digital signals

Mentorship and accessible entry points are crucial for inspiring the next generation of engineers, scientists, and innovators.

### Adaptation and Innovation

Throughout its history, ham radio has continually adapted, evolving from Morse code to voice, and from analogue to digital. Its continued relevance depends on embracing new technologies while honouring its rich traditions.



### Challenges and Opportunities

**Attracting Younger Operators:** To appeal to a younger audience, ham radio needs to be presented as exciting and relevant, not outdated. Connecting the hobby with modern interests like space exploration, satellite technology, DIY electronics, and coding can significantly boost its appeal.

### Navigating Regulations:

While regulations are essential for maintaining order on the airwaves, they also need to foster innovation and remain welcoming to newcomers. A balance between safety standards and flexibility will encourage community



growth. One major step we could take here in Ireland would be to introduce a novice licence.

### Balancing Tradition with Modernisation

Think of ham radio as a classic car that benefits from modern upgrades. The goal is to preserve its heritage while integrating new components to keep it practical and exciting for today's world.

### Conclusion

The future of ham radio is bright, driven by adaptation and innovation. By embracing technology, actively welcoming young people, and continuing to demonstrate its value in emergencies, social connection, and everyday communication, ham radio can thrive for generations. As amateur radio operators, it is our responsibility to embrace these changes and encourage the next generation to carry the torch forward, ensuring the hobby's continued vitality.

Dale McWilliams - E17HDB  
[dalemc@gmail.com](mailto:dalemc@gmail.com)

# British Inland Waterways on the Air



**The event is open to all Amateurs who are boaters, cyclists, walkers and other users of the canals, rivers, towpaths, riverbanks for work or recreation. Many clubs and individual Amateurs on or near the UK inland waterways obtain Special Event Station (SES) call signs.**

**Others operate mobile or portable using their call signs. Many more like to contact the BiWota stations. This was EI3CC first activation of the waterways on the air, we chose a stunning location Graiguenamanagh**

Graiguenamanagh is a beautiful town and is home to Duiske Abbey, originally a Cistercian Monastery, now a Catholic parish church. With a simple exterior contrasting with its elaborate interior, visitors can see the ancient stone and high clerestory windows of the nave as well as an effigy of a 13th-century knight at the entrance.

We set off from the usual location but had one advantage Wayne EI7HKB who lived not too far from the activation spot and was able to secure a good spot to park the RCU (Radio control unit) we needed to be on site early as there was to be a book festival and art competition too.

Our first task was to set up camp on the Carlow side of the river Barrow, great views and a lot of foot fall was to be expected.

There was an option of a sauna and afterwards a dip in the river but as expected that offer was declined.

A mast was clamped to a railing near the RCU and another clamped the length of our EFHW wire with a 49-1 which we hoped would work from this location which is in

a bit of a valley.

Radio's connected and SWR tested and all 100%, the south Dublin radio club were having there usual net on Sunday morning on 7.123 so I called in for a radio check and all seemed good in EI but alas we were the only waterway activation in EI so we hoped we would be good into the UK where most of the contacts could be made with other waterway groups.

We put out a few calls into the UK and our first contact back was into Yorkshire with a good 5-9+10 so we knew we had a good chance of working other waterway stations.

By 10am it started to get busy and the path alongside the river was full of passerby's and all curious as to what we were doing and how we were able to contact other like minded radio stations in the UK.



Calls into the station were building up and we were

# British Inland Waterways on the Air



filling the log fast, being the only EI station, we were proving to be very popular with the activators in the UK.

Meanwhile as the log was filling so was the art world who descended on the river with brushes and oil paints or even water colour, it was nice to watch them paint in between sessions on the microphone.



This was a one-day event for us. We normally have weekend outings so we have already got a site booked for 2026 which will be a weekend event.



The ICOM 7300 was working away with 100 watts on the end fed at about sixteen feet above the river.

One station that called in was from Oban in Scotland and that brought back many memories of working in Oban many years ago, so you never know what you will come across on the radio •



**John Tubritt- EI3HQB**

[ei3hqb@gmail.com](mailto:ei3hqb@gmail.com)

## First Contact Through the QO-100 Satellite Part II

The prospect of operating on satellites seems to be a daunting subject as some of the answers one receives are overly complicated. The use of the Low Earth orbital satellites requires a computer program to spot the time that the satellite will appear over the horizon for a specific location and time of day. Quite often the satellite pass is of a very short duration and quite possible to work using a dual 2m and 70cm Yagi antenna. Others use a combination of prediction program and software to automatically point the antenna at the satellite from the time it appears over the horizon to the time it passes over head and disappears again. It is not as complex as it seems. This article is intended to dispel the myths around operating above the 70cms ceiling and into the microwave regions. Better still the QO-100 satellite is geostationary and is accessible 24 hours a day. Once the antenna is aligned there is no need to go near it. If the bug is going to bite this is a good starting point. This may even bring you into the realm of microwave operation at a later stage.



- 
- 
- 
- 4) (Brown Cable)  
Short Lead from LNB to Transverter.(Black Cable)

### Additional items required

- 1) 2m Transceiver (ICOM-705) in my case
- 2) 90cm V Satellite Dish
- 3) Tripod
- 4) Power lead
- 5) PTT Line
- 6) Mini8 Coax from Driver to transverter
- 7) Straps to secure the SatRover to the LNB Feed Arm
- 8) Straps and pegs to add stability to the Tripod

The SatRover is a compact satellite ground station designed for rapid deployment for portable activity. It is easy to set up in the field and take apart quickly when finished. Sadly, the transverter unit is not waterproof but it can be installed in a small waterproof housing for a more permanent installation.

The Collective Communications Group (EI3CC) attendance at the Stradbally Steam Rally provided an excellent opportunity to set up my Sat Rover for the first time. Traditionally, EI3CC bring their Radio Control Unit (RCU) along kitted out with HF and VHF equipment and, in addition, run a Satellite system. Wayne, EI87HKB, owned a SatRover and was able to give good advice on the set-up of the system along with some nice hints and hacks on assembly and configuration. As a result, the system was assembled and on the air within a short period of time. A few addition parts were made available such as the straps to secure the SatRover to the LNB feed arm of the dish and some pegs and straps to stabilise the tripod. The tripod was stable, but the pegs and straps were more a precaution against a strong breeze. Given the surface area of a 90cm dish these were an asset.

**So firstly, the components received from the supplier Fig 1.**

- 1) LNB plus 5 turn helical Antenna for 2.4 GHz (Suited to standard Offset Satellite TV dish)
- 2) SatRover Transverter (Up converter 144 - 2400 Hz and Downconverter from 10 GHz to 144 MHz)
- 3) Short Lead from Transverter to 2.4 GHz Antenna

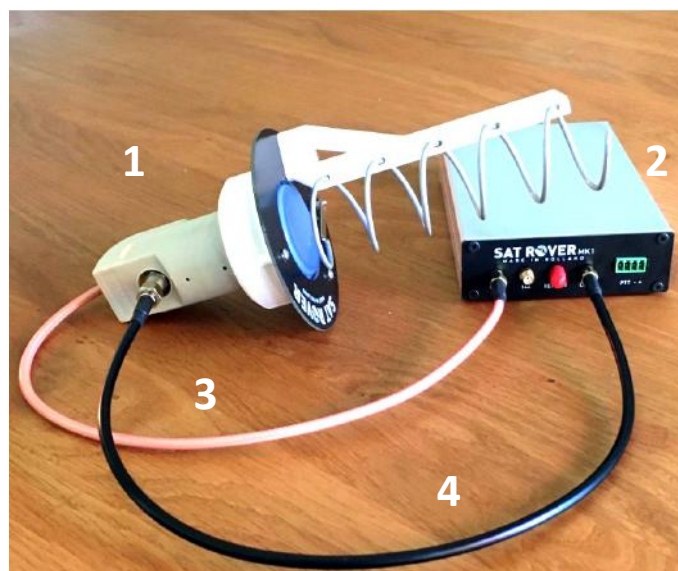

*Fig. 1 The Components of the SatRover Kit*

The SatRover contains all the TX and Receive components plus Frequency reference.

The Brown cable connects from the 2.4GHz TX to the helical antenna the second black cable connects from the LNB to transverter. The LNB is a standard TV LNB converted to accept an external reference close to 25 MHz.

I cut a 20 ft power lead, PTT lead and coax lead for the IC-705 to the Transverter box these were all

# First Contact Through the QO-100 Satellite Part II

terminated with Anderson Power Pole connectors in case a longer power lead and PTT was required. I have an additional 20 ft extension of power and PTT cable with power pole connectors.

Firstly, the Dish is assembled and mounted on the Tripod Fig. 2



Fig. 2 Assembling and mounting the Dish on the Tripod

The Sat Rover is mounted on the LNB feed arm with two straps Fig. 3

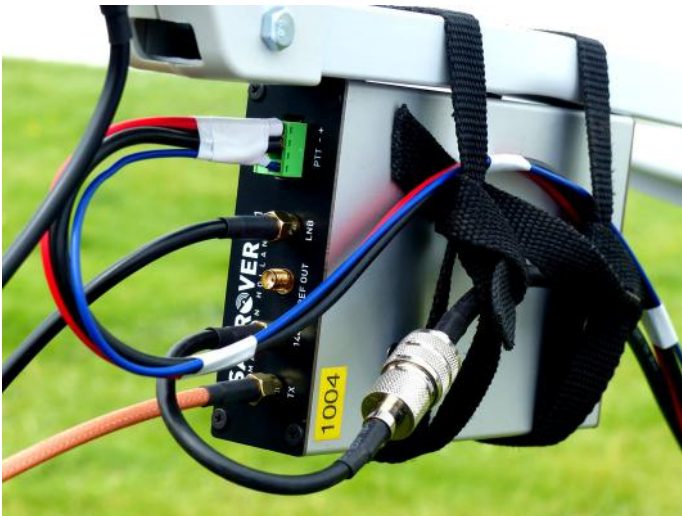

Fig.3 Sat Rover Mounted on the LNB Feed Arm

Having connected the transverter to the LNB and TX antenna, and mounted them on the support arm on the dish, it is necessary to align the dish to the satellite.

Ensure that the pole, on which the dish is mounted, is secure and stable as any breeze may blow the dish out of alignment.

The tripod was the type used to support disco speakers. Considering the wind capture area of the 90cm dish we decided to tie each foot of the tripod to aluminium pegs driven into the ground. Fig. 4. There was a slight breeze at the time and the weather was unpredictable.

An alternative to the tripod could be a pole mounted on a drive-on mast mount which can be obtained at most Rallies.



Fig.4 securing the feet of the tripod with pegs and straps

The next task is to orientate and align the dish to the Satellite.

The QO-100 Satellite is located over the centre of Africa at a height of some 35,786 Km and transmits linear polarisation. The LNB must be mounted in correct orientation. The orientation varies according to location on the earth's surface. This orientation is the skew angle.

An easy way to determine the direction and elevation and the skew of the antenna is to use a webpage <https://www.dishpointer.com/> Fig. 5

### Your Location

White Strand, Galway

Latitude: 53.3441° Longitude: -6.2673°

### Satellite Data

All Satellites | Motorized Systems | Multi-LNB Setups

25.8E ES'HAIL 2

### Dish Setup Data

Azimuth (true)	Azimuth (mag.)
142.0°	143.4°
Elevation	LNB Skew
22.4°	-21.6°

Fig 5 Location, Azimuth, Elevation and LNB Skew Data

Apply power and leave the unit to warm up for at least 5 minutes to allow the unit to stabilise.

Set the frequency of the lower beacon on the

# First Contact Through the QO-100 Satellite Part II

satellite and the mode to CW. Align the dish to the coordinates determined by Dishpointer. This may require a little fine tuning, but the signal will be evident. Coarse alignment can be achieved quickly. Fine adjustment can be made for optimum signal strength. **Fig.6.**



**Fig.6 Alignment of the Dish with Data from Dishpointer**

As polarisation of the 10 GHz signal is linear, it is necessary to adjust the skew of the LNB to compensate for our location with respect to the satellite. Slight rotation of the LNB is necessary and information is included with the data from Dishpointer site. This adjustment will optimise the received signal. This adjustment was not too precise as there seemed to be a reasonable leeway. I rotated the LNB to both left and right to find the angle of max signal strength. Looking at the back of the LNB pointing towards the dish the skew angle was approximately 21 degrees in a clockwise direction **Fig.7**



**Fig.7 Twist the LNB in a clockwise direction to achieve best signal strength - this should correspond to a skew angle of 21–22 deg**

There was a breeze blowing which moved the dish. It was necessary to move the dish back into alignment by listening to the beacon and moving the dish slightly left or right of its heading. It took very little time to realign whilst listening to the beacon,

Familiarise yourself with the band plan and ensure that you operate within the designated areas. The SSB section is coloured blue in **Fig.8**

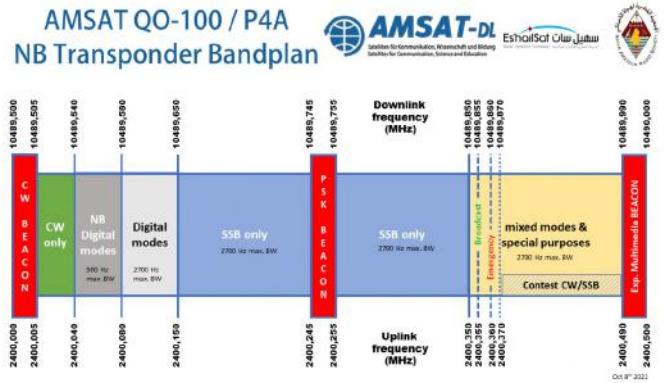

**Fig 8 QO-100 band plan SSB section is coloured blue**

Take a few minutes to listen around and get the feel of the band before plunging in headfirst. Observe the band plan **Fig.8** and adhere to it.

Next find a clear frequency in the SSB portion of the band plan e.g. between 144.650 and 144.745 corresponding to 2400.150 to 2400.245 or 144.755 to 144.850 corresponding to 2400.255 to 2400.350. Transmit a brief carrier and the transmission will display a line on the waterfall of the ICOM 705. On releasing the PTT a small dot will appear as a result of the brief reception of the downlink due to the delay of approximately 250ms. If this is offset from the line displayed by the transmit then use the RIT control to align it with the transmitted signal. At this point you will be listening on or very close to your transmit frequency. I was using the ICOM-705 to drive the SatRover with approximately 3.5 watts **Fig. 9**



**Fig. 9 Using the FT705 to drive the transverter**

Do not transmit excessive power into the satellite otherwise you will receive an audible warning. To check your input to the satellite, observe your signal received by

## First Contact Through the QO-100 Satellite Part II

the satellite using the QO-100 WebSDR available from <https://eshail.batc.org.uk/nb/> Fig. 10

Even if you have no equipment for QO-100 you can listen on the WebSDR.

Ensure that your signal does not exceed the level of the beacon signals by reducing the drive if necessary.

Put out a test transmission and tune into your signal on a separate receiver or use the QO-100 Web SDR. Note the frequency on which your signal is received. This may be slightly offset due to minor drift. Set your RIT to compensate for the offset. This will allow you to call a station on its transmit frequency if you are receiving it clearly. Generally, there will be little need to alter this setting when contacting other stations

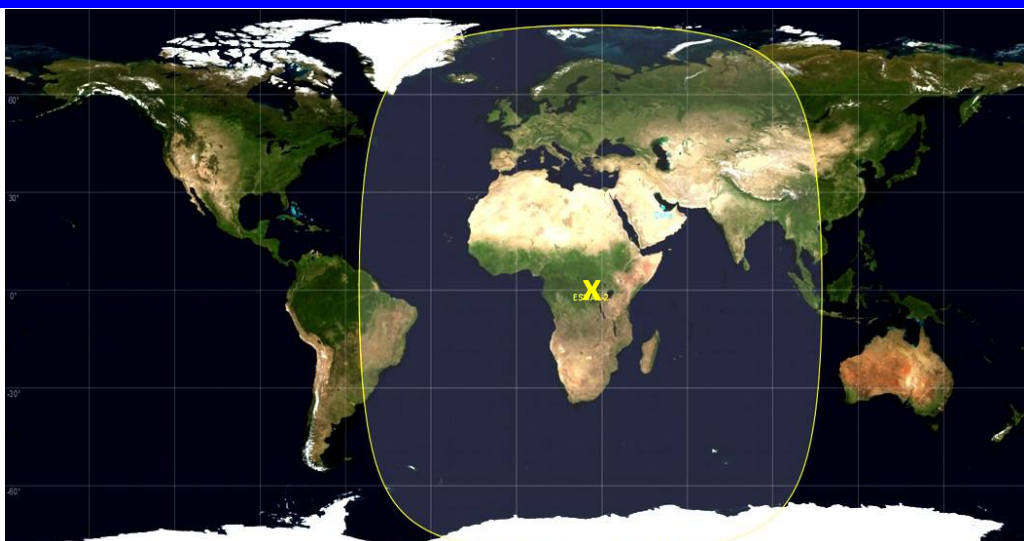

Fig.11 X marks the Position of the Satellite over the centre of Africa

price was not over the top and easy enough to sell on without a loss.

As it happens the SatRover is ideally suited to portable operation and the setup is not complex I would seriously consider something more permanent for the Home QTH following good experiences with my initial set up.

The SatRover cost around €600.00, the Dish around €50.00 and the tripod a further €12.00. It would be possible to mount the dish on a pole supported by a drive on mount. This was exceptionally good value in my opinion.

The DXPATROL, system is an alternative which offers a full duplex TX and RX and offers several different IF frequencies to drive either the TX and RX. This is very stable as it has a GPS locked internal reference. The power output is 10 Watts although one would probably never have to run it at full output. The cost is approximately €950.00 with postage extra. Further details from:

<https://dxpatrol.pt/produto/dxpatrol-full-duplex-qo-100-groundstation/>

The SatRover may be purchased from:

<http://www.hybridpretender.nl/>

Of course this does not preclude one from gathering the parts to build their own stations from scratch as there are many suppliers that stock the individual components to assemble ground station. Passion-Radio, a supplier within the EU, could be a good place to start: <https://www.passion-radio.com/satellite-qo-100/124> •

### Reference

[http://www.hybridpretender.nl/SatRoverMK1\\_UserManual.pdf](http://www.hybridpretender.nl/SatRoverMK1_UserManual.pdf)

Amsat UK <https://amsat-uk.org/satellites/geo/eshail-2/>

Amsat DL <https://amsat-dl.org/en/new-qo-100-band-plan/>

Steve Wright EI5DD

[wright14@gmail.com](mailto:wright14@gmail.com)

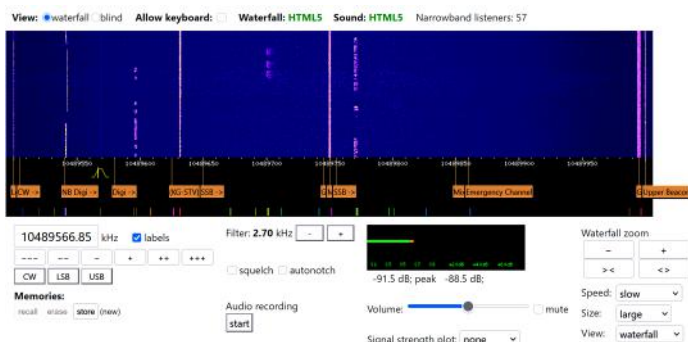

Fig. 10 The QO-100 WebSDR will show the entire band

If calling CQ and listening for any calls only tune the RIT to clarify and do not touch the VFO otherwise the station you are calling will be chasing you around the band. The initial part of the QSO would be an exchange of report and locator followed by an exchange of details and then you can take it from there.

As the satellite is geostationary, there is no time limit for your operation as it is available 24 hours a day. Stations within the footprint shown on the map Fig 11 will have no problem accessing the Satellite however stations located on the periphery of footprint would require more gain on both the TX and RX side.

Most of the signals are Strength 9 although those transmitting on the peripheral areas may be weaker. Those running less power or using smaller dish antennas with less gain would also be weaker.

As mentioned earlier the SatRover transverter is not waterproof. If it should start to rain all is not lost. Place a light plastic bag over the equipment mounted on the feed arm and secure it with a cable tie as a temporary solution. This had no adverse effects on the transmission and reception.

I purchased the SatRover as a reasonably priced entry to Satellite operation. If it did not impress me, the

## A Trip to the Newark HamFest 2025

I had often contemplated going to something slightly more than the average radio rally. Friedrichshafen was a possibility, but the thought of the journey into the unknown put me off. Something closer to home might stir the interest and then pave the way to a journey further afield.

The journey to the HamFest, located in Newark, involved a flight to East Midlands airport via Dublin. For me, this involved a bus journey from Galway at 1:45 am. This would have me in Terminal 2 in time for check-in and boarding the plane leaving at 6 am. The flight time was only 55 minutes and after fetching my case from the baggage re-claim I was on my way.

The journey continued with a bus from the terminal to Nottingham Railway Station and then a train to Newark Castle. Not having a clue where the Rally was located, I chose to take a taxi to the showground. It was too early to check into the Premier Inn, so I had to drag my suitcase around with me for the day. This proved to be a good idea as I did not have to lug around goodies under the arm.

The Show ground is a huge area and has an aviation museum situated in a large hanger close by and I gather that the area is often used for Rock Concerts. As I had booked my ticket beforehand, I got an armband at the gate and was admitted immediately. There were many cars already in the car park so the crowd was building.

The flea market was visible in the distance along with a huge mast from the Camb Hams who were operating



the Special Event Station GB25NH. The flea market had some interesting bits and pieces including second-hand transceivers and treasure for reasonable prices. I was not really in the market for second hand kit on this occasion as I had my sight set on specific items.

On walking through the door of the main hall, the expanse was huge inside the hangar. Where does one start? A bit like the Woolworth's sweet counter! – so much



# A Trip to the Newark HamFest 2025

choice! The RSGB stand was straight in front with a huge selection of books. There were many other booths allocated to the RSGB for Propagation Studies, the Buildathon, and membership to name a few.

Many other clubs and special interest groups were present in the form of RFARS, BOTA, BLYLARA, WAB, CDXC, BOTA, BATC, RAYNET, Radio Fraternity Lodge 8040, and VMARS. They could keep you chatting all day!

I had been one of the first few to enter but the crowd was not long building up but despite the huge number, there was plenty of room between exhibits to walk around.

ICOM were displaying their products, and this



included the new ICOM IC-7300 MkII which was under a Perspex cover. The new ID-52 and ID-5200 were also on display amongst their other popular models.



Kanga kits were present with a large range of projects/kits and pre-built items. Something for the winter months! As I had mentioned, earlier there were plenty of stands selling components and it was worth checking them for some of the rarer items.

The YAESU stand was situated at one end



of the hall taking up a full corner with their products which included their recent additions and old favourites. The FTX-1 was of particular interest which is essentially a 10W transceiver which can have a Power amplifier module attached for base station operation. Novel, but expensive!

Other prominent exhibitors were BHI with their noise cancelling products, SDR Play,

# A Trip to the Newark HamFest 2025



Peak Electronics, Telonic RIGOL, LAMCO, Moonraker, and Canny Components. There was a wealth of components available from GS electronics and Canny components Rich Electronics.

The catering area was behind M L & S. It was almost impossible to get a look in as the crowds queueing for a brew was huge. I had to stand for ages before getting my bacon butty and a cup of tea. It was worth waiting for as I could have eaten a scabby baby at this point! Refreshed, I decided to take a last trip around the stands. I bought the handful of plugs and sockets that one always does as rallies. I checked around the other stands for goodies but had to reign back. I did not need extra weight or anything else.

Martin Lynch had an impressive display of

equipment and everything was at hand. Rigs and ancillary equipment galore. Antennas, test equipment, second hand kit and accessories. Martin was chatting to everyone and a good team from the shop were at hand to offer assistance or advice and of course to sell the wares. There was no rush and everyone was given the time of day even if it was just an enquiry about an item on the stand.

I had come with the intention of purchasing a good antenna analyser and settled for the RigExpert Match which had all the facilities that I wished for. It worked up to 500MHz which was more than enough for my requirements. Once one goes past 500 MHz the price increases exponentially! Whilst enroute I had toyed with the idea of purchasing an ICOM-705 as a driver for the satellite gear and SHF transverters. On purchasing, I was given a receipt to take to the ICOM stand where I received a free LC-192 backpack worth over £120.00 and a 5 year warranty for the ICOM 705. I was delighted with my purchases from M L & S.

As the time approached 4pm it was time to depart after a quick scoot around the stands in case there was something I missed. I took a taxi back to the hotel, booked in and had a good rest before I went for dinner.

The Hotel had a reasonably inviting menu and I enjoyed the meal. By this time many of the traders were already established in the restaurant. Following the meal, I went back to the room and read through a couple of books I had purchased from the RSGB stand before dozing off.

The following day it was an early start at 8 am breakfast, checkout and a taxi to the station. From Nottingham it was a bus journey to the airport. East Midlands airport was not the best as it seemed to be a little disorganised and casual at the check-in desk. The Ryanair flight was quickly boarded, and the journey back home was not delayed. Probably the worst part is the journey from Dublin to Galway on the bus.

I will travel there next year as I met many friends and people who were full of praise for Ham Radio Ireland Magazine and the activities of EI3CC •

*Steve Wright - E1SDD*

[wright14@gmail.com](mailto:wright14@gmail.com)

# The Fleamarket at Newark 2025 HamFest

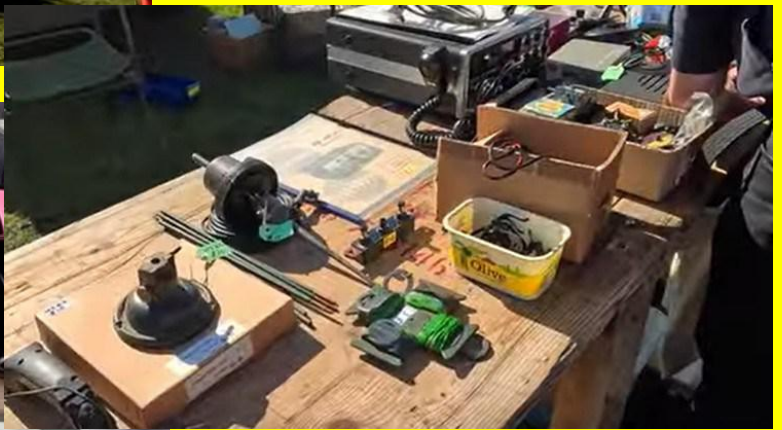

# Guerilla Marketing Amateur Radio with Google Maps

**M**ention the subject of promoting the hobby, and many Amateurs shrink away in horror at the thought of talking to non-Amateurs about our weird and wonderful hobby.

But there's a simple way to tempt newcomers into the hobby without ever having awkward conversations. All you have to do is:

- Get out of the shack and play radios out in the big wide world
- Take pictures of your field operations
- Put those photos onto Google Maps, with a simple review like "this is a great place to play Amateur Radio!"

The idea came to me recently, when members of my club, the Manly-Warringah Radio Society, set off for their annual pilgrimage to the Victorian High Country to camp and of course get on the air and make loads of contacts. The trip is documented on the club blog.

I looked it up on Google Maps. Having found it, I read the reviews of the area.

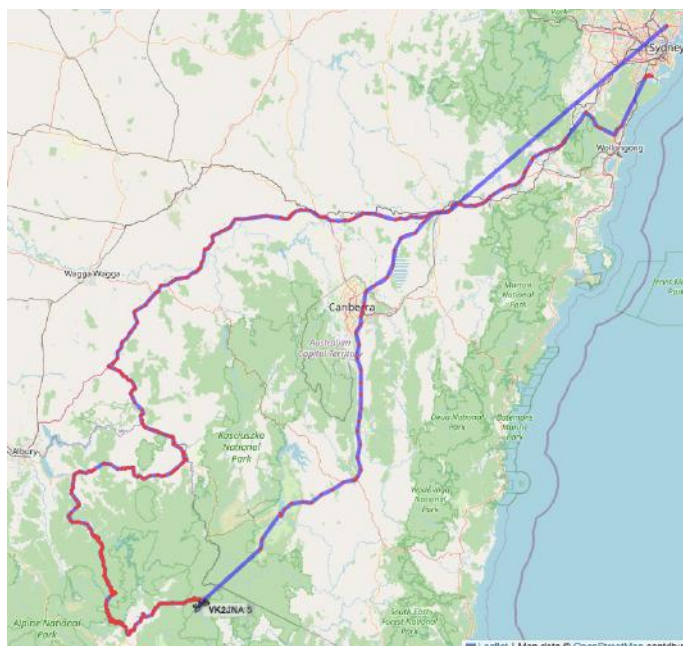

There were none, so I added one: "Great place in the Victorian High Country for playing Amateur Radio (Dom VK2JNA pictured doing just that! You can read about it at...)" with a link to the club blog post. It took all of about two minutes to do that.



One of the photos that the guys took struck as particularly noteworthy, as it told the story: an Amateur (Dom VK2JNA) playing radio in a great location, Rams Horn at Cobberas, Victoria

My next thought was, "where exactly is that?"



More recently, I did the same for the club operating portable in the Watagans for the 2025 John Moyle Field Day. Again, it took only a few minutes to do.

Step-by-step, here's how to do it:

- ◆ Go operate portable - I'm sure you don't need me to tell you how to do that! It doesn't have to be an exotic location: even a local park works fine. While you're there, take photos of yourself enjoying playing radios. See Promoting ham radio while promoting your club in Amateur Radio magazine, vol 91 no. 4 for photo and other PR tips.
- ◆ In your web browser, go to Google Maps and find where you were operating. There, or somewhere nearby, you should see a named location. You might need to zoom in for the location label. Click on the

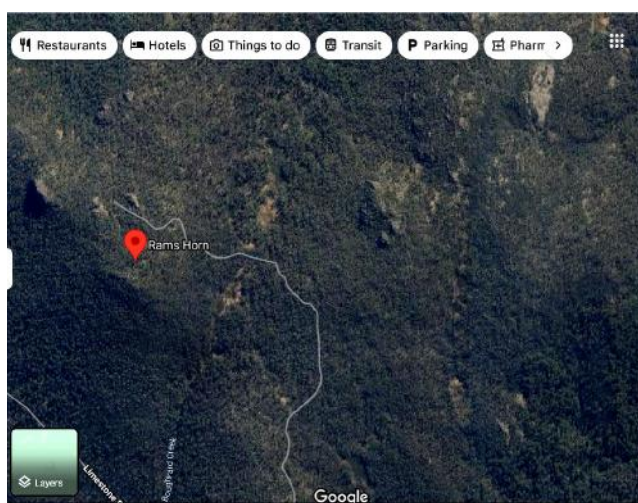

# Guerilla Marketing Amateur Radio with Google Maps

label to show more information about the place; it will appear on the left side of the screen.

- ◆ Click on Reviews, then click on Write a review.
- ◆ Click on the rightmost star (you had fun there, so it's worth five stars, right?)
- ◆ Below the stars is a box with the instruction, Share details of your own experience at this place. Your review can be very simple, like "this is a great place to play Amateur Radio!". If you have done a blog post about your time there, you can include the URL too. This will help drive visitors to your club web site.
- ◆ Click on the Add photos and videos button and add your photos and video. Click on the X button to close that window.
- ◆ Finally, click the Post button, and your review will be added to Google Maps. Easy!

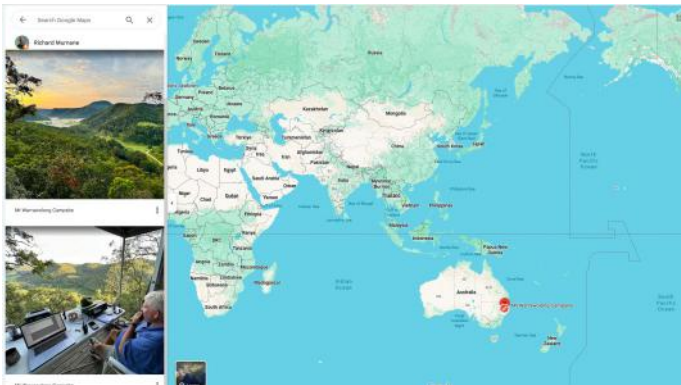

- ◆ Now, will this lead to an influx of new Amateurs? No, my two photos alone won't do it, but if more of us went portable to fun locations, took good photos, and included them in reviews of the locations we visit, then more people would learn that our hobby is still alive and well, and maybe tempt them to give it a try!

Since I started writing this article, I have gone through some older photos and begun posting more reviews, for example, at the historic Barrenjoey Lighthouse in northern Sydney, the HF comms room on board the Royal Australian Navy destroyer HMAS Vampire (where I sometimes volunteer) near the city centre, and other locations.

Any place that people visit, and that Google Maps thinks is worth labelling, can work here. The key with the photos is to have three key elements: people, radio, and the location, like the examples here. You can also include a link to your club web page too, and come back later to update your review with better text or photos. As I mentioned earlier, local parks and recreational areas work great too: even better because passers-by notice what we're doing and express curiosity and interest.

It helps to have short flyer explaining how fun it is to "play radio". It's happened to me so often that I had business cards printed for my club, so that all our members can carry a few in their wallets or purses. They're inexpensive, and the cards include a "QR code", so that anyone can scan it and jump straight to a welcome page on

our club web site. Since we started doing this, the club has experienced a significant jump in membership: having a hand-out or business card is much more effective than saying "just Google it".



Each Google Maps review has the potential to raise the public profile of Amateur Radio and draw new blood into the hobby. And if nothing else, you'll have a great time operating portable!

Links (I'll leave you to use your favourite link shortener):

Pilgrimage to the Victorian High Country:

<https://www.mwrs.org.au/2024/12/29/pilgrimage-to-the-victorian-high-country/>

Google Maps review of Rams Horn, VHC:

[https://www.google.com/maps/place/Rams+Horn/@-36.9036879,148.1230202,15z/data=!3m1!4b1!4m6!3m5!1s0x6b24bba18f4060b5:0x3cef9c2de9e1b834!8m2!3d-36.9036885!4d148.1230202!16s%2Fg%2F11j1d2dr5d?hl=en&entry=tту&\\_ep=EgoyMDI1MDgwNS4wIjKXMDSoASAFQAw%3D%3D](https://www.google.com/maps/place/Rams+Horn/@-36.9036879,148.1230202,15z/data=!3m1!4b1!4m6!3m5!1s0x6b24bba18f4060b5:0x3cef9c2de9e1b834!8m2!3d-36.9036885!4d148.1230202!16s%2Fg%2F11j1d2dr5d?hl=en&entry=tту&_ep=EgoyMDI1MDgwNS4wIjKXMDSoASAFQAw%3D%3D)

2025 John Moyle Field Day ops near Mt Warrawolong Campsite in the Watagans:

[https://www.google.com/maps/contrib/110556003390127000434/place/ChIJMcJXKgDVGsRJJ-5BEkgQUE/@8.2787663,72.5309422,3z/data=!4m6!1m5!8m4!1e1!2s110556003390127000434!3m1!1e1?hl=en-AU&entry=tту&\\_ep=EgoyMDI1MDgwNS4wIjKXMDSoASAFQAw%3D%3D](https://www.google.com/maps/contrib/110556003390127000434/place/ChIJMcJXKgDVGsRJJ-5BEkgQUE/@8.2787663,72.5309422,3z/data=!4m6!1m5!8m4!1e1!2s110556003390127000434!3m1!1e1?hl=en-AU&entry=tту&_ep=EgoyMDI1MDgwNS4wIjKXMDSoASAFQAw%3D%3D) •

Richard Murnane VK2SKY

[vk2sky@wia.org.au](mailto:vk2sky@wia.org.au)

# Stradbally Vintage Steam Rally

**F**ounded in 1964, the Irish Steam Preservation Society is dedicated to preserving and showcasing Ireland's steam-powered history. From hosting Ireland's longest running steam rally to operating the only narrow-gauge steam train in the country, we work tirelessly to ensure future generations can experience the magic of steam.

We arrived on site on Friday afternoon this allowing us to set out our pitch. As we were the third display in, we would have a large footfall. We brought our RCU (radio control unit) two gazebos and three tables and behind those we had our Q-100 satellite setup and parking for our vehicles.

Setting up took only an hour or so and we had a plan of what we would display over the weekend to attract the crowds.



*Aerial view of the Stradbally Steam Rally*

while some earned a HAREC Cert to operate ham radios, others remained on CB bands to continue chatting with friends.



*RCU and Gazebo set up ready for display*

Once set up we could relax over a cup of tea and even consider what we would do for our evening meal; whether a takeaway or something in the oven in our group caravan.

Over the weekend, members will call in and some may camp on site, making it a lively event with opportunities to see vintage steam arrivals and socialize.

On Saturday, this event is usually very crowded. As this was the 61st rally, and well established, it attracted a large following as can be seen from the following image our setup is only a pin prick in the grounds of Stradbally Hall. The aim for the weekend was to introduce the hobby to individuals of all ages.

We had people who called over to us who, many moons ago, may have had a CB radio and would reminisce on the days of working stations all over the world, and when confronted with our Ham radio equipment they were intrigued with the stations they heard in the RCU from the thin wire (EFHW) or even the QO-100 satellite system.

Ireland, like other countries, had many CB users;



*Wayne demonstrating our basic electronics kits*

# Stradbally Vintage Steam Rally



**Working Traction Engines on display at the Stradbally Steam Rally**

We are very visual having the RCU and we also display our EI3CC flags on the ground and on poles This makes us visible even if you are away from the stand and it is also a good eye catcher. We also have a medieval stock, and this is a sure way to get people over to your tables as curiosity is a human trait.

Once they peruse our display, they ask about the stocks to which we explain that you can put people in it but we have a trick to getting them out. So, an example as follows - Billy arrives with his dad and asks about the device and after some explanation of its purpose his father is clamped into it. But, for Billy to get his father released, now must send his name in CW and his father will be set free.



**The ever popular Mediaeval Stocks**

We offer versatile kits that can be set up as a buzzer, spinning fan, or flashing light bulb, keeping kids engaged at the table and allowing them to use CW keys for sending SOS signals.

Steve, EI5DD, brought along his newly acquired SatRover gear and Wayne EI7HKB helped with the setup and tuning allowing Steve to work for the first time on the QO-100 sat system.

The main event is steam and we are privileged to have some of the finest equipment in the country, one tradition on Saturday evening is the parade in the village whereby some of the vehicles leave the grounds of Stradbally hall and head for the village later to return via the local village.



**EI5DD's QO-100 SatRover first time out**

Our RCU has its own solar power for radio use, and all cooking gear is stowed onboard, so we are always prepared to cook at rallies if needed.

And so our vintage outing for 2025 comes to an end another great success in spreading the word of our great hobby lots of info given out on how to get a license



**A good hearty Breakfast to start the day**

and who knows maybe I will be having a QSO with someone who came to us at Stradbally vintage rally.

If you want to view more of this event please visit out YouTube channel:

<https://www.youtube.com/@CollectiveCommunicationEI3CC>

Please like and subscribe for further video's •

**John Tubritt- EI3HQB**

[ei3hqb@gmail.com](mailto:ei3hqb@gmail.com)

# Antenna Masts and Planning Permission in Ireland

For many of us involved in radio, whether as licensed amateurs, shortwave listeners, or simply homeowners wanting reliable TV reception, antennas and masts are part of daily life. But before you put up a new mast, antenna or dish, there's a critical step that can't be ignored: **Planning Permission**.

In Ireland, antennas and masts fall under the Planning and Development Acts 2000–2023 and the Planning and Development Regulations 2001 (as amended). Some small installations are exempt, but others require formal planning approval. Failure to comply could result in enforcement action, fines, or even having to remove your equipment.



## Support from Amateur Radio Bodies in Ireland

Unfortunately, many radio amateurs in Ireland have found there has been little to no guidance from the main amateur radio bodies when it comes to planning permission issues. When asked for advice, the response is often simply to 'say nothing and keep quiet'. This lack of proactive support leaves individuals to navigate the complex planning system on their own. Rather than providing clarity or championing members' needs, these organisations too often prefer to keep their heads in the sand.



## Antennas on Houses – What's Allowed Without Permission

Under Schedule 2, Part 1, Class 4, certain household antennas are classed as exempted development. These include:

### TV and Radio Aerials

- Permitted on the roof of a house.
- The highest point must not exceed 6 metres above the roofline.
- Exceeding 6 m → Planning permission required.

### Satellite Dishes

One dish per house is exempt if:

- It is 1 metre or less in diameter.
- Positioned at the rear or side of the house.
- Not higher than the highest part of the roof.
- Not on the front wall or front roof slope.

## Multiple Antennas or Large Dishes

- Additional dishes or larger antennas require permission.(on your house)

## Protected Structures & ACAs

- If your home is a protected structure or in an Architectural Conservation Area (ACA), no exemptions apply – you must apply for planning permission, even for small aerials.

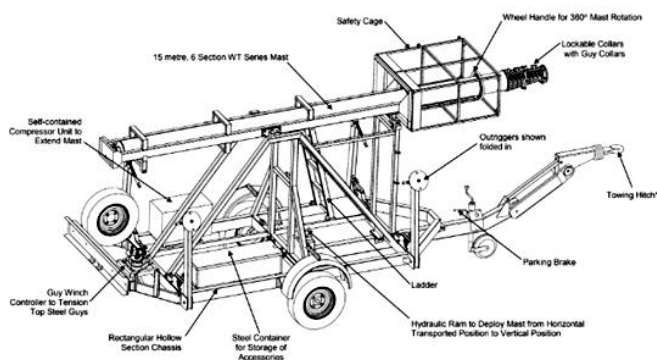

## Free-Standing Masts and Towers

Free-standing mobile masts and towers in a garden are not exempted development and almost always require planning permission. Councils assess them as new structures, with decisions based on:

- Visual impact on neighbours and the streetscape.
- Height and design of the mast.
- Safety concerns (guy wires, collapse risk).
- Noise issues (wind resonance, vibration).

## Section 5 Declaration – The Smart First Step

the first step

If you're unsure whether your antenna or mast needs permission, you can apply for a Section 5 declaration from your local planning authority.

# Antenna Masts and Planning Permission in Ireland

- Cost: Around €80.
- Submit: Drawings, photos, and dimensions.
- Decision: Within about 4 weeks. If you disagree, you can appeal to An Bord Pleanála. This is the safest way to get clarity before you buy or install equipment.

## The 7-Year Rule – A Legal Loophole?

Ireland's planning system includes what's known as the 7-year rule:

If a mast or antenna has been in place for more than 7 years, the council can no longer enforce against it. BUT – it still remains unauthorised.

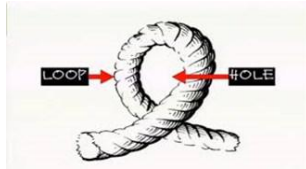

You cannot apply for retention planning permission after 7 years, since there's no enforcement risk left.

This may cause legal issues when selling your property or dealing with banks/mortgages.

**Tip:** If your mast has been up for over 7 years, consider applying for a Certificate of Lawful Development to confirm its legal immunity.

## What Happens if You Don't Comply?

- Within 7 years: The council can issue an enforcement notice, requiring removal or imposing fines.
- After 7 years: The mast remains unauthorised, but cannot be enforced against.
- **Worst case:** Court action, removal of equipment, and reputational harm.

## Tips for Radio Amateurs and Homeowners

- Stay within the 6 m rule for rooftop aerials.
- Limit yourself to one  $\leq 1$  m dish at the rear/side.
- Always check if your property is a protected structure/ACA.
- For free-standing masts, assume planning is required.
- Apply for a Section 5 declaration before spending money.
- Keep your neighbours informed – most objections arise from lack of communication.
- Remember: a ComReg radio licence allows radio operation, not physical structures.

## Conclusion

Antennas and masts are essential for modern communications, from TV reception to amateur radio. But in Ireland, they are also subject to strict planning rules. Understanding these rules, and using tools like the Section 5 process, will help you stay compliant, avoid enforcement action, and enjoy your hobby without hassle.

Whether you're putting up a simple TV aerial or planning a full amateur radio tower, take the time to do it right. In the long run, it saves money, stress, and potential legal problems.

**N.B.** information correct going to print. Always contact your local council on planning matters, as there may slight differences from council to council •

Lez Ferguson EI4GEB

<https://www.qrz.com/db/EI4GEB>



DISCOVER

FREEMASONRY

Integrity • Friendship • Respect • Service

*We are a unique members' organisation that has thrived for over 300 years.*

*Having no political or religious affiliations, we comprise members of all ages, races, religions, cultures and backgrounds.*



Radio Fraternity Lodge  
No. 8040

Email: [radiofraternitysecretary@gmail.com](mailto:radiofraternitysecretary@gmail.com)



**BUSHVALLEY  
AMATEUR RADIO CLUB  
ANNUAL RADIO RALLY**

Bushvalley Amateur Club are pleased to announce that this year their annual rally will be on Sunday 2nd November at the usual venue, Limavady United Football Club, Rathmore Road, Limavady, BT49 0DF. Several traders will be in attendance along with a Bring and Buy stand.

Car parking available on site and on the Rathmore Road.

Our usual on-site catering will be available

Doors open at 11:00

WE LOOK FORWARD TO SEEING YOU THERE!



SCAN ME

[bushvalleyarc@gmail.com](mailto:bushvalleyarc@gmail.com) [bushvalleyarc.org](http://bushvalleyarc.org)

# International Lighthouse Weekend

The international lighthouse weekend is upon us again, We love this event as we have a stunning location for the activation. We are at the lovely Balinacourty lighthouse Dungarvan and our host Johnny who resides in the lighthouse cottage always welcomes us with open arms, this now being our third year at this particular spot.

The light at Ballinacourty was first established on 1st July 1858. The light was converted to acetylene operation in 1929. Electrification of the light took place on 12th February 1964. The present light source comprises a cluster of 4 x 35W halogen lamps and was installed during the 2005-06 re-equip of the station.

We arrived at the lighthouse on Friday midday allowing us to set up the station at a leisurely pace as the lighthouse weekend only gets going on Saturday.

As always, we bring along our RCU (radio control unit) and caravan. Having the RCU enables us to set up fairly quick as all equipment is self-contained in the unit and in no time, we have the basic camp set up and as we are expecting a number of visitors over the weekend, we have plenty of room to rearrange if needed.



The town of Dungarvan is only ten minutes away from the lighthouse and after the camp was basically set up and Steve EI5DD had arrived from Galway we decided we would go and have a meal out and enjoy the evening sunset.



The weather for the weekend was looking good and we were going to need the sunblock to prevent the farmers tan as we call it. In the past, we had to deal with the after effects of a storm but we are lucky that the boundary wall gives us some protection. The QO-100 equipment was set up in the event the bands on HF may not be playing ball and at least we could get some radio done over the weekend.



We returned to the lighthouse and got the radio equipment up and running and made a few contacts for test purposes and to see how the bands would be working as Steve EI5DD was looking forward to operating 40M as he has difficulty at his home QTH getting a good antenna in his small back garden.

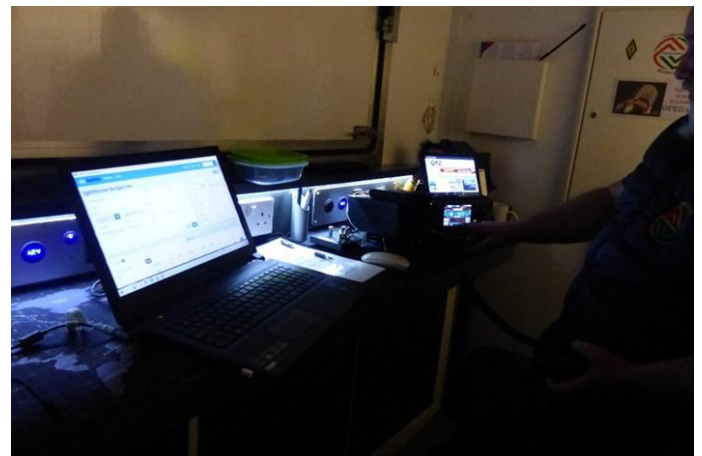

The RCU is totally independent with having a full

# International Lighthouse Weekend

solar system and onboard batteries it also converts into a sleeping unit as the bench slides out into a bed, In addition. it has its own cooking facilities; so in the event of wanting a coffee in the night the facilities are close at hand.

We can run 3-4 radio's at any time as we have 3 radio panels with separate antenna links and power sources.

Saturday morning was a stunner with the sunrise giving a great boost to the team for the day ahead, We had arranged with one of our group members, Frank EI8JLB who lives locally, to pick up the breakfast rolls on the way in so at least we had no cooking to worry about.

Steve, EI5DD, got straight into the Lighthouse mode and he was logging contacts as quick as he could type them into the lappy (we were running HAMRS logging). Steve had brought his headset and foot switch which was compatible with the ICOM 7300.



Steve and Wayne The log filled quite fast and Steve was in his element on 40m.

Philip had also arrived and the camp was buzzing with radio from the RCU, antenna building, and great banter under the canopy out of the soaring sun.

Johnny left the lighthouse open for us to view so I took the opportunity to wonder up with the camera and I was surprised how small the bulbs were and how much the lenses increase the light ten fold.



Elsewhere Wayne, EI7HKB, was helping Frank with an issue he was having with his POTA gear this later turned out to be a faulty bought patch lead they then preceded to build one of Wayne's 49:1 antenna's for Frank's QTH.



Alex, EI1895, had brought a Discone antenna and assembled to connect to his scanner and listen to the marine bands as we are on a shipping lane to Cork harbour.

Dale, EI7HDB, arrived and intended to stay overnight. He shared the operating throughout the day with

On Saturday evening, another trip to Dungarvan this time to the Curry House for refuelling food. After an excellent meal, it back at the lighthouse. Wayne gave a demo to Frank on the use of chirp to reprogram his handheld. Steve and Dale had returned to 40m in the RCU to continue logging lighthouse stations.

That brought Saturday evening to an end a lot of tired heads after a great day of radio and construction and best of all a great laugh in great company.

Sunday saw a great sunrise and a great breakfast Dale EI7HDB on the cooking. He did a great job! We worked more stations 200 in all with 43 of those lighthouse activations. We decided to break camp at midday as the wind had picked up and it had gone overcast.

We had a great weekend and we had a visit from our local heroes, the Coastguard Helicopter, patrolling the coast to finish our lighthouse weekend 2025 off in style •

**John Tubritt- EI3HQB**

[ei3hqb@gmail.com](mailto:ei3hqb@gmail.com)

## HamCation 2025

Last year I visited the Friedrichshafen 'Ham Radio' event for the first time. One of the stands was all about publicity for the HamCation radio rally in Orlando, Florida, USA. I had a good chat about this with the husband-and-wife team and put the 2025 dates into my diary (February 7-9 2025). It was suggested that this rally is the second largest in the World, behind Tokyo. Debateable, I guess, but it did turn out to be pretty large.



I did not have a travel buddy for this trip and my YL was not interested so it would have to be a solo trip. Flights were booked with Aer Lingus, Dublin to Orlando, and the Rosen Inn at Pointe Orlando was booked (one of the discounted local hotels - \$80.00 a night plus taxes). Flight availability dictated the duration of the trip and I booked a week, Tuesday to Tuesday. I wanted a bit of sightseeing whilst there.

The journey there was long and involved a lift to the



coach stop, coach to airport, flight, then Uber taxi to the hotel – 17 hours door-to-door. It took a few days to recover; another advantage of arriving a little early.

The HamCation event itself is held at the Central Florida Fairgrounds and Expo Park, which was a thirty-minute car drive from my hotel. By this time, I had met two German amateurs who were there to represent the DARC stand. Both had good English and one had a hire car so we travelled together each day.

The event was open 9-5p.m. Friday and Saturday and 9-1p.m. Sunday.

On arrival, the first thing I noted was the very long queues! However, this turned out to be for those buying tickets on the day. I had prebooked (and just missed the early bird discount so paid \$25 instead of \$20). I collected my ticket from a hut referred to as 'Will Call'. I then entered the main hall which housed the vendors – all the big names plus more, and specialist stands. Quite a lot to see and get round.

There was a second smaller hall (but still very big) displaying the sign 'Swaps', and this was the indoor flea market. There were also many outdoor 'boot sale' vendors selling used items from their vehicle, often a very large RV!



There was a third hall and this was primarily associated with the prize draws. These were hourly as well as a grand prize draw at the end of the event. This was an IC-905 and all of the accessories that went with it. Very nice.

Each day there was a programme of presentations held in air-conditioned tents. Forty-two in total. The

# HamCation 2025

presentations I attended were:

- Receiver and Transmitter Performance. What has changed in 10 years. Rob Sherwood. NCOB.
- VHF and Up Operating in Florida. Florida Weak Signal Society. Basic Concepts of HF Antennas. Bob Lewis. N8GU.
- DX Marathon. The Fastest Growing DX Program Today. Mark Wohlschlegel. WC3W.

There was also an outside food area with a good number of stalls. With two-and-a-half days at the event, I probably managed to get round about three times.



The webpage for HamCation advertised an associated event on the Friday evening - The Florida Contest Group dinner. I bought a ticket for this in advance. An interesting evening with drink, food, raffle prizes (Top prize an IC-7610) and a guest speaker - Jeff Steinman, N5TJ.

Following the event, I had a couple of days for further exploring. Orlando is basically all about Disney World and family holidays. Every evening you will see people dressed up as Disney characters and the like. On the last evening, I bumped into Darth Vader!



All in all, an interesting event and worth the overall cost and effort. Would I go again? Yes, but as I have not yet been to Dayton or Visalia and some other large events, it's probably unlikely •



It was also interesting to chat with people. The vast majority were American. I also heard a lot of Spanish being spoken.

Roger Greengrass EI8KN

[ei8kn.ie@gmail.com](mailto:ei8kn.ie@gmail.com)

# IRTS HamFest 2025

The IRTS recently decided to run a HamFest of its own in Ireland, we currently have three radio rallies' early in the year so it was deemed that perhaps an event in Autumn may be an option in bringing the season to a close. We at EI3CC were invited to the event by the new president John EI4L and Andy EI7IOB, we accepted and we made plans for the trip. The event was to be held in Mullingar Show Ground so for us it would be a 440km round trip so the last thing we needed was to forget something vital.



weekend.

Straight away we got into setting up our RCU (radio control unit) the weather was going to be an issue for the weekend as a storm was going to pass us by Saturday night Sunday morning. So, some of the setting up was done in between showers but in no time we were live.

As is the norm with us for activations we head off on a Friday and arrive on site mid-day and have a station set up ready for Saturday morning but, in this case, we were unable to get access to the site until Saturday morning so with this being the situation, we decided we would travel up to Mullingar on Friday and stop in a truck stop overnight and at least only have a short distance to travel to the event on Saturday morning.



Our first stop was in service station in Portlaoise, advice was then gained from some of the truck drivers as to a stopover location as near as possible to the showgrounds where the HamFest would take place, we were told of a site in Kilbeggan thirty mins from our destination but we needed to ask permission to park or face clamping.

This stop over was brilliant great food and open 24hrs, the following morning we had coffee and breakfast and we were on the road again and in no time, we had arrived at the Mullingar showground. We were greeted by Andy EI7IOB and shown to our designated spot for the



The next job on our list was to erect our flag, as a group we are known for flying the flag for our hobby so with this event planned I acquired a new flag just for the occasion this flag was 2,4mtrs x 1,5mtrs and it was to be mounted on our newly acquired telescopic mast courtesy of Steve EI5DD.



# IRTS HamFest 2025

The event was to go live at 12 noon so it was not long before other clubs and groups had started to arrive and start setting up their own stands most of these being indoors, it was great to see the enthusiasm.

from it in 2015 was convinced it had been scrapped based on the condition he last seen it.

One young man called to look at the station with his handheld in his hand and saying he can't wait to get his licence and be able to talk on the radio and with that Wayne EI7HKB informed him while in the company of a licenced operator he could work a radio and in no time, he was working the HamFest station in the UK so a HamFest to HamFest contact was his first ever logged contact and he was over the moon and went on to work a few other stations and that made his weekend special.

While we were busy so was the club displays in the



The EI-DX were busy getting a Hex beam up as this weekend would also be the SSB Field day so hopefully many operators who were not attending the event could work the station.

RAYNET had arrived from over the border and had a display indoors but also had an emergency telephone system working on mesh and EI3CC was asked if we house



one of these antenna and phone in the RCU so a link could be set up internally and externally for demo purposes.

Other clubs had set up in various fields around us as it was a contest weekend, they wanted to make the most of the weekend getting calls logged, Dennis EI4KH from the Patriot radio club was working from the club caravan. And the Shannon basin club had a big station in the lower field too.

Time passed quickly and it was noon and gates open and in no time EI3CC RCU was getting very busy as many people had come to look at our setup and inspect the RCU, one individual who worked a station



other buildings with various displays, Tony EI5EM a well-known home brew operator had been usual display of equipment on show.

The Galway radio club was displaying the Morserino CW kit and beside them a spark CW generator was also in action



# IRTS HamFest 2025

The rest of Saturday seen us flat out with visitors to many of whom had seen the RCU on its travels around the country but wanted to see it in real life. Lots of ideas were taken away on the construction and we may in the future see some of these in other RCU's.



The day was drawing in and we were still inundated with visitors late into the evening some great discussions on the group and what we had achieved in our three years as a group, this particular weekend being more poignant as it was our third birthday sadly the weather scuppered any chance of the proposed birthday BBQ.



The last of the visitors left at 22.00 and we could get some sleep after a long day.

Sunday morning was to be an early start after a stormy night, the RCU has sleeping area and with the winds in the evening it was looking like it would take off others in the tents did well to stay in the same field too.



Our caterers on site were brilliant with great food and free tea and coffee in the evening they did fantastic pizza, we had a chat with them on Saturday evening and they agreed to come back in the morning (Sunday) and dish up lovely breakfast sandwiches so well done to the catering team`.



After a fine breakfast, we set up the RCU this time we had our QO-100 station also running this was again to gather great interest as many had heard of it but not seen it up and running and our setup was the easiest way of having a QO-100 station.



# IRTS HamFest 2025



We would be using the Satrover mounted on the dish and the good old FT290R radio for TX, John the President of the IRTS was interested in checking out the setup and was duly invited to the RCU where Wayne EI7HKB and John EI4L spent a good while running the QO-100.

Sunday was also to be the car boot day and lots of radio operators had turned up with all sorts of items of interest and perhaps purchase. Ray from Long Communication had also made the trip with hi usual line up of much needed items and antennae for the QTH,

Behind the RCU, Keith EI5IN was also running a low orbit satellite setup and had made some contacts on his equipment which was good considering the wind at times, I was amazed the antenna had not taken a tumble.



The IRTS HamFest2025 had come to an end on Sunday 16.00, it was a long weekend for us having left on



Friday and broken sleep too.

Was it worth it? From our point of view it was in as much we were able to show other operators our setup and what we do when on the road, it was also great to meet up with so many friends from the radio world and also our members who did make the trip to join us for the weekend.

From the point of view of the IRTS, I believe it was worth it, this being there first one will benefit them from the point of view of planning and running the next one it's a good learning curve and a brave step in taking on an event like this.

The society were not competing with HamFest UK but trying to give some insight with a little more planning and greater involvement from radio groups in Ireland, they run their own weekend.

Most of all it's a great way to meet up on site, camp over and have a laugh no matter what the weather and conditions are like and hopefully walkaway on Sunday with memories that will stay with us forever •



**John Tubritt- EI3HQB**

[ei3hqb@gmail.com](mailto:ei3hqb@gmail.com)

## Electronic Keyer



**This is a great device for those who have older radio's but want to use a modern iambic keyer**

With a stack of functions listed it, in my opinion, has one small flaw.

**STORAGE FUNCTION:** The automatic keyer has storage and segmented storage function, and usually stored using statements for work and life.

**EASY OPERATION:** The automatic key controller has 2 buttons and a switch, which is simple in structure and easy to operate and use.

**GOOD PROTECTION:** CW keyer, with power off protection function, the automatic key controller is safer to operate, widely used in radio application.

**ALUMINUM ALLOY:** The automatic keyer adopts aluminum alloy housing, which is wear and corrosion resistant, and has a long service life.

**ADJUSTMENT SWITCH:** The automatic code keyer has adjustable speed switch, and the control panel and potentiometer can be adjusted at any time

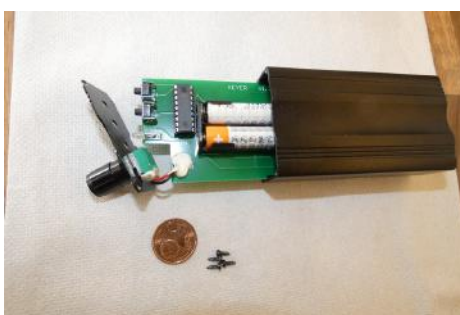

This is a battery-operated device and work very well for the cost about €15.00 it is well made and compact.

In my mind one flaw though is the battery,

changing that is it means you have to open the case every time it goes dead.

Now as you can see in the photo those tiny screws needs a jeweller's screw driver to remove them and it also needs to be magnetic so you don't lose them. But there is an alternative which cuts out all this messing so watch this space.

Once the board is out its easy to change the battery's and then reassemble the unit for me it was too much messing

and with lesser eyesight than a few years ago the thought of loosing the screws made the operation that bit more terrifying.



Looking on the board you can see the + - for the power from the battery to the board maybe a different approach was needed to fitting new battery's. so I decided id fit an external battery housing with an on of switch,

There are plenty out there on Ali Express etc. so the choice is yours and for as little as €3.00

Mine would be mounted on the back of the keyer and made easy installation of new battery's a piece of cake and of course when not in use the on/off switch would come into its own.



So back to the board and remove the wires from the internal battery pack, the replacement had a length of red/black wire fitted so no need to worry about that.



As I would not be using the internal buzzer this was removed and this gave access for the wires from external battery into the enclosure and they would be then soldered to the board.

Leave the wire as long as possible as the circuit board can only be removed from the front of the case and this will allow that to happen, when the case is reassembled the



excess wire can be tucked into the hole and out of sight. It is that simple no more fiddling with tiny screws the cover on the new battery pack just slides of and new battery's fitted in seconds.

If you have any handy tips you'd like to share just drop us a line at ei3hqb@gmail.com on any other articles you would like to include in the magazine •

**John Tubritt- EI3HQB**

[ei3hqb@gmail.com](mailto:ei3hqb@gmail.com)

# Portable Power Project

Recently I started doing portable operations like POTA. I quickly realised that I needed portable power, I had two 7 AH 12v SLA batteries, and I wanted to use them for amateur radio and make them safe and easy to use.

I broke out my trusty measuring tape and took some measurements and proceeded to draw some add-on parts for the batteries, which I then proceeded to 3D print with PLA.

My first attempt was simple and basic, where I had two Anderson power pole outlets and a fuse holder, I was very happy with the result and I used that for some time and then one night out of pure boredom I decided to add to the project by putting an on-off switch, solar charger, 19v buck converter for charging laptops, and an LCD display to show voltage.

I wasn't sure how it was going to turn out, but when finished I was pleased with the results. With one battery and a solar panel, normally, it is enough to run my Xiegu X6100 and my laptop for most of the day up to 7 hours plus.

So as a small project I found it easy to assemble and I have some photos to add to this to give a visualization of what I done.

The battery project is good enough for doing short duration outdoor

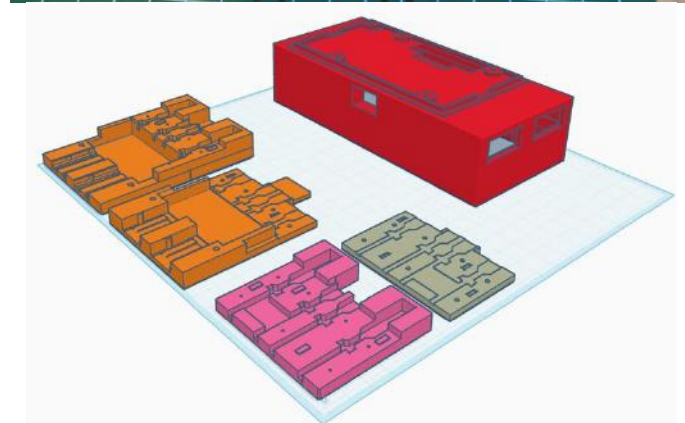
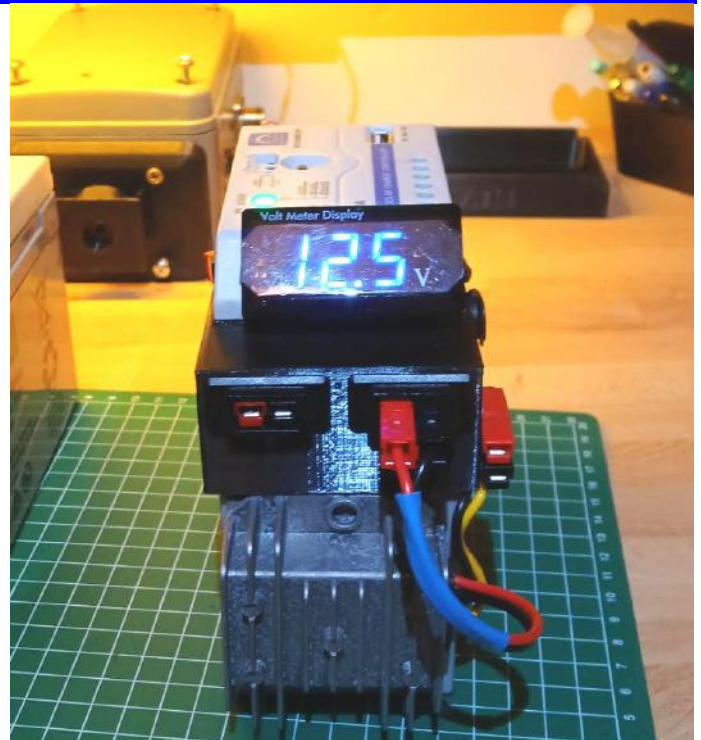
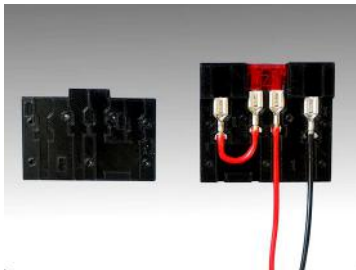
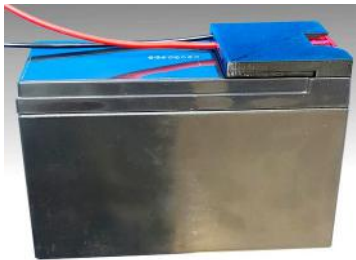

activations, the battery is compact and convenient- however- I don't think it would not be suitable for SOTA.

The battery is slightly over 2 kilos and probably a little too bit heavy to carry up mountains, but since finishing this projects I have spotted 8 AMP hour 12.8v batteries that are lifepo4 and are built in the same casing as the SLA battery so it is not a big problem to move the parts over to the new type of battery.

The reason I'm considering the lifepo4 battery is that the battery has a built in BMS and the battery only weighs in at 1kg, so I think it would be a good upgrade for the project.

The added benefit to using the lifepo4 battery is the lifepo4 battery has a higher AMP discharge rate of up to 15 Amps with stable voltage-whereas the SLA battery seems to give about 10 amps on a good day before I see a voltage drop.

The solar panel that is used to charge the battery is a 12v 25watt panel, it's a bit small, but enough to run the gear for one day •



Micheal Quilligan - E19GNB  
[ei9gnb@gmail.com](mailto:ei9gnb@gmail.com)

# Railways On The Air

This year EI3CC activated a Railway on the air station, we chose a rather unique railway in Ireland located in Listowel, Co Kerry.

In 1888, a unique railway link was opened between the towns of Ballybunion and Listowel in North Kerry. This monorail-designed system was developed by the French engineer Charles Lartigue (1834–1907), and was inspired by, of all things, a camel train! While working on a project in Algeria, Lartigue had seen how camels walked comfortably while carrying heavy loads balanced in panniers on their backs. Lartigue's inspired design had a single rail above the ground, and held at waist height on A-shaped trestles. Specially-made carriages sat astride the trestles like panniers.

We set off for our activities on a Friday which is handy as this trip was to take four hours traveling. On arrival we were met by Michael Guiren a local historian and a member of the preservation group who look after this amazing train.

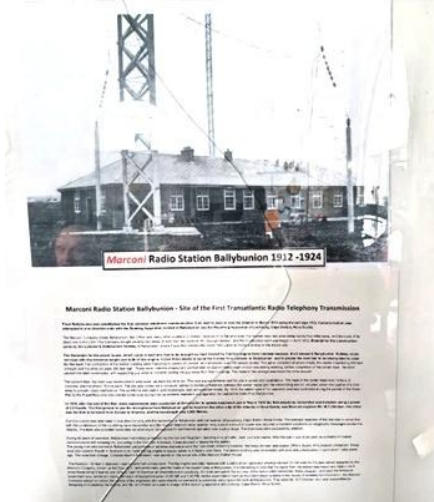

We were attracting a lot of attention from the public with an interest in what we were doing and they were stunned that we had worked other stations with again an interest in both promoting the hobby and the perseverance of the railways.

We have a member Mark EI4JIB living in Listowel who worked at the local supermarket, his company (Garvey's SUPERVALU) had sponsored us over the weekend with food etc that may be needed over the weekend and we were very appreciative of the gesture.

and had a full program for Saturday.

Heavy rain had cleared overnight and the forecast was good for the day with plenty of sun so in no time we had a station set up and running rig was the Icom7300 to an EFHW at about fifteen feet and output at about 100w.



In no time we were dealing with pile up's, because the railway was so rare it was attracting a lot of interest with other railway activations.



On the tour we were able to view some items that were salvaged from the days Marconi was in Ballybunion and surrounding areas while making contact with the USA.

Friday evening we set out where we would put the radio unit and accommodation caravan so after some food and Tea we call it a night



Some of the group had travelled a good distance to be with us at the railway and operating the radios.



# Railways On The Air



As the day progressed, Wayne EI7HKB set up the QO-100 sat system and in no time he was also dealing with pile up's one as far away as south Africa.

The equipment for the QO-100 is an 1.1mtr dish to that a SatRover is strapped and then into an old FT290R, this system works a treat and



a cheap option for working QO-100.

Later that day we had a break for our evening meal again supplied by the local supermarket and it was well needed and delicious



With a stunning evening we continued to work the radio's Liam EI7GTB from the Skywave radio club in Cork had arrived and soon they were running DMR and slow scan TV while Alex EI1895 was keeping an eye on the aircraft on the laptop.

Into Saturday night we went some staying up until 3am with plans for future events being sorted and a large consumption of tea and coffee.

Sunday, was again a sunny start and plenty of visitors making their way to meet us at the station, because we have members all over Ireland it's great to be able to move about over the year to different counties and meet up with them.

Our oldest member James who is just short of his 90<sup>th</sup> valve made a point in getting over to meet us even with the legs now getting a bit worse for wear, he was welcomed and went home later in the day a happy man with a group mug for his workshop.



In the meantime, we headed into the station for our own trip on this fantastic railway and it was a memorable experience to travel on something so rare, also to how the system worked and the train being rotated at each end of the track on the turntable.

By 3pm we had stripped the camp and we were ready for the journey home after having a wonderful time in Listowel with

wonderful people we talked on the mobiles of the return trip in 2026 and it can't come fast enough.



If you are ever in the area then make a point of calling to see this wonderful railway run by a dedicated group of people who will make you more than welcome.

We have a video on our YouTube channel of this and many more of our trips out so take a look and better still give us a like and subscribe to us also

<https://www.youtube.com/channel/UC1A1qJM-kdhq-cKiHV6zu0A>

If you have any article you would like to include in our magazine please feel free to email me at [ei3hqb@gmail.com](mailto:ei3hqb@gmail.com) or [wright14@gmail.com](mailto:wright14@gmail.com) and we will gladly include it in future editions •

**John Tubritt- EI3HQB**

[ei3hqb@gmail.com](mailto:ei3hqb@gmail.com)

# THE K.S.O.B. Wire Beams Part 1

**G**reetings from the shed once again. Today's subject is about wire beams I have built over the years and even the strange one or two even done and worked on and made them work. Wire beams? What's the first thing comes to mind besides the Moxon and the Full Wave Quad type of antennas in forms of beams of my efforts with wire beams

## The Moxons

So let's get on with the first one, but a simple easy to make type such as the 2 El Moxon beam with wire elements strung up of frame works or X frames, the fav called spreaders to suspend the wires into the air usually Hoz mount but have been noted vertical as well. Now if you go on the Internet you can find a good on Line calculator and input the freq you want to use etc it will come up with something like this. [http://w4.vp9kf.com/moxon\\_design.htm](http://w4.vp9kf.com/moxon_design.htm)

But me, being me, I take it one further and have made three Element Moxon's. Once you have the design sizes via the web site. With the 3<sup>rd</sup> element which is the director element at the front. Yet in what I have found, take the size of the driver element and reduce size of your director element by 5% BUT keep the front length same as the reflector and driver and what's left over tailing back will fall into place. Now the gap between the driver and the reflector again take that gap and reduce by 5%. Now you will have the 3 El Moxon beam. And tell you what? They do well work over a 2 EL version.... BUT have found the impedance falls somewhat from a 2 El to a 3EL beam.

So if you are wanting a 2element 10m Moxon for SSB, for I set mine at 28500khz but by adding a 3<sup>rd</sup> EL, you need to drop it down by 500khz to 28mhz in your on line calculation . The reflector and driven element need to be tad little longer as well the gaps. Same with doing CW sized 28Mhz but if doing 3El set it to 27.500khz. And again set the director forward element again by reducing 5% over all from the main driver element. BUT word of warning, I have tried doing more than 3 El to a Moxon and the impedance just falls off the planet and no longer tunes in at all, let alone resonates. Otherwise if you don't re do the sizing for 3 El, the Good ATU will adjust this nicely.

## Now to the designs I have built in past .....

My first effort was a 2EL 10m Moxon beam but with a twist? I wanted to bring in its overall width inwards and managed to do this by folding back the elements underneath and reducing the overall width. But back and forth elements distance reminds the same. And it actually worked well but bit bug ugly as the frame work was centred around 25mm conduit and using 1.6mm hard drawn copper wire and still have a good impedance of 50ohms and worked number of stations across Europe on Es.. But was not a safe antenna through its design with the conduit and quite cumbersome and heavy and awkward to put up. But as an experiment, making folded 10M Moxon beam worked!

The next Moxon I built was the T6M. So called in short for a Tri Element 6m band Moxon. This really worked well as I set it to 50.150mhz on its centre and used the

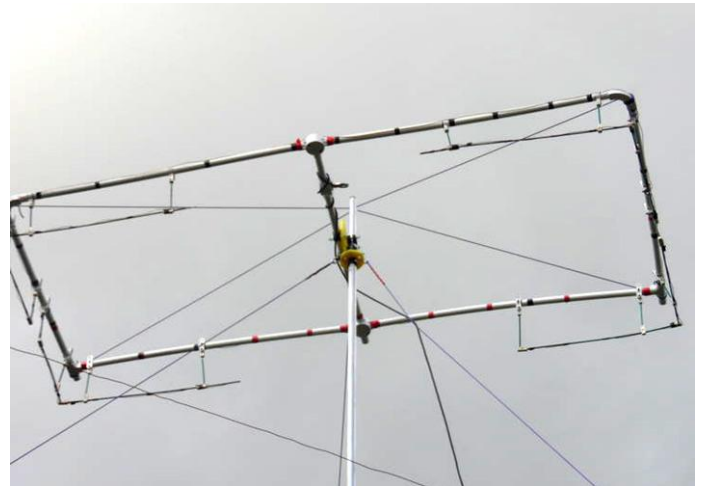

MFJ949D to tune it in and it did very well on Es as far as the Ukraine and even on Multi hop ES into East coast Canada a couple of times and even into Malta and Cyprus again Via Es. This was a frame work of 20mm conduit as the frame laced with 1.6mm hard drawn copper wire and straight Fed with 50 ohm coax.



Again flimsy by nature, note the centre rod using support rope from each corner of the Moxon beam itself to hold it together and stop it flopping about. Defo had to come up with better framework. So that is a Three el beam for 6m in 2 EL Moxon + 1 design.

Hence the T6M was born and worked many stations off the Es conditions with only in this case 10w as was only a M3 then and limited with 10w PEP on both above 3 El Moxons.

Last year I did build a nice full wave loop for 2m but a portable version that back packs away in small bag and slap on a squid 10m pole. Tunes in a treat and works well from higher



# THE K.S.O.B. Wire Beams Part 1

points you can reach and its light weight fort back packing. The spreaders are 15mm PVC water pipe and fittings.

The latest Wire beam I built was the 10M 3EI Moxon using tent poles as spreaders and riot plexi-glass plastic sheets and 25mm Ali boom. This was set too 28.5Mhz on the design calculator and future plans is to re set the design to 28mhz. Thus, is making the elements a tad little longer and element spacing again a little bigger. But again note the bridge wire to support the weight across the boom. To extend the arms of the spreaders, am going to insert M6 stainless studding and nuts. This will allow the extra length I need and also tension up the spreader and antenna wire formation.



SSB was rather good but no doubt not good as me 4EI wire Quad.

My next story will me Wire beams part 2, but the full wave Quad types defo good antennas for VHF and above and tech easy to build and use as I have from 60m through to Quagis hitting 70cms.

'Till next month all best from the Kernow shed of build from a forgotten corner of Cornwall •



Micheal Quilligan - 2E0FEH  
[ei9gnb@gmail.com](mailto:ei9gnb@gmail.com)



Above is the general design of antenna with its spreaders and boom and the plexi-glass. It's been up and used during spring months and managed to work into Sota's in VK, LU and South Africa as well chatted with a guy in VK9. In this case thanks to new rule changes this year me out put power gone from 50w to 90w. Make's one hell of a difference.

I found that one can switch in the MFJ949D and work 6m off it and ended up working East coast USA on 6m



**Link to Channel**

<https://batc.org.uk/live/rsgb>

**Live Webinars**  
**Streaming Live on Monday 6th**  
**October 2025 at 8pm**  
**VK73WW: 100K QSOs**  
**from the**  
**Pacific Ocean**

**3rd November 2025**  
**Improving Speech Clarity with DSP**  
**by**  
**Graham Somerville**

## DARC Celebrates Its 75th Birthday

The weekend starting on Friday 29<sup>th</sup> to Sunday 31<sup>st</sup> August was no ordinary weekend for our vice chairman, Peter (DH1NGP) and his unusual vehicle. As owner of a former Danish outside broadcasting Mercedes van, he took part in the celebration of the German Amateur Radio Club (DARC) in Baunatal, close to Kassel, the headquarters of this club in the middle of Germany.



Together with Thomas (DG4SAS), who also owns a special VW T4 van that was used by the German authorities for controlling radio transmissions, they had planned to arrive at 8.00 o'clock on Saturday morning. Peter even visited the B44 field day in Stettberg between Rothenburg o.d. Taube and Ansbach in Bavaria.

electrically driven and four 100Ah batteries for power that makes this van a highlight to see. It is equipped with different ham radios and measuring units for transmitters making it a perfect candidate for the celebration event. It still has a rack with the original equipment for the Danish radio broadcasting that was used, demonstrating its former operation.



With such a strong argument the decision from the DARC was quickly made to allow Peter to take part. Peter added to the application the Volkswagen T4 van from our fellow member, Thomas, who also owns a mobile unit of the German radio and television officials responsible for controlling and measuring transmissions. It has also a Geroh mast and is his mobile ham unit. With these two vans, Peter and Thomas (having to get up a half hour earlier to meet up with Peter and driving 285km to get to Baunatal) represented the DARC Franken Area and the B44 Club.

On Friday, he left that evening early to head to his bed, having to get up at 4 o'clock in the morning to arrive in Baunatal at a planned 08.00AM but little did he realise that not always does everything goes to plan.

Arriving shortly before their aim, the planning was delayed by a roadworks not allowing vehicles higher as 2,80m through. With a height of 3,10m with retracted mast, Peter and Thomas was forced to take a detour that made them arrive ten minutes too late for the official start in Baunatal marketplace before the townhall. Despite this delay, Peter and Thomas were quickly escorted to their positions on the marketplace and made preparations for presenting their vehicles. The Geroh masts are extended on both vans by using a 10m Spider beam, giving a nearly 20m height in total, with a wire antenna to cover a wide range of frequencies. The wire antennas are changeable depending what frequency you want to use. Peter is a shortwave fan of morse and is very active using many beautiful morsing keys. Thomas has an unbelievable amount of units and technic that he uses which he loves to present and explain.



For any other radio operator to get the chance to take part in this 75-year celebration it is a privilege. The DARC had made a written request for any members who had an unusual radio set-up and were prepared to come to Baunatal to take part in the celebration to make a written application. Peter had his beautiful former Danish radio outside broadcast Mercedes van that he has been transforming to a mobile ham radio workshop and transmitting unit. It has a 9m Geroh mast that is

The two vans had many visitors as did the many stands that was presenting the amateur radio club and the many different aspects of this hobby. With around 2000 to 2200 visitors the marketplace was quickly full. Peter had his van's radio tuned to 14MHz for demonstrating and needed around a 40m 220Volt power cable to provide the much-needed power. This allowed him to turn on all his units and show the versatility of this van. He even has a mobile router giving him an internet access for his logging and monitoring what activity is on the many ham radio

# DARC Celebrates Its 75th Birthday

bands. To look into his van and seeing the technology that he has installed is not just a beautiful mixture of different units with its lighting but a pure well thought out mobile station with every possible technic for communication. Not to forget, it is also a mobile radio workshop, allowing Peter to drive his van to his customers.



The birthday event on this marketplace was also filled with food trucks, a fire brigade, emergency radio trailers and German official transmissions monitoring units. Commercial companies were also representing their products. A big name like Kenwood was there as well as other well-known German manufacture/shops like Hilberling, Dathe and Bonito.



The DARC has its own publisher for books which was also presented. Many members of the DARC presented their studies in the many aspects of ham radio to the public. There was two large halls used for presentations that went for an hour. Officially open to the public from 10.00AM till 17.00PM, this was a well organised and successful celebration of 75 years DARC.



For Peter, Thomas and other participants of the event, the DARC offered a VIP allowance to take part in the evening meal. Arriving at 18.15PM for the invitation, they got a greetings drink and got to hear the opening speech. As a highlight, the German President, Mr. Steinmeier, gave a greeting per video to the visitors. The Town Mayor of Baunatal and the President Minister of Hessen held also their opening speeches so that the buffet was opened at around 20.00PM. With 500 invited guests, the DARC gave an excellent meal with a variety of starters, main meals and deserts.

After the meal a presentation to the history of the German amateur radio and the development leading to the forming of the DARC was held. Starting in 1925, the DFTV was grounded and later renamed as the DASD. Due to the political expression and the Second World War, the DASD was dissolved. After the war, it took five years and long discussions to form the now known DARC. In Bad Homburg during the shortwave radio event, on 10th September,



eight regional clubs joined together to form the DARC.

Further highlights of the 75 years of the DARC history was mentioned and the night was ended with music and dancing starting at around 22.30PM. For Peter and Thomas, the day of taking part had come to an end (Peter just did not tell me if it is because he cannot dance). They left for at least a three-hour trip to head back home. Peter arrived at around 02.30AM home and was up early, again, to take part in his club B44 field day event in Stettberg. Peter even got Thomas to come to this event, despite coming later to bed.

All in all, it was a well organised event with many displays of what the amateur radio has developed into and what is possible for the modern-day operator. With information speakers and the numerous stands full of information, the DARC 75 years celebration in Baunatal turned into a great source for any person interested in the hobby of radio communications. Who knows what the DARC will achieve in the next 25 years and can show in their 100 years anniversary •

**Marten Toonder**

[martentoonder67@gmail.com](mailto:martentoonder67@gmail.com)

## DARC B44 Club Field Day in Stettberg, Bavaria

Starting on Friday 29<sup>th</sup> August, the DARC B44 field day in Stettberg began in the afternoon. Stettberg is located between Rothenburg ob den Taube and Ansbach in Bavaria, Germany. It is an old stone quarry that was used for ship sandstone and was closed down in 1955. The quarry has turned into an ideal place for the local youth club who hold musical events here. It has a 220 volt power supply box with distributor and a toilet with its own water connection, making it also an ideal place for a radio club event. Thanks to Momo (DG9NDT), our chairman of the DARC B44 club and his connection to the ELJ Binzwangen (the local youth club) he won us for the second time the access to this ideal location with approximately 470m height.

One of the first visitors. Michael, who owns a former Mercedes fire brigade lorry, got his truck on a beautiful position to become one of the first vehicles to be seen when you arrived on this location. His truck is always a welcome guest, being equipped with tools, power generator, a fridge, a fixed installed German army Geroh telescopic hand winched mast and on its roof, a tent box where Michael slept for all of the days of this event.



He even had extra heavy-duty tires that were even ideal for driving off road and gave his lorry that 'extra' look. With Michael in position, a few others turned up, including our Momo and his wife, to spend the early evening at a

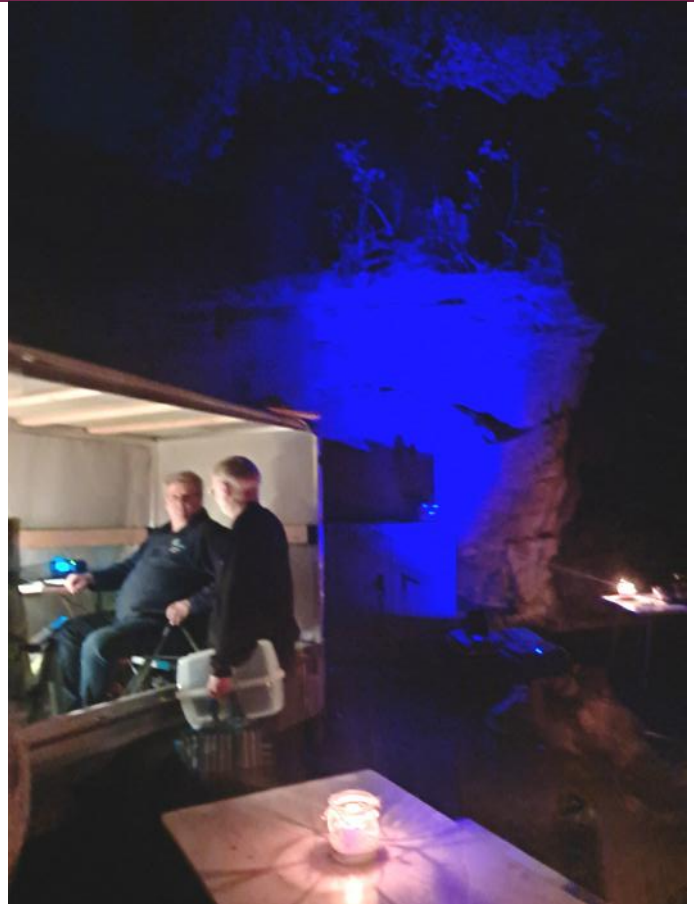

fire. Sitting around the fire, many stories were told till the later hours.

We broke up after hearing that a storm warning for heavy rain and thunder and lightning was to be expected. It was this kind of weather forecasts that followed us for this weekend, making the turnout of visitors that came to be surprisingly more as expected. Heading home, I was confronted with a few drops of rain, never saw or heard the thunder and lightning that we were warned for. Returning to Stettberg the next day, Michael told us that only a few drops of rain fell and nothing else. This was a blessing because the Stettberg is on a hill with a small dirt road as entrance and the whole area being grassed that would turn into mud with all the cars and vans turning up, had it rained heavily.

On Saturday, I was surprised to see so many cars on the mountain so early. Many visitors had come to help build up the event and look at those who were already there. Uwe (DK3UH) had planned to build his QO100 system but unfortunately forgot a piece of equipment and had to return to a FT 8 system setup and 'normal' communications with



# DARC B44 Club Field Day in Stettberg, Bavaria



speech. He had his mobile home packed with the necessary mast and radio equipment with computer, so he was still able to communicate to the world. Momo arrived a bit delayed with a trailer full of needed different utensils and equipment. With the trailer emptied, it was reused as platform for a table with a Yaesu FT-897 and three chairs. To complete the setup, I used my 18m Spider beam with a 16m wire connected to a 1:9 Balun. With this unit I had the great pleasure to use a trainee callsign and, under the guidance of Momo, I made my first QSO to New York state. Later, Wolfgang, our new member successfully made a QSO to Finland.

the taking down of his antenna.



The event had numerous visitors from our own club or from neighbouring DARC clubs. Even friends and relatives came to visit this field day. A special guest came with his pickup with a home cabin built on the loading area. What was unusual? This cabin was hand built over a one-and-a-half-year period and looked as if it came from a factory. The strangest guest appearance goes to an old man on his electric chair. He saw the antennas and vehicles from a distance and wanted to know what was going on. I offered him to build a transceiver with antenna on his chair, so that he could talk to us but he was not interested. He was thankful for the conversation and that we were prepared to answer his questions but his curiosity was quickly stilled. He left us and thinking back, I still was worried that his battery capacity was strong enough for him to get home. I think he made it because till date I have not heard of a missing person with an electric chair.

We left Stettberg after cleaning up, disconnecting the water for the toilet and turning off all the power connections. It was an active weekend, leaving me exhausted on Sunday. The fun in taking part in such an event and meeting others, plus the highlight of being on air, again, after a very long break from ham radio, made the weekend a positive memory. Looking forward to the next DARC B44 field day and seeing all those who took part and all new guests •



**Marten Toonder**

[martentoonder67@gmail.com](mailto:martentoonder67@gmail.com)



For Dominik (DL1DH) was one of our unusual visitors as he came on his bike from Burgbernheim, a town about 12 Km away. He immediately had the pleasure to use Michael's setup on his fire brigade. Michael had installed a second Fiberglass mast from DX Wire which had a wire antenna for CB and on his Geroh

mast he had a 2m/70cm duo band antenna. For Dominik the chance to see which repeaters was possible to reach from the Stettberg. Searching on his app on his phone, he tried the numerous relays that he could find. On Sunday, the final day, we had Peter (DH1NGP) and Thomas (DG4SAS) turning up with their beautiful vans. They had only a few hours of sleep, having spent the previous day at the 75 years anniversary of the DARC (German Amateur Radio Club). Reporting of their experience from the previous day exchanged, they both got their masts put up and started to use their transceivers. With the day flying by, we started to disassemble our equipment and repack Momo's trailer or help Michael with

# Gordon's Expedition to Ireland Part 1

**M**y name is Gordon and my UK callsign is G3PXT. Following the loss of my wife of 52.5 years, I decided to take time to tour Ireland.

I came to Ireland August 2024 but due to a road accident and writing off my 2000 Honda CRV. I bought another Honda CRV this time a 2006 mk2 petrol ex auto. I removed the front passenger seat, and the rear passenger seat & fitted an 8ft platform bed with 6inch memory foam mattress 2ft wide.

In the rear is a table and with the driver's seat fully folded forward I have a sitting area which allows me to run my FT-710 with computer connection and 8inch monitor. The power supply is either my black line 2.2KVA generator or 2 x 100 AH lead acid batteries in the passenger's foot well with split charger.

Apart from the generator other kit is an electric kettle, hot plate, microwave, portable toilet, 6 plastic boxes with radio kit, food cooking things, clothes vacuum packed to take up less room spare power supply spare FT-710, lap top, gas stove, seat tent, shelter tent, rucksack, 2x 20 litre Jerry cans for petrol and 30 litres of water and fire extinguisher

I left Norfolk 31 May 2025 to catch ferry from Holyhead to Dublin with a stop in Kings Lynn Norfolk to sort out pet passport cheaper than local vet online. We, myself and Bubbles the dog, arrived in Dublin 4th June and a local amateur in Rush offered his drive for the night when we arrived, we were told that his XYL had fixed up the

spare room for us. We then left to head to Northern Ireland where we had an invite for coffee in Lurgan which again turned into a spare room for the night.

From Lurgan we went to Collin mountain and wild camped up in the mountains we put the 10m mast up on the drive over plate with my full size 40m inverted Vee antenna and used the call G13PXT/P.

The next day Belfast Castle asked if i could set up aerial was told as long as it did not obstruct pedestrians i could do what I liked. I then spoke with Paul, a local amateur, and he agreed to meet me the following day in Belfast to show me around. I had my own personal tour guide who even treated me to coffee and cake, and we spent 5 hrs looking around Belfast.

The following day we headed for Donaghadee, Larne, Bangor Dunluce Castle then on to Londonderry.

We then headed to the most northerly point in El Malin Head using the call EI/G3PXT/P. We had no planned route but just moved as we thought fit 50-100 miles a day enjoying the sites off motorways on minor roads as we wished to see Ireland not cars.

We stopped at bloody foreland on the 18th June and arrived at John, EI5JTB's QTH in Ruskey to park in his drive and where

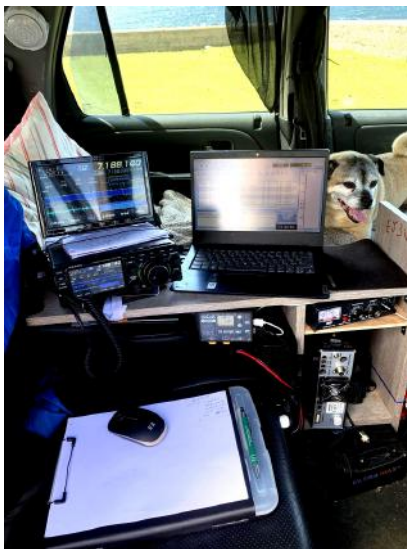

# Gordon's Expedition to Ireland Part 1

offered the annex with bathroom stove and shack.

Our travel continued from Arranmore Island to Glen Colmcille - the locations are picked at random just find some where to park up and set up aerials as my Honda does not look like camper van, I can get away with parking in most places. From there to St Johns' head long peninsular into Donegal bay and then to Rosses point, Sligo.

From Arranmore Island to Glen Colmcille - the locations are picked at random just find some where to park up and set up aerials as my Honda does not look like camper van, I can get away with parking in most places.

From there to St Johns' head long peninsular into Donegal Bay and then to Rosses point Sligo, Vince, a short-wave listener kindly emailed me said I was passing his house and invited me to drop in for coffee. His friend Vince, in Ballymote, offered me his drive for me to park in with electric hook up. Mike wanted to put up a new aerial, so I offered my assistance.

Together we installed a 10ft mast, a Discone antenna, a halyard for a dipole, and reinstalled a 10m vertical and a 2m vertical on a new 20ft mast and installed coax cables. Yes, that is me standing on the chimney.

My travels continued to Coney Island which is accessible via a causeway at low tide. Coney Island is very small with only 4 full time residents and 12 holiday homes. It has a small bar which serves excellent Guinness. I left Coney to finish the work on Vince's antenna installation before moving on to Benwee Head.

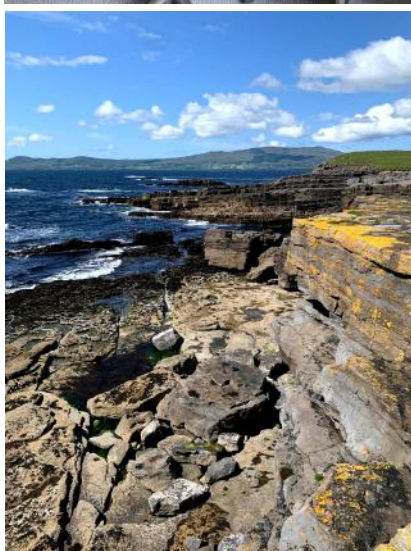
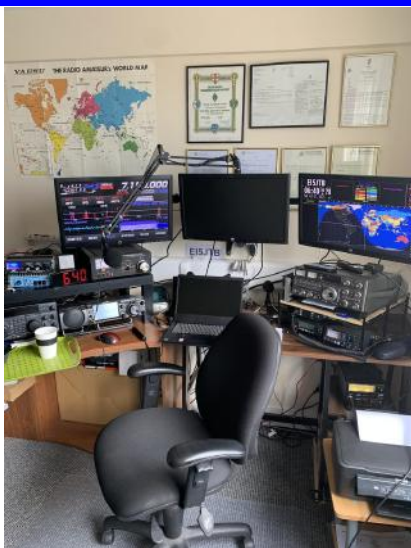

I was interested in Bunkers, Lighthouses and Castles and made a point of seeking them out on my travels. I had no set itinerary. At each stop I would put up my 10m mast on a drive plate. This would support my 40m inverted Vee antenna.

I could fire up the generator to power the equipment and would work on 40m, 15m or 6m with excellent results. I operated from locations between Benwee head and Erris Head with a minimum of 30 QSOs from each location.

At Blacksod beach, I decided to have a swim. IT was the first time in 30 years! Blacksod Lighthouse was close by and I gather this played a pivotal role in the D-Day Landings by passing on weather reports which were the deciding factor for the go ahead.

My next destination was Clare Island which is situated off the coast of Mayo. This is accessible by the boat from Roonagh Pier. I had to go full portable from this location as there was no car ferry available.

I put together a kiy consisting of the FT-710, Laptop, 10m mast, and 40m dipole. In addition, I brought food and a tent. I managed 164 QSOs before the battery failed on the laptop and then the one powering the rig. •



*My travels continue in the December Issue of Ham Radio Ireland*

Gordon Higgins - G3PXT / EI3VP  
g3pxt1948@gmail.com

# Skywave Amateur Radio Club



Skywave Amateur Radio Club was established in 2018 to cater for like-minded amateur radio operators interested in the technical and fun aspects of

radio operation. We represent the interests of radio enthusiasts in the Cork region and beyond.

Our aim is to generate an interest in amateur radio and to introduce newcomers to our hobby while enjoying the benefits of group and community activities.

There is something for everyone, no matter what your age or level of interest. Learn morse code if that's your thing or build your own radio transmitters and raspberry projects. (during the summer of 2025 the [ei0sw.com](http://ei0sw.com) website went green and is hosted on a raspberry pi zero 2W running from solar power.

have another interacting with us spreading the name of the hobby.

We run various formats from a HF station to various digi modes from meshtastic to slow scan TV these always attract a good audience and being science week at the observatory there are plenty on spectators.



We EI0SW, in return, take a trip up to Waterford where we spend the weekend helping out with the EI3CC JOTA, they have a number of scout groups so the total on the ground can be as high as 75 scouts .



So its all hands on deck, our part in the weekend can vary each year but one item that has proven very popular is astrology. Mick EI9GNB brings along his very impressive telescope and the scouts get to view whats in the solar system above their heads.

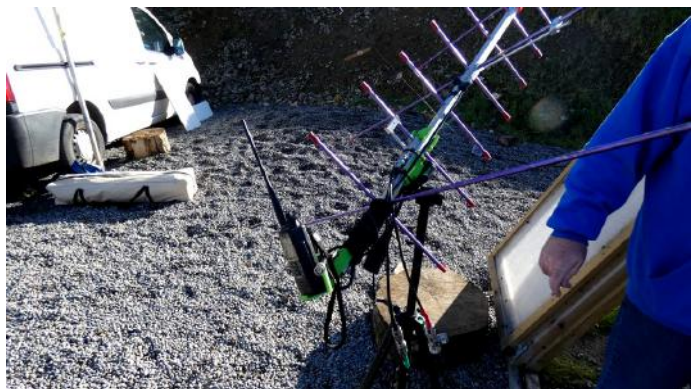

One thing every club should do is interact with other clubs and with this in mind we have been proud to be able to interact on a few activations with EI3CC.

EI3CC joined us at the BlackRock observatory Cork. We run a station from the site and invite the public to see and demonstrate what our hobby is about, and its great to



We also demonstrate low orbit satellite which again with the scouts fully engrossed with the work and challenge involved in catching a satellite and making contact thru it to other stations.

The JOTA weekend is a great way of encouraging youth into our hobby and Skywave always make a point of promoting youth and our hobby where we can.

Membership of the Skywave Amateur Radio Club is open to anyone with a genuine interest in the hobby of amateur radio and all it encompasses and a genuine interest in the goals of the club •

# My Dad's Weird Hobby

Ok, so my dad has this... thing. It's in the spare room, taking up half the desk, with all these wires and blinking lights. He calls it his "shack," which sounds way cooler than it actually is. It's basically a bunch of boxes connected to antennas that snake out the window like metallic vines. And the noise? Oh my gosh, the noise. Sometimes it's just static, a never-ending hiss that drives me crazy. Other times, it's these weird, crackly voices that sound like they're coming from another planet

Dad calls it "ham radio". Apparently, he talks to people all over the world using it. Like, actual people. Not on the internet, but through the airwaves. It sounds totally ancient, right? I mean, who needs a special radio when you have TikTok and Instagram?

Honestly, for the longest time, I just thought it was his weird old-man hobby. Like how Mr. Henderson down the street collects garden gnomes. It was just... there. I'd occasionally hear him in his "shack," saying things like "CQ, CQ," which sounds like he's trying to call a flock of seagulls. Or he'd be scribbling stuff in a book, filled with these strange letters and numbers that looked like alien code.

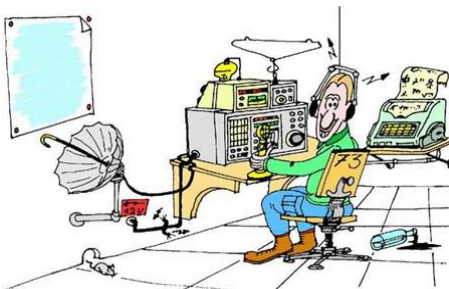

Sometimes, when we have family gatherings, his ham radio friends come over. They're all... enthusiastic. Like, *\*really\** enthusiastic. They talk about things

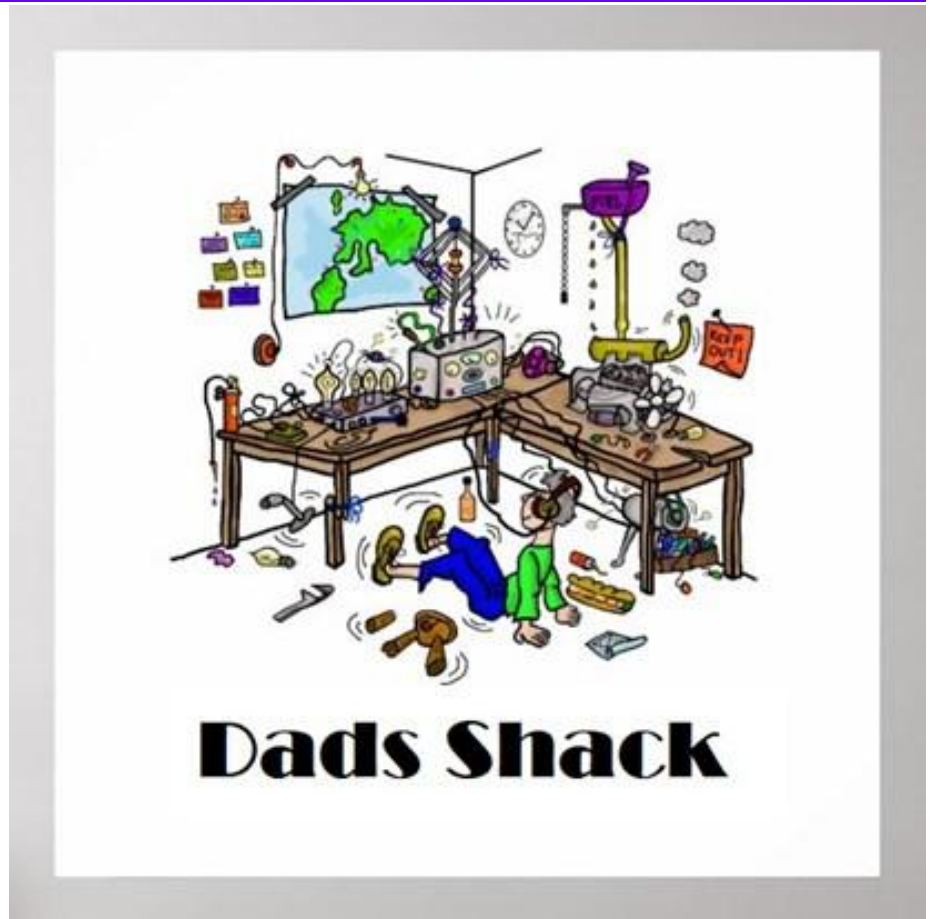
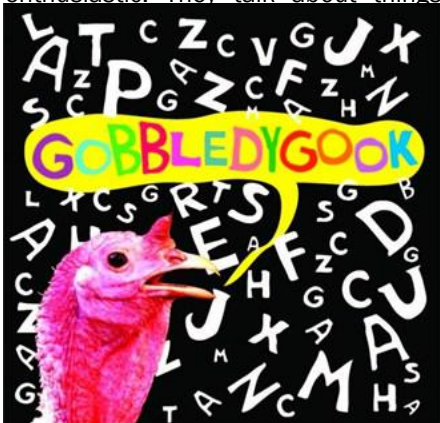

like "propagation" and "SWR" and "antennas" with this intense passion that I just don't get. It's like they're speaking a whole different language, and I'm stuck in a silent movie.

He's tried to explain it to me, of course. He talks about "making contacts" and "DXing" (which apparently means talking to faraway places). He even showed me his QSL cards -

these postcards people send each other after they've talked on the radio. Some of them are actually pretty cool, with pictures of different countries and flags. But it still feels a bit like he's living in a time capsule.

My friend Amy thinks it's kind of cool in a retro way. She said it's like having a secret communication system. And I guess there's a tiny part of me that's a little bit curious. Like, who are these people he's talking to? What are they saying? Is it all just static and crackly voices, or are there actual conversations happening in that weird little room?

Maybe one day, when I'm really, really, *\*really\** bored, I'll actually ask him to show me what it's all about. Maybe I'll even try talking into that funny-looking microphone. But for now, Dad's "shack" and his mysterious ham radio world remain one of the slightly baffling, slightly embarrassing, but ultimately... well, it's just Dad's thing. And who knows, maybe one day I'll finally try to decode the static •



Meadhb Sexton



Irish Built Telescopic Mast  
086 870 9265

*CUSTOM BUILT*  
*MAST CONVERSIONS*  
*DRIVE ON SUPPORT*  
*CUSTOM T-K BRACKET*



# bhi

# HEAR THOSE WEAK SIGNALS CLEARLY WITH A BHI DSP NOISE CANCELLING PRODUCT!

**DON'T PUT UP WITH NOISE & INTERFERENCE ANY LONGER**

**VISIT OUR WEBSITE**



### PARAPRO EQ20 RANGE

- Greatly improved audio for those with hearing loss
- Two separate mono inputs or one stereo input
- Use with passive speakers or headphones
- Use with any radio including SDR
- Three different options available



### DUAL IN-LINE

- Fully featured dual channel DSP noise cancelling in-line module
- 8 Filter levels 9 to 40dB
- 3.5mm speaker level input
- Line level input for SDR radio and headphone output
- Easy-to-use controls



### COMPACT IN-LINE

- Powerful audio processor
- Removes noise and interference
- Hear weak signals clearly
- Easy to use with "real-time" audio adjustment
- Use with headphones or a loudspeaker



### NES10-2 MK4

- 5W amplified DSP noise cancelling speaker
- 8 to 40dB noise cancelling
- Audio bypass feature
- Use mobile or base station
- Supplied with integral 2M audio lead, fused DC power lead & manual



### DESKTOP MKII

- 10W Amplified DSP noise cancelling base station speaker
- Easy-to-use controls
- 8 DSP filter levels
- "Real-time" adjustment
- Suitable for all radios including SDR
- Loudspeaker and line-level inputs



### NEDSP1962-KBD

- Amplified DSP noise cancelling PCB module
- Easy to install retrofit module
- Audio bypass feature
- Simple control with LED and audio indication

# bhi

[bhi-ltd.com](http://bhi-ltd.com)  
[info@bhi-ltd.com](mailto:info@bhi-ltd.com)

**Testimonial - Mr. B Hiley**  
"The DESKTOP speaker is great, audio is crisp and clear, brilliant!"



**CONTACT US**  
01444 870333



**My name is Adam Sweeney, and in 2026 I plan to be the youngest Irish person to summit Mount Everest, the tallest mountain in the world at the age of 22, with the current youngest being 26.**

**In February of this year I completed my first big mountain - the highest mountain in South America, Aconcagua standing at 6961m in The Andes. With a success rate of only 30% I was delighted to make it to the summit with no problems with fitness, skill, or altitude sickness. As far as I am aware, at 20 years of age, I am the youngest Irish person to summit Aconcagua, but I could be proved wrong with that fact!!**

**Summitting Aconcagua in the Argentinian Andes, my first 7 summit, has given me the confidence to move on with my dream.**

**In November 2024 I plan to climb Ama Dablam with an Irish Team in Nepal. At 6,812 meters which is slightly lower than Aconcagua but it is a step up in technicality and a natural training ground for Everest.**

**In May 2025, I'll be going to Alaska to tackle Denali, the highest mountain in North America. The approach to Denali is a challenge in itself, where I will have to haul my expedition gear on a sled to Base Camp, taking 3-4 days. The summit attempt itself will take 21 days, with time taken acclimatising to the mountain altitude, before an assault to the top which stands at 6190m. This is a fully self-sufficient trip and a great mental test before Everest.**

**With your support, we can create human history and be the youngest Irish person ever to summit Everest, the worlds highest mountain.**

**Thank you ,  
Adam Sweeney**

**You can help by clicking on the link below or by copy and pasting the link into your browser and donating to my Go Fund Me page**

**[https://www.gofundme.com/f/adam-become-the-youngest-irish-person-to-summit-everestfbclid=PAZXh0bgNhZW0CMTEAAaZxMo4nC-TUp0397g\\_vjJK24WSq1nNqSC6W-egf10HzXYIQTHxu80UjcXk\\_aem\\_i7TyCaN4SJcFBR3vkpmCLQ](https://www.gofundme.com/f/adam-become-the-youngest-irish-person-to-summit-everestfbclid=PAZXh0bgNhZW0CMTEAAaZxMo4nC-TUp0397g_vjJK24WSq1nNqSC6W-egf10HzXYIQTHxu80UjcXk_aem_i7TyCaN4SJcFBR3vkpmCLQ)**



## DAW Electronics

My business is a comprehensive repair facility now based for the last 6 years in South Wales. I have a country wide client base and special thanks to all my customers so far for that. In the last 6 years I have repaired and serviced somewhere in the region of 2000 radios varying from military Clansman to some of the latest Amateur radio and CB equipment. As a time served engineer for the last 40 years, I have a good knowledge base from VLF to microwave equipment solid state and valved. To new and old clients, I would like to thank you for your support and trust in my service.

Email: [dave.g4tiw@hotmail.co.uk](mailto:dave.g4tiw@hotmail.co.uk)

Mobile: 0044 7785294926

(Monday to Friday Business Hours: 9 - 6pm)



Summits on the Air is an amateur radio awards scheme. To participate in this scheme you do not become a "member", there are no dues to be paid or membership cards to be issued. You can join in straight away! Just go to [SOTAwatch](http://SOTAwatch) to see what is happening right now in SOTA. To

post to SOTA facilities you will need to [register an account](#) and then you will be able to add alerts and spots on SOTAwatch (which will likely help a lot, if you plan to activate) and upload your chases or activations to the SOTA database. There is no charge for registering. The [SOTA Reflector](#) uses a separate user account system; so to join in with discussions there simply click on the "Sign Up" button. We recommend that you save a copy of your passwords in a safe place - every week

we have to help people who have forgotten their passwords!

You can then Chase or Activate when you feel like it - SOTA is global, activations can take place throughout the 24 hours of the day. Once you transfer your log to the database there is a permanent record and you can check your entries against those of the stations that you contacted, and keep track of your progress towards awards. Later you might wish to purchase awards, trophies or goods from our on-line shop. These purchases and the occasional donation are the means of financing the SOTA facilities.

### More information:

<https://www.irts.ie/dnloads/sota.pdf>

<https://www.sota.org.uk/>

## ZachTek

Handmade products for radio amateurs and RF enthusiasts.

Welcome to ZachTek, here you will find RF related products and information.

Some of my more popular products are different models of WSPR transmitters that is made for the radio amateur that wants a standalone transmitter for mobile or stationary use.

With these in your shack you can run WSPR 24/7 without tying up your regular transceiver.

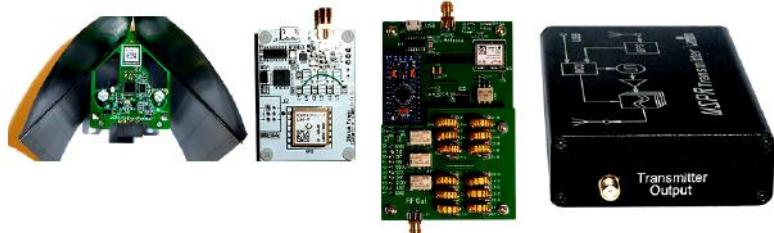

## QRP LABS

<http://shop.qrp-labs.com/>

Check us out  
Many projects here  
are capable of  
transmitting and receiving  
WSPR

# Drop by our Online SolderSmoke Store



<https://www.cafepress.com/soldersmoke>

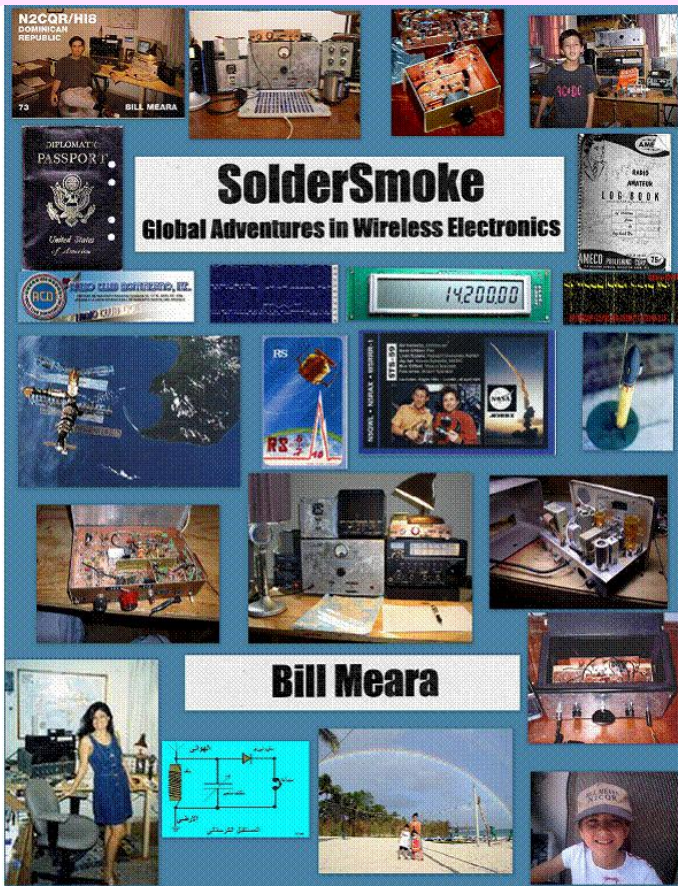

**SolderSmoke**  
Global Adventures in Wireless Electronics

**Bill Meara**

If you know  
stuff... you  
can do stuff.



[soldersmoke.blogspot.com](https://soldersmoke.blogspot.com)

Books are available from the  
Lulu Website:

<https://www.lulu.com/>

## SOLDER SMOKE THE PODCAST

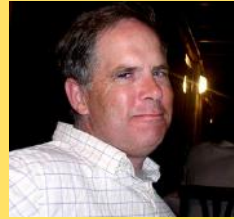

Host - Bill N2CQR

**Serving the world-  
wide community of  
radio and electronic  
homebrewers**



Co Host - Dean  
KK4DAS



Co Host - Pete N6QW

<https://soldersmoke.blogspot.com/>

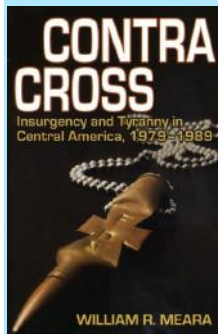

A journey through the Central American wars of the 1980s as seen through the eyes of a young American officer who worked on both sides of the insurgency in the region: In El Salvador Bill Meara supported efforts to defeat insurgents; with Nicaraguans he worked to keep an insurgency alive. One of very few Americans to see both sides up close, he takes readers into his world as an advisor struggling with cultural differences and human rights violations while trying to stay alive in murderous El Salvador. We join him on dangerous helicopter rides into contra base camps on the Honduran-Nicaraguan border and into a U.S. Embassy under attack. From Special Forces school at Ft. Bragg to Joan Baez's back-stage party in Managua to a contra POW camp deep in the jungle, we get a taste of Meara's world up close.

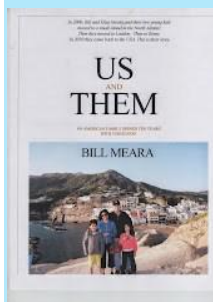

What happens if you take an American family and send them to Europe for ten years? In the summer of 2000, Bill and Elisa Meara, accompanied by 2 year-old Billy and 4 month-old Maria, left their home in the suburbs of Washington, D.C. and moved to the Azores. There they experienced the highs and lows of diplomatic life on a small distant island. After three years in the Azores, they spent four years

London and three years in Rome. Overseas they lived in two houses and two apartments, went to five schools, used four different health care systems, experienced one earthquake, 9-11, the terrorist attack on London, tea with the Queen, the election of Barack Obama... and all the ordinary things that families go through. They lived mostly with the locals, learned Portuguese, Italian, and a bit of Cockney, and made many friends (foreign friends!) They returned to the United States in 2010 with a changed view of the world. This is their story

AVIONIC – EXPERIMENTER / AMATEUR – MARINE RADIO

## Clearance

### My Junk is your GOLD

Antennas - PSUs - AC Adaptors - Voltage Converters - Laptop  
Power Supplies - Garmin Stuff - Ethernet Switches - Routers  
WiFi units - Connectors - Books & more

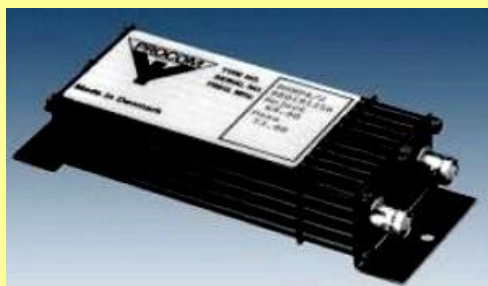

Contact Us  
00 353 (0)87 2552578  
wescomradio@gmail.com  
Deerpark, Oranmore,  
Co. Galway, H91 X2YH



When Icom say they listen to their customers,  
they *really* listen to their customers



**NEW! Icom IC-7300 MK2  
HF/50/70MHz 100W Transceiver**



**IC-7300 MK2 Highlights**

- ✓ Improved RMDR and Phase Noise Characteristics
- ✓ Lower Heat Generation and Power Consumption
- ✓ HDMI™ Port for External Display
- ✓ RX Antenna IN/OUT Connectors
- ✓ Built-in CW Decoder
- ✓ Simplified RS-BA1 Remote Control
- ✓ USB Type-C™ with Dual COM + Audio
- ✓ \*RMDR: Reciprocal Mixing Dynamic Range
- ✓ The successor to the world-renowned IC-7300, the new IC-7300MK2 builds on a legacy of excellence with enhanced performance and innovative features – setting a new standard for HF operation.

\*Please note that specifications may be subject to change

For more information see [HamRadio.co.uk/IC7300mk2](http://HamRadio.co.uk/IC7300mk2)

**NEW! Icom ID-5200  
2/70 Mobile or Base FM/  
D-Star Transceiver**

The ID-5200 is a versatile dual-band transceiver supporting both FM and DV (Digital Voice) modes, with the ability to perform simultaneous dual reception of FM-FM, FM-DV and DV-DV signals.

- ✓ Touchscreen Operation – Intuitive touchscreen interface for quick access to functions and settings.
- ✓ Broad Reception – Receive VHF, UHF and Airband signals for extended listening options.
- ✓ Wi-Fi & Bluetooth – Built-in connectivity for seamless integration with other devices.
- ✓ Internal Gateway Function – Connect to Wi-Fi and operate in terminal mode or access point mode for flexible networking.
- ✓ DV Repeater Monitoring – Dedicated repeater monitoring function keeps you connected.



For more information and availability  
see [HamRadio.co.uk/ID5200](http://HamRadio.co.uk/ID5200)



**MARTIN LYNCH & SONS LTD**  
THE WORLD'S FAVOURITE HAMSTORE

**OUTSIDE THE ULEZ ZONE!** Wessex House, Drake Avenue, Staines, Middlesex TW18 2AP UK  
Tel: 0345 2300 599. International Tel: +44 1932 567 333. E-mail: [sales@hamradio.co.uk](mailto:sales@hamradio.co.uk)  
Opening Hours: Mon - Fri: 8.30am to 5pm. Sat: 9am to 4.30pm

**SAFE ONLINE SHOPPING**  
[www.HamRadio.co.uk](http://www.HamRadio.co.uk)

The Original HamRadio Store @ HamRadio.co.uk with no hyphens, extra words thrown in or anything else to confuse you.