



Dodge Grand Caravan

Northstar[®], Summit[™], and Northstar E[™] Conversions





VMI Northstar®

Power In-Floor Ramp

VMI pioneered the Northstar in-floor ramp system in 1993 to satisfy wheelchair user needs for additional interior space and a safe, clean, obstruction-free vehicle interior. After two decades of refinement, the Northstar remains the most technologically advanced ramp system on the market. The Northstar ramp simply slides out from within the vehicle floor, rather than taking up valuable space inside the vehicle. The significant advantages of the Northstar in-floor ramp system over traditional fold-out ramps make it VMI's best-selling conversion.



Obstruction-Free Doorway

Safe entry and exit without deploying the ramp for able-bodied passengers.



Interior Space

Ample interior space for wheelchair maneuverability.



PowerKneel®

Lowers the vehicle to provide a reduced ramp angle for easy entry & exit. Can be deactivated for deployment onto a curb.



Stowed ramp is protected within the vehicle floor with no squeaking or rattling. In-floor ramp keeps dirt and debris from entering the vehicle cabin.



Sure Deploy®

Provides a simple way to operate the ramp in the event of vehicle power loss.



VMI Summit™

Power Fold-Out Ramp

The VMI Summit fold-out ramp system features a fully powered, fold-out ramp. The Summit ramp stows inside the vehicle cabin and smoothly extends outward when deployed. The ramp is designed with 2" side rails to provide an additional level of comfort when negotiating up and down the ramp.



Easy Access to Door Handle

VMI's Summit ramp does not block the interior sliding door handle.



PowerKneel®

Lowers the vehicle to provide a reduced ramp angle for easy entry & exit. Can be deactivated for deployment onto a curb.



Ramp Perforations

The ramp perforations help remove debris and provide additional traction for wheelchair access.



The anti-rattle mechanism helps to ensure a quieter ride.



Rounded Corners

Rounded ramp corners make it easier to maneuver up and down the ramp in tight parking situations.



VMI Northstar E™

Manual In-Floor Ramp

The Northstar E manual conversion is designed for wheelchair users with caregivers. Its simple design features front-seat wheelchair access and an in-floor, slide-out ramp. With all of the core elements of a functional mobility vehicle, the Northstar E offers practicality, ease of use, and other side-entry benefits at an affordable price. The patented manual in-floor ramp of the Northstar E is easier to stow and deploy than other manual ramp options on the market, and it does not take up valuable interior cabin space when stowed.



Easy Manual In-Floor Ramp

Easy to use for caregivers of any age or size, requiring no bending or heavy lifting.



Flexible Seating Options

Optional single or double flip-up mid-row seating allows a caregiver to sit next to a wheelchair user in the front or mid-row.



The Northstar E has seating capacity for up to 7 people!



Obstruction-Free Doorway

Safe entry and exit without deploying the ramp for able-bodied passengers.



Interior Space

Ample interior space for wheelchair maneuverability.

1 EASY TO USE

2 ELEMENTARY

3 ECONOMICAL

Standard Features



One-Touch Controls

One-touch controls make it easy to deploy or stow the fully powered Northstar or Summit ramp system using the OEM remote, VMI dash button, or other interior vehicle buttons!

Not available on the Northstar E manual conversion.



All VMI van conversions come with 3 year / 36,000 mile* warranty coverage!

** whichever comes first*



Easy Front Row Access

The front row floor is free of obstacles to accommodate wheelchairs in the driver and front passenger positions.



Removable front seats are equipped with rolling casters, making them easy to remove and lock back into place.

Driver seat not removable in the Northstar E.



Front and Mid-Row Access

Wheelchair users can sit in the front row or mid row in any VMI conversion.



Lowered Floor

Allows the wheelchair user a clear line of sight and provides ample headroom for most users.



Engineered to minimize interior noise.



Ground Clearance

High clearance reduces scraping caused by speed bumps, crested pavement, or dips.



100% Crash Tested

Meets or exceeds all Federal Motor Vehicle Safety Standards governed by NHTSA (National Highway Traffic Safety Administration).

Optional Features



Step Flares

- Allows easy access to front-row seating on both driver and passenger sides
- Microspike textured non-slip surface
- 400 lb weight capacity
- Color-matched to each vehicle



Durafloor

- Unique rubberized flooring
- Provides excellent traction for wheelchairs
- Durable and easy to clean
- Full layer of insulation reduces noise



Seating Options

Multiple seating options for VMI's Dodge Grand Caravan conversions allow for independence and flexibility. Wheelchair users can choose to drive from their chair*, sit in the front passenger position, or ride in the middle of the van. This diagram shows just a few of the many possible seating options.

Northstar and Summit

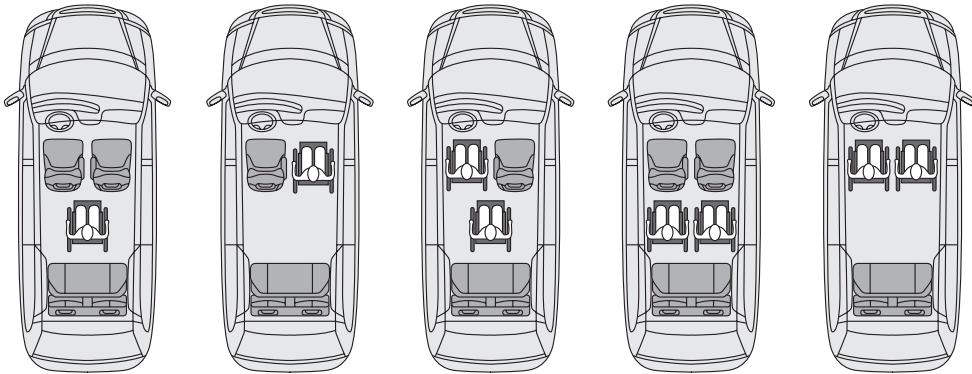

Northstar E

Without Mid-Row Seat

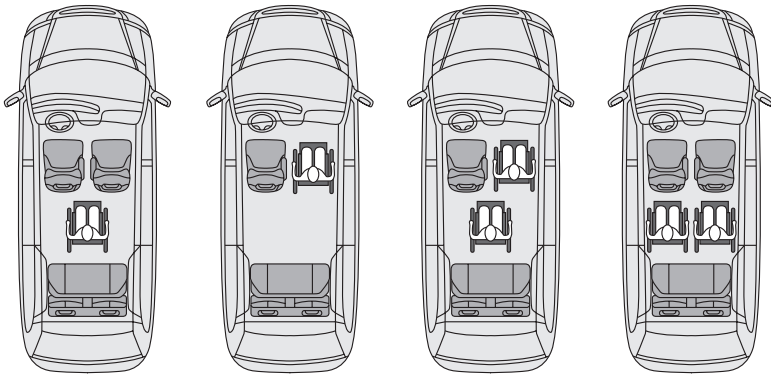

With Single Mid-Row Seat

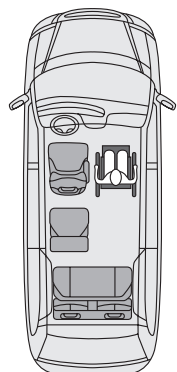

With Double Mid-Row Seat

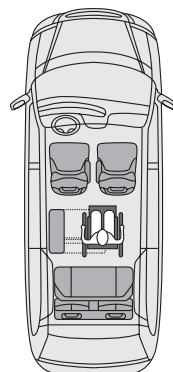
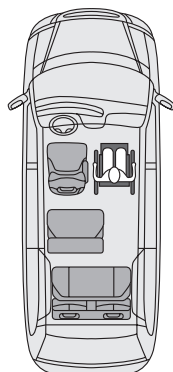
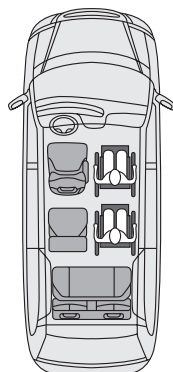
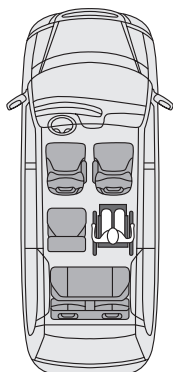

*Wheelchair users cannot drive from their wheelchair in the Northstar E conversion because the front driver seat is not removable.

The single and double mid-row seats can fold up when not in use to allow more interior space. Seating options may vary.

Specifications

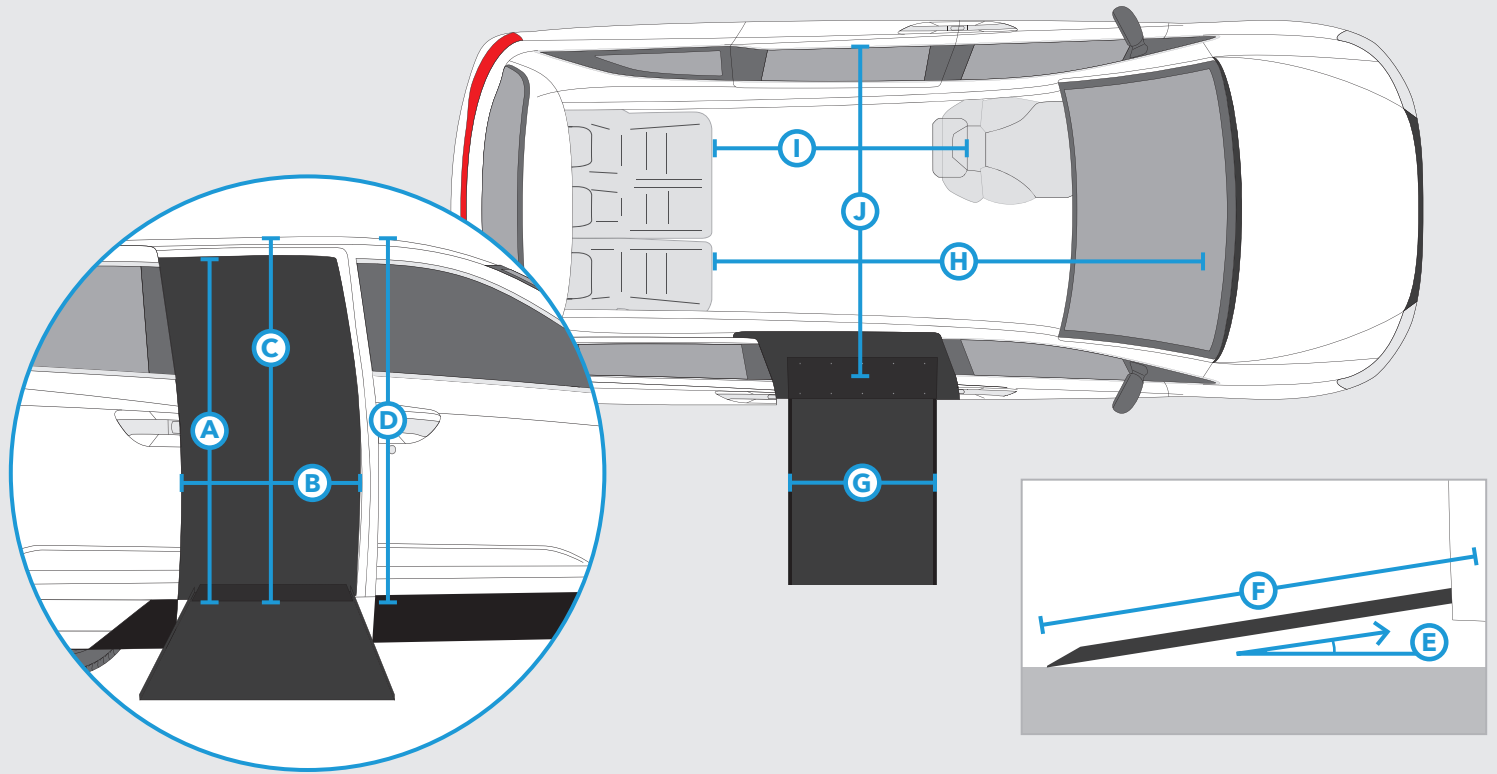

	Northstar	Summit	Northstar E
A Door Opening Height	54.8"	54"	54"
B Door Opening Width	30.1"	30.1"	31.3"
C Interior Height at Center Position	58.1"	58.1"	58.1"
D Interior Height at Front Position	57.8"	58.1"	58.1"
E Ramp Angle	9.2° (w/ PowerKneel on)	10.9° (w/ PowerKneel on)	12.2°
F Ramp Length (angled ramp and transition plate)	58.8"	49.8"	59.6"
G Ramp Width (usable)	28.8"	28.8"	29"
Ramp Capacity	1000 lbs	600 lbs	1000 lbs
H Floor Length Overall	86"	85.8"	86"
I Floor Length Behind Front Seats (from B pillar)	61.3"	61"	61.3"
J Floor Width (no mid-row seat)	67"	63.4"	67"
Floor Width w/ Mid-Row Seat Folded Up	-	-	49"
Floor Width w/ Mid-Row Seat Folded Down	-	-	37" single 22.5" double
Ground Clearance	5.5"	5.5"	5.5"
Overall Vehicle Height	74.3" (w/ roof rails)	74.3"	74.5" (at antennae)

Specifications apply to 2019 VMI Dodge Grand Caravan conversions. Measurements may vary based on vehicle trim levels and environmental factors. To ensure best vehicle fit, please visit with your local dealer to confirm vehicle measurements prior to purchase. All information is subject to change without notice. © 2019 Vantage Mobility International. All rights reserved.



Imagining Possibilities in Everything We Do

For more than 30 years, VMI has applied its innovation and expertise to build advanced mobility products that allow our customers to experience greater freedom and access to life. We are committed to you and understand how transportation can bring you greater freedom and independence. Our quality, state-of-the-art lineup of mobility products provides ease of use, maneuverability and flexibility. All of our vans have been 100% crash tested and include a 3 year / 36,000 mile (*whichever comes first*) conversion warranty.



Dealer Network

Our more than 500 dealers are trained to carefully evaluate each customer and his or her unique needs in order to recommend the right mobility product. It's all part of our commitment to provide superior customer service and the most fulfilling ownership experience.



MQAP Certified

Fully meets compliance requirement standards instituted by the National Mobility Equipment Dealers Association for manufacturer quality assurance.



Proud Member
Since 1990



Proud Sponsor
Since 1999



855-VMI-VANS • vmivans.com • 5202 S 28th Place Phoenix, AZ 85040
(864-8267)