

# WHEELERFIT

WQ12024

## AIR SPRING CATALOG



wheelerfleet.com  
866.439.2329

# TOTAL COVERAGE FOR THE ROAD AHEAD

**WHEELER FIT OFFERS HEAVY-DUTY AFTERMARKET PARTS THAT FIT YOUR TRUCK, YOUR BUSINESS, AND YOUR BUDGET.**

Wheeler Fit offers a line of aftermarket replacement air springs manufactured by Fabio that can provide years of service and thousands of miles of performance. Our air springs deliver uptime to you by reducing vibrations, which reduces stress on other truck components and provide a comfortable, quiet ride for your drivers.

## WHEELER FIT AIR SPRINGS OFFER:

- Higher fuel economy through plastic assembly
- Increased driver comfort by dampening vibrations
- Fit, form, and function matches OEM specifications
- Increased load hauling stability
- Durable and reliable performance



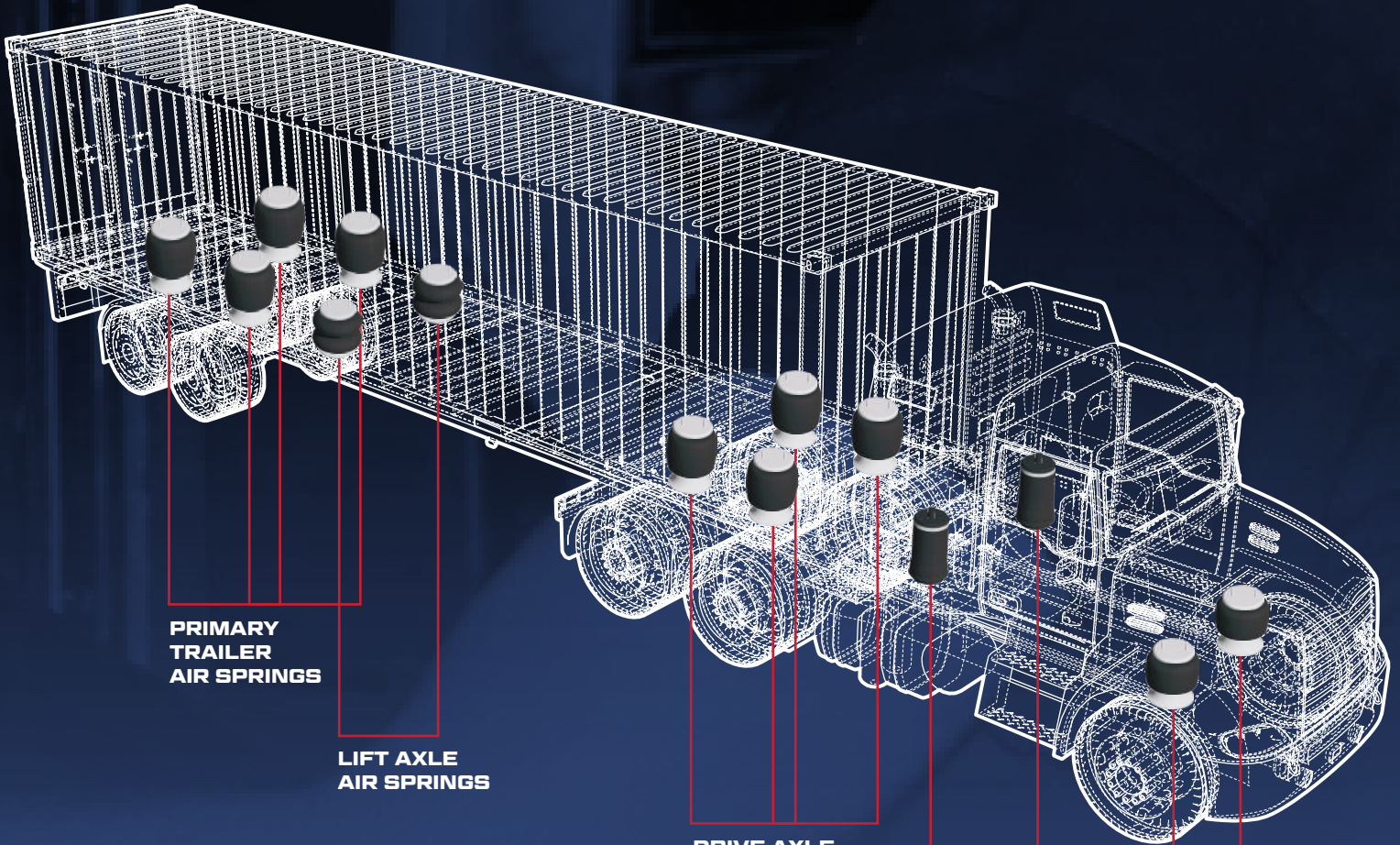

**PRIMARY  
TRAILER  
AIR SPRINGS**

**LIFT AXLE  
AIR SPRINGS**

**DRIVE AXLE  
AIR SPRINGS**

**CAB  
AIR SPRINGS**

**STEERING  
AIR SPRINGS**

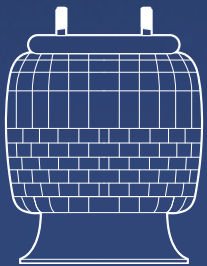

**Rolling Lobe  
Air Springs  
PAGE 1-9**

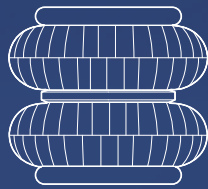

**Convoluted  
Air Springs  
PAGE 9-10**



**Cab  
Air Springs  
PAGE 10**

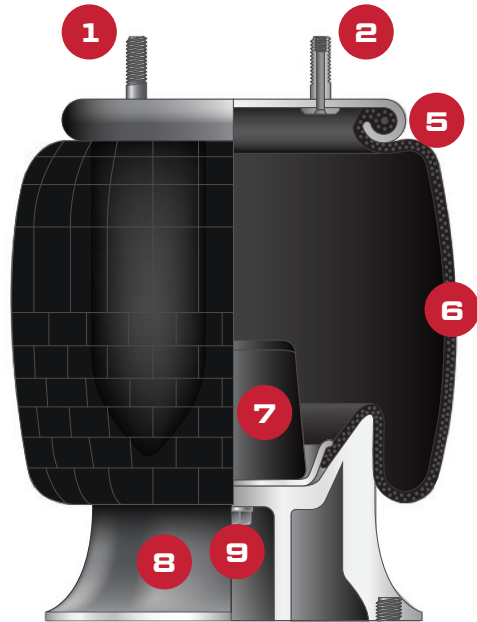

**Rolling Lobe Airspring**

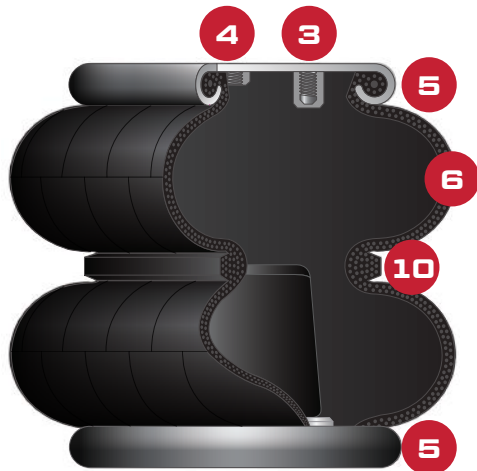

**Convoluted Airspring**

## Airspring Components

### 1. Stud

A permanent part of the bead plate assembly, used to attach the air spring to the suspension.

### 2. Combo Stud

Combination mounting stud and air fitting.

### 3. Blind Nut

A tapped hole that provides an air entrance for the part.

### 4. Air Fitting Hole

A permanent part of the bead plate assembly, used to attach the air spring to the suspension.

### 5. Bead Plate

Steel plate, permanently crimped to the bellows to form an airtight assembly.

### 6. Bellows

The air spring bellows is a flexible, airtight composite of rubber and reinforced fabric, which allows the assembly to roll up and down, providing an air-cushioned spring effect within the suspension.

### 7. Bumper (Optional)

A solid, molded rubber fail-safe device used on many suspension applications. Prevents excessive damage to vehicle and suspension in the case of sudden air pressure loss.

### 8. Piston

The lower section of the 1T and 1X style of air spring made from aluminum, steel, or fiber reinforced composite. Provides lower mounting arrangement for the air spring in the form of tapped holes or studs.

### 9. Piston Bolt

Attaches the piston to the bellows assembly. Extended on the bottom of the piston, in some cases, to serve as a means of attaching the spring to the suspension.

### 10. Girdle Hoop

A ring molded into the bellows of the convoluted type air spring

## **Wheeler Fit Air Springs by Fabio Maintenance Checklist**

Our Wheeler Fit air springs were designed to give our customers years of reliable service. However, you should inspect your air springs as part of your routine maintenance schedule. The following items should be checked periodically:

- 1** Inspect the outside of the air spring for irregular wear or cracking.

---

- 2** Inspect the airlines and the OD of the air spring to ensure that there is no contact between them. An air line can rub a hole in the air spring.

---

- 3** Check for sufficient clearance around the spring while at maximum diameter.

---

- 4** Inspect the piston for foreign materials.

---

- 5** Verify that the ride height is correct. The vehicle ride height can be verified in your service manual, and it should be maintained within  $\frac{1}{4}$ ".

---

- 6** Clean and inspect the leveling valves.

---

- 7** Inspect shock absorbers for leaks or broken components.

---

- 8** Check all mounting hardware, and if loose, re-torque to manufacturer's specifications.

### **Safety Tips**

#### **DON'T ATTEMPT TO SERVICE THE AIR SUSPENSION ON A TRUCK OR TRAILER WITH THE AIR SPRINGS INFLATED.**

- Don't inflate an air spring unless it's properly installed and secured.
- Don't allow the pressure to exceed 100 psi / 7 bar, or there is a possible risk of injury.
- Maintain a service temperature between -40 deg C (-44 deg F) and 70 deg C (154 deg F).
- Clean only with soap and water. DON'T use mineral, hydraulic or lubricant oils, organic solvents or abrasive cleaners. Store in a dry, dark storage at room temperature.

## DAMAGES OF AIR SPRINGS CAUSED BY EXTERNAL EFFECTS AND HOW TO PREVENT THEM

Our Wheeler Fit air springs are backed by a two year warranty. This warranty takes effect from the date of your invoice. Wheeler Fleet Solutions is not responsible for any failure resulting from incorrect installation or maintenance. Wheeler Fleet Solutions cannot accept liability for products in case of improper use, handling, storage or assembly.

This warranty statement is for general informational purpose. All warranty claims are subject to Wheeler Fleet Solutions general terms and conditions for sales, delivery and payments term as it pertains to air springs for commercial vehicles. If you have any questions about correct fitting, maintenance or storage please contact our customer service team. They will be happy to assist you.

### DEFORMED AIR SPRINGS

#### PROBLEMS / CAUSES

- Improper storage
- Improper handling
- Improper transport



#### SOLUTIONS

- Store Airsprings at room temperature, and away from direct sunlight
- Avoid improper handling
- Avoid improper transport

### CONICAL BEADS DAMAGE AND CUTS

#### PROBLEMS / CAUSES

- Improperly mounted bead plate
- Pinching of the bellows with metal parts



#### SOLUTIONS

- Keep conical beads clean and corrosion free
- Avoid driving without pressure in the air suspension

### BELLOW RUBS OFF AT SHOULDER

#### PROBLEMS / CAUSES

- Bead plate diameter incorrect
- Bellows too long for application



#### SOLUTIONS

- Make sure to use original parts
- Avoid wrong cross references

## BROKEN OFF THREAD BOLTS

### PROBLEMS / CAUSES

- Excessive torque
- Use of oils or lubricants



### SOLUTIONS

- Do not exceed recommended torque
- Avoid usage of oils or lubricants

## OVEREXTENSION

### PROBLEMS / CAUSES

- Spring Travel Not Restricted
- Incorrectly Adjusted Level Control
- Air Spring Not Suitable for Application



### SOLUTIONS

- Keep conical beads clean and corrosion free
- Avoid driving without pressure in the air suspension

## ABRASION BELLOW DAMAGE

### PROBLEMS / CAUSES

- Bellows contract with chassis parts
- Bellows contract with foreign objects/debris

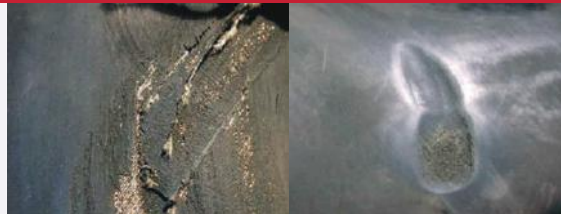

### SOLUTIONS

- Double check if the air spring fits the oe part number
- Check regularly and remove foreign objects stuck between bellows

## AIR SPRING BURST/BROKEN PISTON

### PROBLEMS / CAUSES

- Overloaded airspring
- Exceeding the maximum allowable pressure



### SOLUTIONS

- Never Exceed the Maximal Allowed Weight of the Vehicle

## CHEMICAL CONTAMINATION

### PROBLEMS / CAUSES

- Overloaded airspring
- Exceeding the maximum allowable pressure

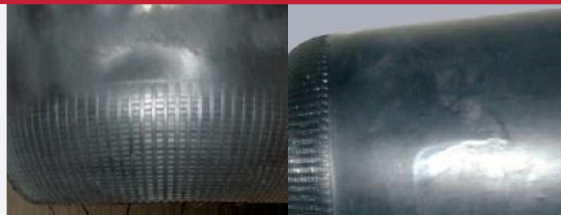

### SOLUTIONS

- Never Exceed the Maximal Allowed Weight of the Vehicle

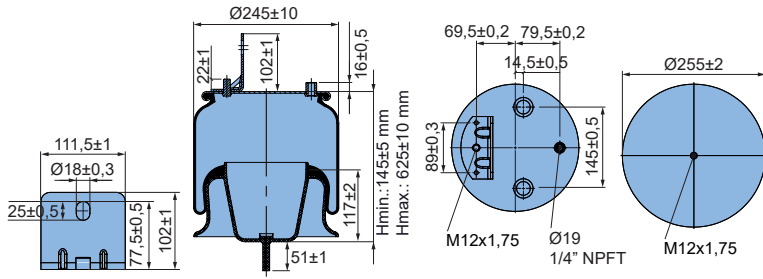

## PART NUMBER: 3827-1191

### COMPLETE TYPE WITH PLASTIC PISTON

#### OEM REFERENCE

INTERNATIONAL 3541731C1, NAVISTAR/FLEETRITE 350243C94

#### CROSS REFERENCE

9 10S-18 P 1067, W01-358-9875, W01-358-1191, W01-358-1192, 1T15XR-9, AS1191, 1R12-689, 1R12-432, 566-24-3-165, AS PR9MR18 1191, AS-81067, AS10673

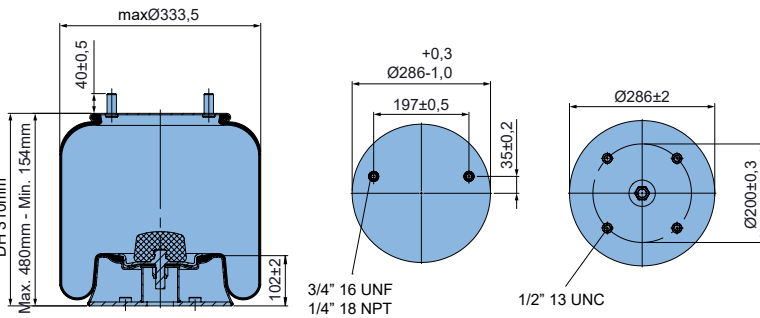

## PART NUMBER: 3827-8050

### COMPLETE TYPE WITH PLASTIC PISTON

#### OEM REFERENCE

HENDRICKSON TRAILER S4771. HENDRICKSON CANADA B-12514-013, TUTHILL REYCO 23631-01, WATSON & CHALIN AS-0039

#### CROSS REFERENCE

W01-358-8050, FLTA1R14039, AS8050, 57008050, 8320, 1R14-039, 1R14-055, 1R14-083, 1110.5C-16, S-4771

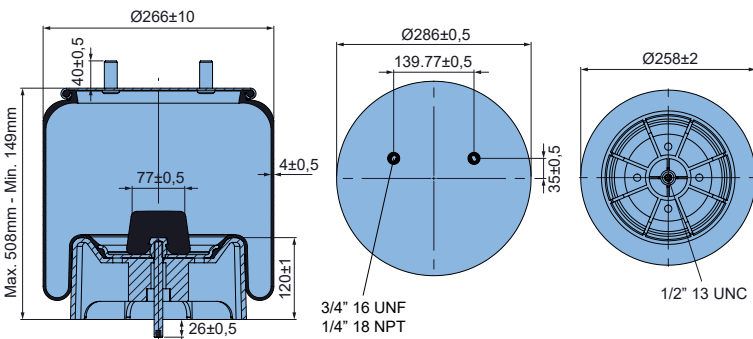

## PART NUMBER: 3827-8091

### COMPLETE TYPE WITH STEEL PISTON

#### OEM REFERENCE

HENDRICKSON TRAILER S20901 (INTRAUX 250), REUSE METAL DISK, HENDRICKSON TRAILER S21784 W/METAL DISK PISTON SUPPORT

#### CROSS REFERENCE

W01-358-8091, AS8091, FLTA1R14171, S21784, 8523, 1R14-171, 1T19FC-6, S20901

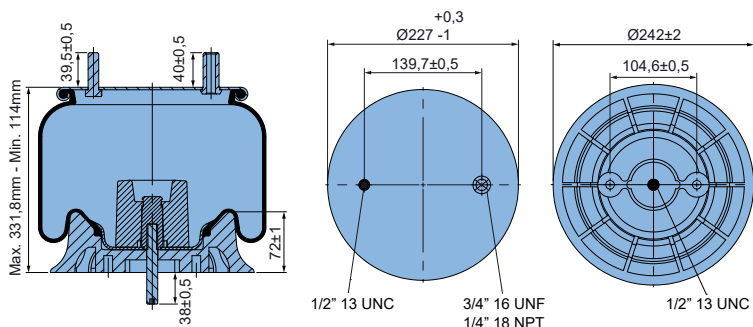

## PART NUMBER: 3827-8204

### COMPLETE TYPE WITH STEEL PISTON

#### OEM REFERENCE

HOLLAND (NEWAY) 90557173 (RL196A-12), HOLLAND (NEWAY) 90557223, BINKLEY NEWLITE (NS 190-16)

#### CROSS REFERENCE

W01-358-8204, 90557173, 90557223, 8484, AS8204, FLTA1R12508, 1R12-522

# THE RIGHT FIT FOR THE ROAD AHEAD

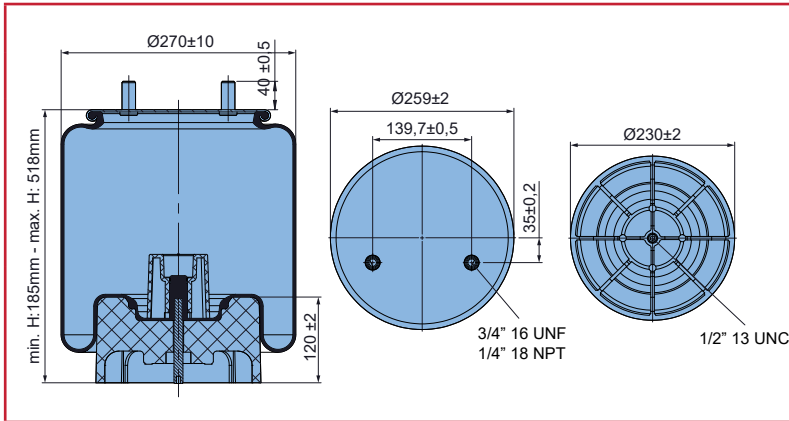

## PART NUMBER: 3827-8708

COMPLETE TYPE WITH PLASTIC PISTON

### OEM REFERENCE

HENDRICKSON TRAILER S21966 (HKA200 SPECIAL)

### CROSS REFERENCE

W01-358-8708, AS8708, FLTA1R13177, S21966, 8526, 10 10-16S526, 1R13-128, 1T17CA-6.5

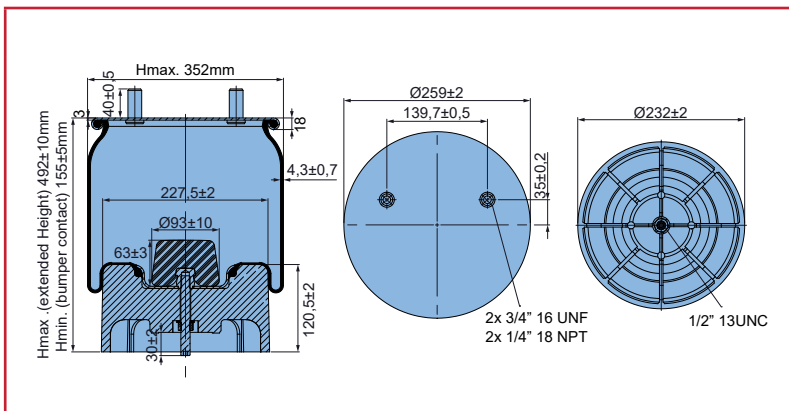

## PART NUMBER: 3827-8709

COMPLETE TYPE WITH STEEL PISTON

### OEM REFERENCE

HENDRICKSON TRAILER S21800 (INTRAAX AA230 - 8/1997-UP)

### CROSS REFERENCE

AS8709, FLTA1R13159, W01-358-8709, 1010515P460, 8460

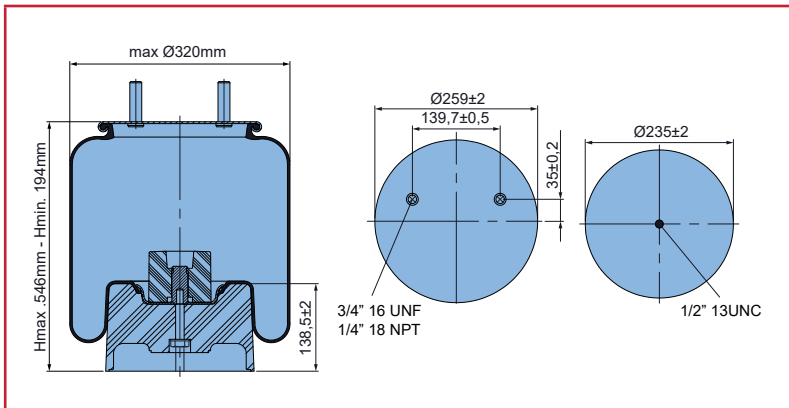

## PART NUMBER: 3827-8713

COMPLETE TYPE WITH PLASTIC PISTON

### OEM REFERENCE

HENDRICKSON TRAILER S22948 (VAN TRAAX HKA-180)

### CROSS REFERENCE

W01-358-8713, 8533, S22948, FLTA1R13176, 1R13-176

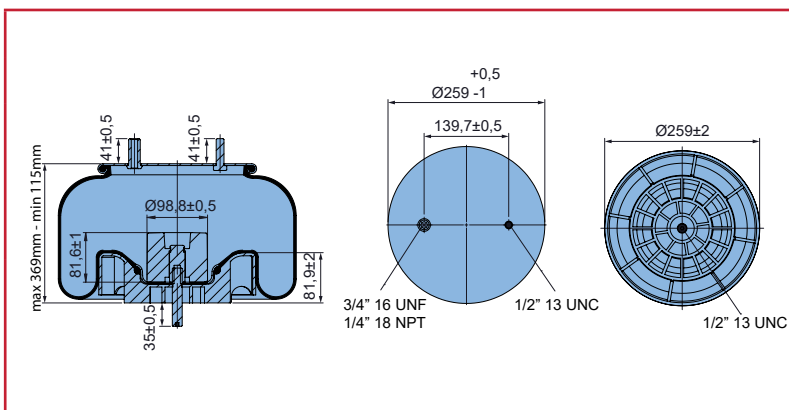

## PART NUMBER: 3827-8729

COMPLETE TYPE WITH STEEL PISTON

### OEM REFERENCE

MERITOR 202796

### CROSS REFERENCE

W01-358-8729, 202796, FLTA1R13130, GY 1R13-130, 1R132-130, 1T17BB-2



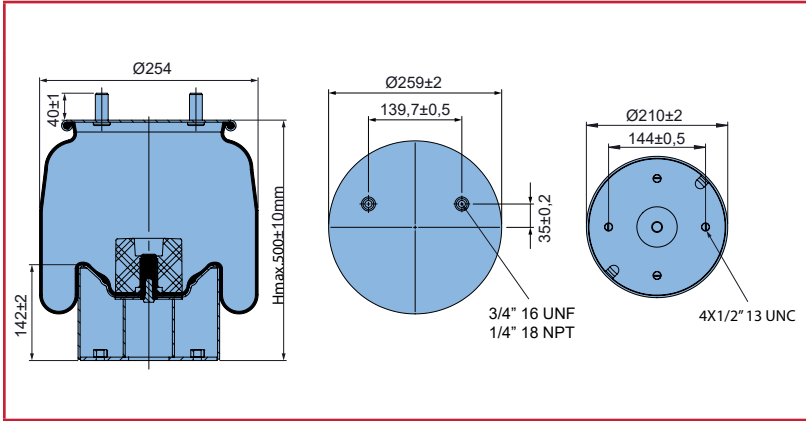

## PART NUMBER: 3827-8755

COMPLETE TYPE WITH STEEL PISTON

### OEM REFERENCE

HENDRICKSON TRAILER S21623, S22045, HK190T, PROTOTYPE C21623

### CROSS REFERENCE

AS8755, FLTA1R13124, W01-358-8755, 15S522, 10 10-15S522, 8522, S220451, 1R13-124

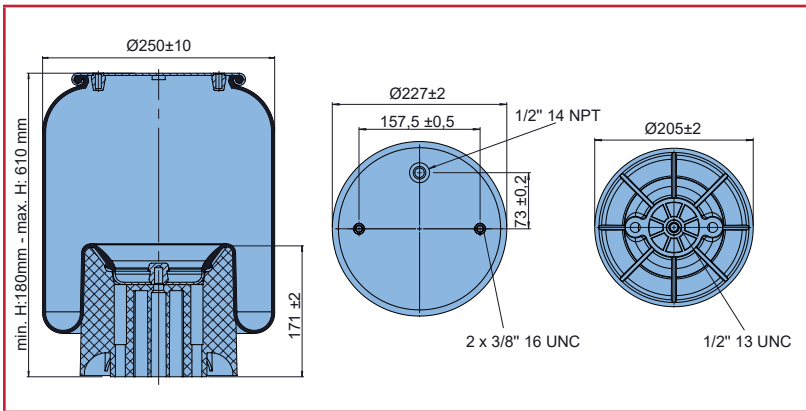

## PART NUMBER: 3827-8864

COMPLETE TYPE WITH PLASTIC PISTON

### OEM REFERENCE

HOLLAND (NEWAY) 90557173 (RL196A-12), HOLLAND (NEWAY) 90557223, BINKLEY NEWLITE (NS 190-16)

### CROSS REFERENCE

W01-358-8204, 90557173, 90557223, 8484, AS8204, FLTA1R12508, 1R12-522

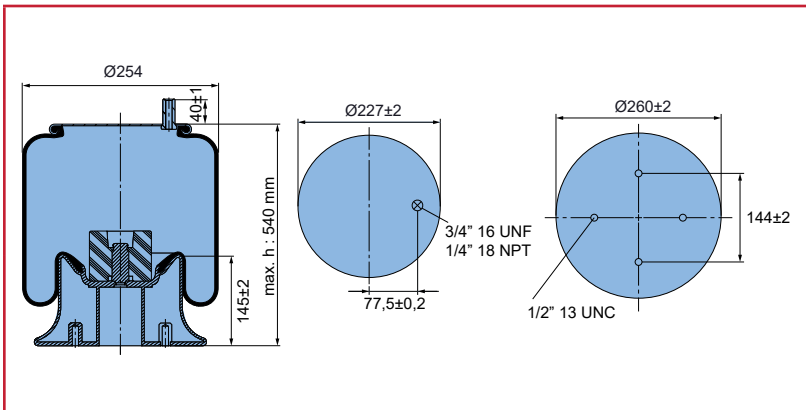

## PART NUMBER: 3827-9015

COMPLETE TYPE WITH STEEL PISTON

### OEM REFERENCE

HENDRICKSON TRAILER S21966 (HKA200 SPECIAL)

### CROSS REFERENCE

W01-358-8708, AS8708, FLTA1R13177, S21966, 8526, 10 10-16S526, 1R13-128, 1T17CA-6.5

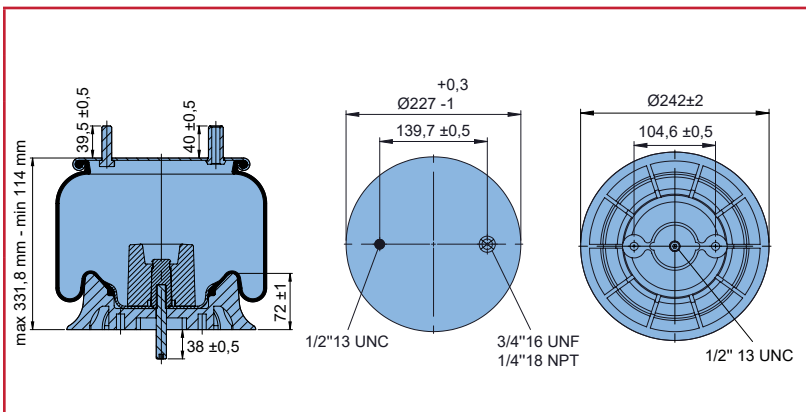

## PART NUMBER: 3827-9039

COMPLETE TYPE WITH STEEL PISTON

### OEM REFERENCE

HENDRICKSON TRAILER S2064/S11650, HOLLAND (NEWAY) 90557001, 90557023, 90557085, HUTCHENS H-9424-01 R & S BODY 1090218, RIDEWELL 1013589039C, FABTEK 101827, SUAER P50-734, WATSON & CHALIN AS-0012

### CROSS REFERENCE

W01-358-8091, AS8091, FLTA1R14171, S21784, 8523, 1R14-171, 1T19FC-6, S20901



# THE RIGHT FIT FOR THE ROAD AHEAD

## PART NUMBER: 3827-9069

### COMPLETE TYPE WITH PLASTIC PISTON

#### OEM REFERENCE

PETERBILT- 03-02456, 03-04759, 03-01649, 03-06746, 03-07112, 03-02038

#### CROSS REFERENCE

AS9069, FLTA1R12069, W01-358-9069, 03-07112, C81-1012, C81-6022, 8312, 1R12-069, 8312

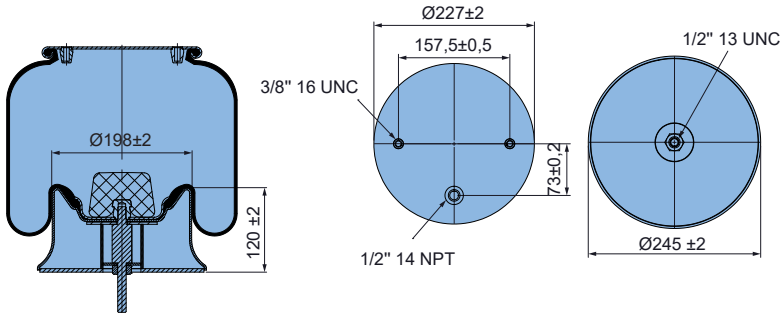

## PART NUMBER: 3827-9069HD

### COMPLETE TYPE WITH STEEL PISTON

#### OEM REFERENCE

PETERBILT- 03-02456, 03-04759, 03-01649, 03-06746, 03-07112, 03-02038

#### CROSS REFERENCE

AS9069, FLTA1R12069, W01-358-9069, 03-07112, C81-1012, C81-6022, 8312, 1R12-069, 8312

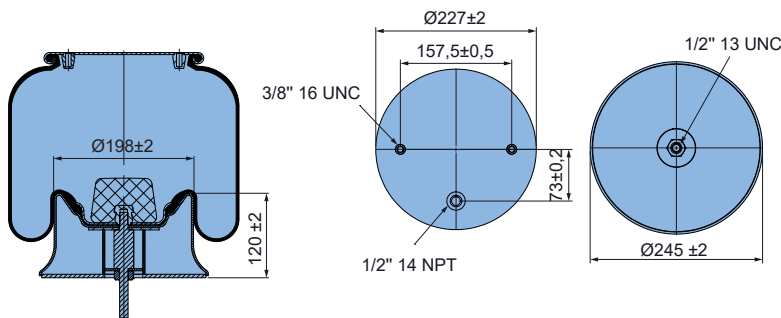

## PART NUMBER: 3827-9082

### COMPLETE TYPE WITH PLASTIC PISTON

#### OEM REFERENCE

HENDRICKSON CANADA S2066, S11651, B-12514-007, HUTCHENS H-9630-01, KWIK LOK/TODO (JIFFLOX) CP-5125, HOLLAND (NEWAY) 90557006, 90557027, 90557033 SPECIAL MOUNTING, 90557037, 90557054, 90557075, REYCO 12882-01, R & S TRUCK BODY 1090217, RIDEWELL 10035989082C, WATSON & CHALIN AS-0011

#### CROSS REFERENCE

AS8755, FLTA1R13124, W01-358-8755, 15S522, 10 10-15S522, 8522, S220451, 1R13-124

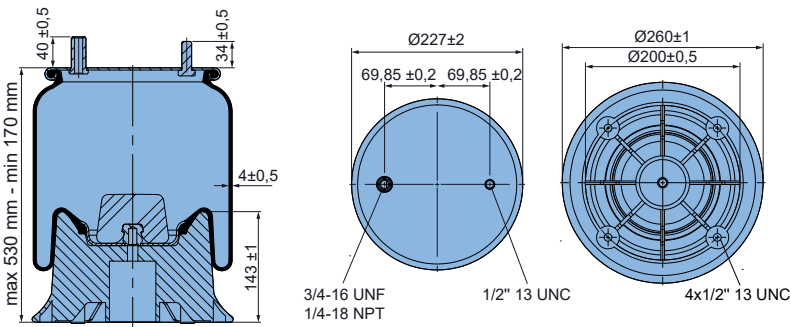

## PART NUMBER: 3827-9101

### COMPLETE TYPE WITH STEEL PISTON

#### OEM REFERENCE

HOLLAND (NEWAY) 905570089, 90557009, 90557082, RIDEWELL 1003589101C, REYCO 12883-01, SILENT DRIVE TRUCKWTELL 63647, MEF. SV.# NEWWAY 90044201, WATSON & CHALIN AS-0040

#### CROSS REFERENCE

AS9101, W01-358-9101, E-FS9101, 8315, 12883-01, 1R12-103, 1R12-113, 1R12-116

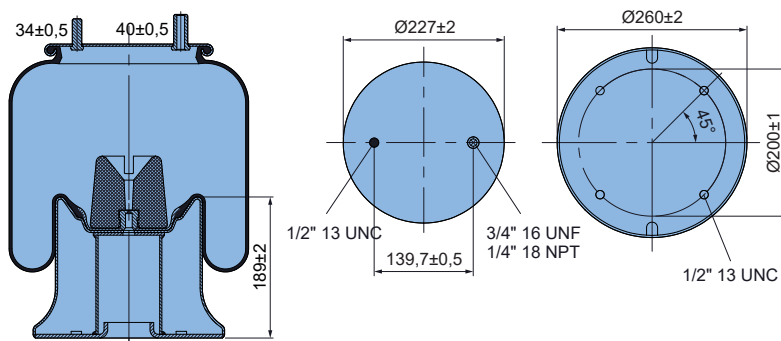

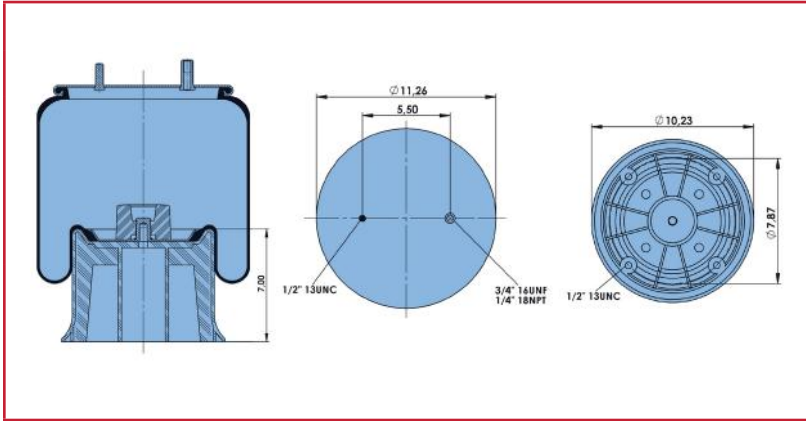

## PART NUMBER: 3827-9122

### COMPLETE TYPE WITH STEEL PISTON

#### OEM REFERENCE

HENDRICKSON TRAILER S3467, S3830, HOLLAND (NEWAY) 90557020, 90557071, 90557076, 90557077, HENDRICKSON CANADA B-12514-008, B12514-010, REYCO 12883-02, SAURER P50-732, RIDEWELL 1003589122C, WATSON & CHALIN AS-0023, HOLLAND (NEWAY) 90557185 (PARALLEL ALIGN)

#### CROSS REFERENCE

AS9122, W01-358-9122, 8313, FLTA1R13038, 566-26-3-072, 88912, 12883-02. 1R13-038, 1R14-045, 1R13-048, 1R14-060

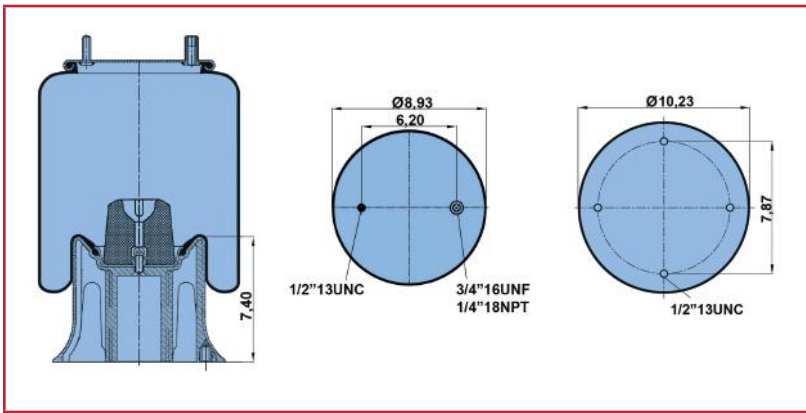

## PART NUMBER: 3827-9130

### COMPLETE TYPE WITH PLASTIC PISTON

#### OEM REFERENCE

HENDRICKSON TRAILER S20901 (INTRAUX 250), REUSE METAL DISK, HENDRICKSON TRAILER S21784 W/METAL DISK PISTON SUPPORT

#### CROSS REFERENCE

W01-358-8091, AS8091, FLTA1R14171, S21784, 8523, 1R14-171, 1T19FC-6, S20901

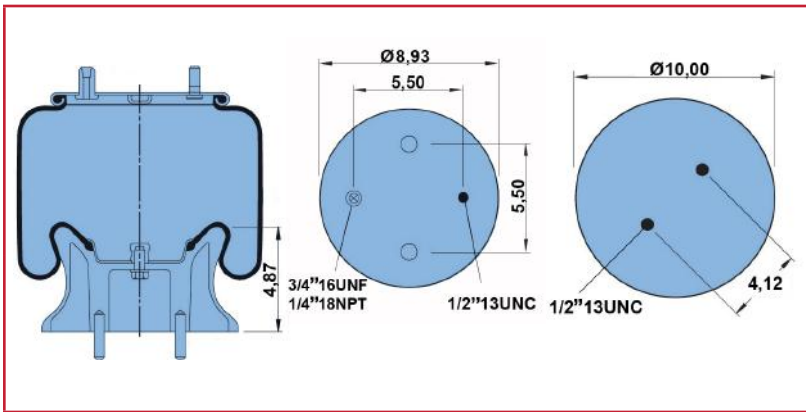

## PART NUMBER: 3827-9213

### COMPLETE TYPE WITH PLASTIC PISTON

#### OEM REFERENCE

NAVISTAR 501559C-1, 501559C-2, 1660581C-1

#### CROSS REFERENCE

AS9213, W01-358-9213, 9 10-16 P 441, 64308, W01-358-9241, 8407, 8441, 1T15M-6

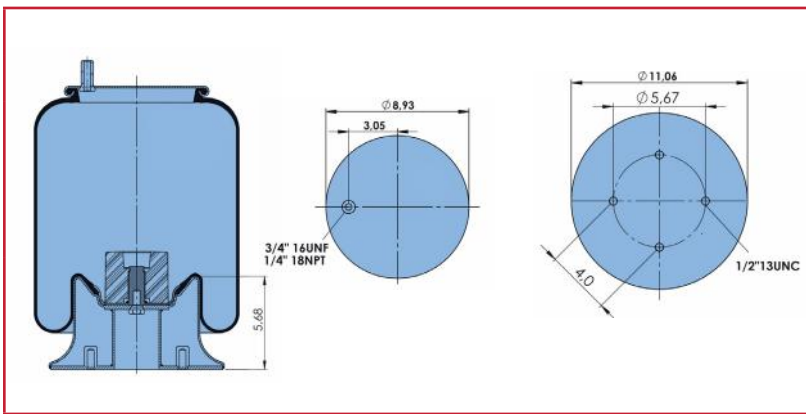

## PART NUMBER: 3827-9265

### COMPLETE TYPE WITH STEEL PISTON

#### OEM REFERENCE

HENDRICKSON TRAILER S202124, HT250T, C240413 (ROTATE PISTON 45 DEGREES) HT-250U, HT-250U-Y

#### CROSS REFERENCE

AS9265, E-FS9265, W01-358-9265, 9 10-19 P 435, 64288, 8435, E-F59265, 1R12-375



# THE RIGHT FIT FOR THE ROAD AHEAD

## PART NUMBER: 3827-9270

### COMPLETE TYPE WITH STEEL PISTON

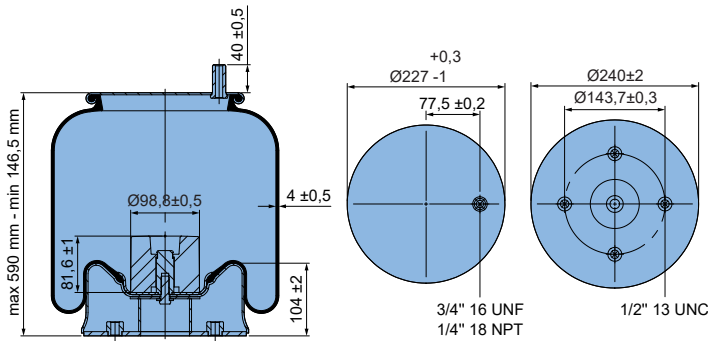

#### OEM REFERENCE

HENDRICKSON S-20010 (HT230T), S-21208, S-25559

#### CROSS REFERENCE

AS9270, FLTA1R13119, W01-358-9270, 64287, 8433, 9 10-13.55433, FS9270, 1R13-119, 1R13-0077, 1R13-102

## PART NUMBER: 3827-9293

### COMPLETE TYPE WITH STEEL PISTON

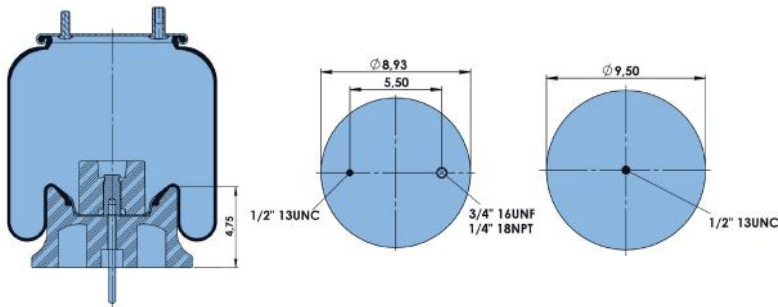

#### OEM REFERENCE

HOLLAND (NEWAY) 90557120, 1T15LP-5, NEWAY RL-196-14, RLK-196A-14

#### CROSS REFERENCE

AS9293, W01-358-9293, 99K15P424, 905-57-120, 8424, 1R11-912, 1R12-501

## PART NUMBER: 3827-9367

### COMPLETE TYPE WITH STEEL PISTON

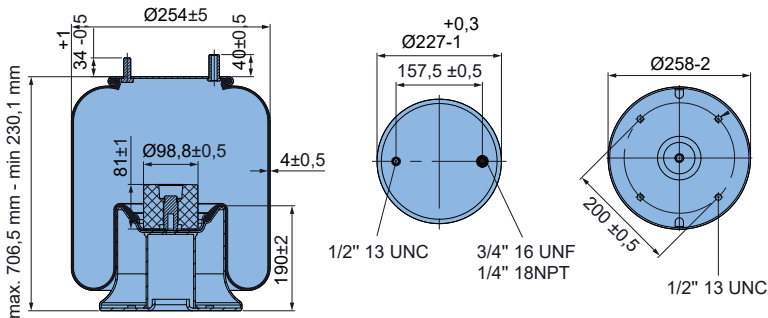

#### OEM REFERENCE

HENDRICKSON S14249, S4375

#### CROSS REFERENCE

AS93670, W01-358-9367, 9 10-21A505, CTT64716, 8505, 1R12-283

## PART NUMBER: 3827-9371

### COMPLETE TYPE WITH PLASTIC PISTON

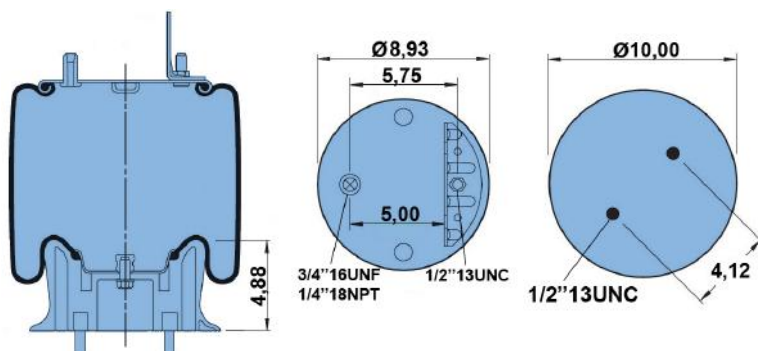

#### OEM REFERENCE

NAVISTAR 1670043C-1, 1686386C-1

#### CROSS REFERENCE

AS9371, W01-358-9371, 1670073C1, 1686386C1, 1R12-401, AS8521, 8521, 1S12-244



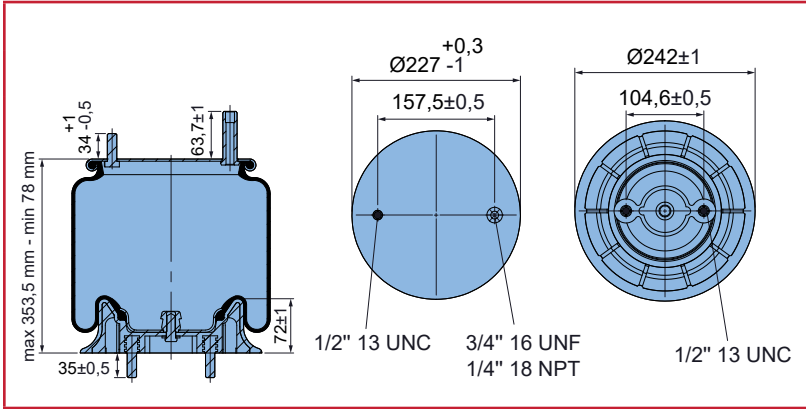

**PART NUMBER: 3827-9422**  
**COMPLETE TYPE WITH STEEL PISTON**

**OEM REFERENCE**  
 KENWORTH K303-6, K303-14, K303-15 (AIRGLIDE 100) OLDER VERSION WITH NO BRACKET

**CROSS REFERENCE**  
 AS9422, E-FS59422, FLTA1R11028, W01-358-9422 9 9-12R314, 8314, 1R11-028

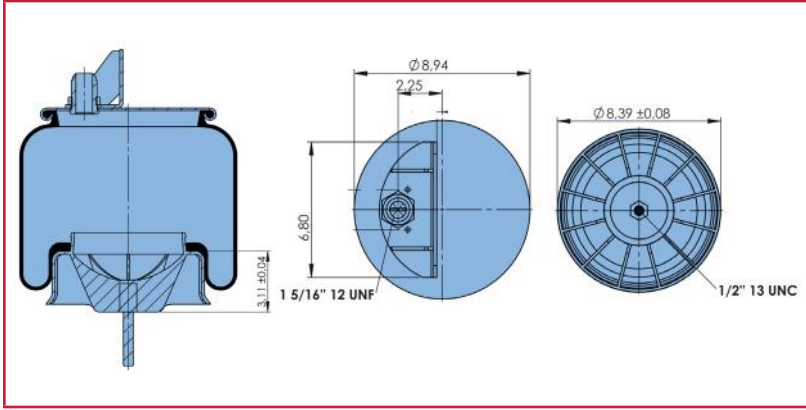

**PART NUMBER: 3827-9622**  
**COMPLETE TYPE WITH PLASTIC PISTON**

**OEM REFERENCE**  
 KENWORTH K-303-22 (AIRGLIDE 200 - 1998 - 5/05/2003) BRACKET 6049

**CROSS REFERENCE**  
 W01-358-9622, 452-9622, AS8740, 65367, 400357FB, 1R11-221

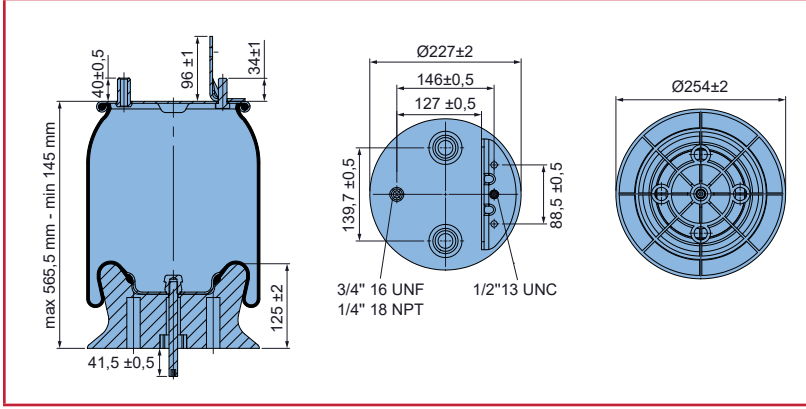

**PART NUMBER: 3827-9648**  
**COMPLETE TYPE WITH PLASTIC PISTON**

**OEM REFERENCE**  
 NAVISTAR 2027911C1 & 2027911C2, BRACKET 6047

**CROSS REFERENCE**  
 AS9648, W01-358-9648, 2027911C2, 81068, 9 10-18.5P456, 1R12-398

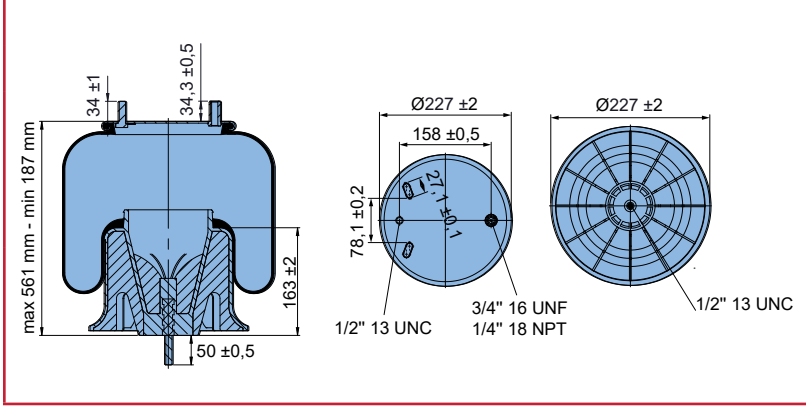

**PART NUMBER: 3827-9780**  
**COMPLETE TYPE WITH PLASTIC PISTON**

**OEM REFERENCE**  
 FREIGHTLINER 16-13810-000 (COMPOSITE), 16-13810-001, 16-13810-002, 681-320-0017, A16-124004-000, A16-14004-001, 1T15ZR-6

**CROSS REFERENCE**  
 AS9780, FLTA1R12303, W01-358-9780, 16-19769-000, 16-13810-000, 8382, 1R12-189, 1R12-303, 8382

- Bolt Or Stud
- Threaded Hole
- ⊗ Combination
- ⊗ Stud Air Inlet

# THE RIGHT FIT FOR THE ROAD AHEAD

## PART NUMBER: 3827-978 1

### COMPLETE TYPE WITH ALUMINUM PISTON

#### OEM REFERENCE

FREIGHTLINER A16-17574-001, A16-17574-002 (W/O BRACKET)  
681-320-0017 (ALUMINUM)

#### CROSS REFERENCE

AS8382, AS9781, FS9781, W01-358-9781, 16-13840-00, 16-19469-000,  
8382, 68-13200-017, 1R12-603

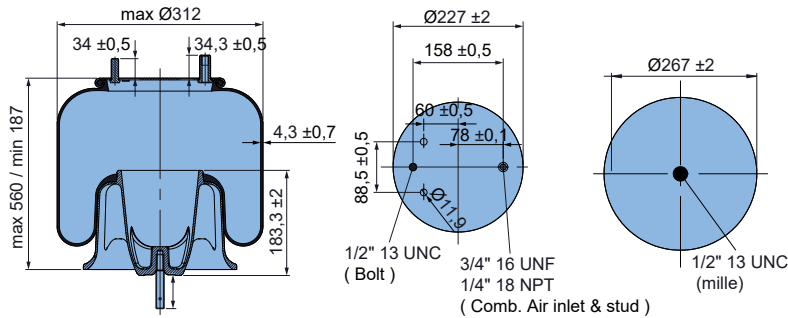

## PART NUMBER: 3827-9807

### COMPLETE TYPE WITH PLASTIC PISTON

#### OEM REFERENCE

HOLLAND 90557372, 50857000, CB-4000, 1T15M-2

#### CROSS REFERENCE

AS9807, W01-358-9807, 50857000, 90557372, 1R12-1047

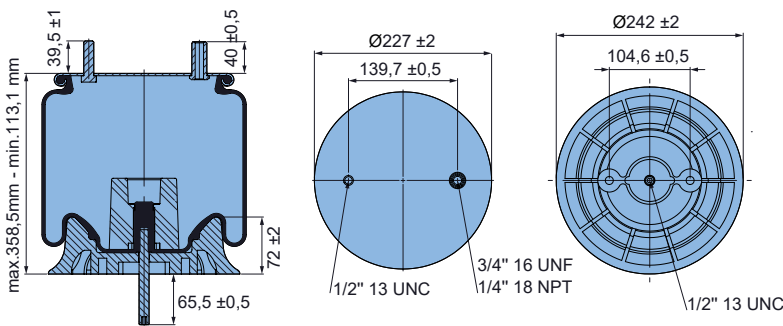

## PART NUMBER: 3827-981 1

### COMPLETE TYPE WITH ALUMINUM PISTON

#### OEM REFERENCE

ROWE TRUCK ASCC2000 RIDE

#### CROSS REFERENCE

AS9811, W01-358-9811, FSIW013589811

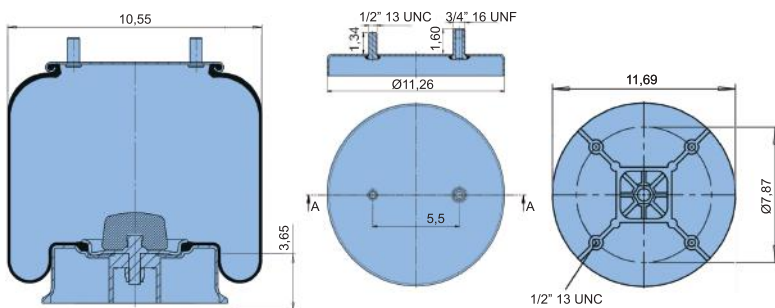

## PART NUMBER: 3827-992 1

### COMPLETE TYPE WITH PLASTIC PISTON

#### OEM REFERENCE

HOLLAND (NEWAY) 90557117 (AR92-12, AR92-14, AR93-14) WATSON &  
CHALIN AS-0090 SILENT DRIVE

#### CROSS REFERENCE

AS9921, W01-358-9921, 910175P443, 90557117, 8443

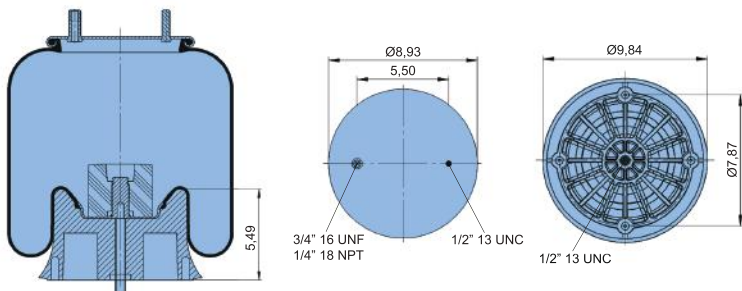

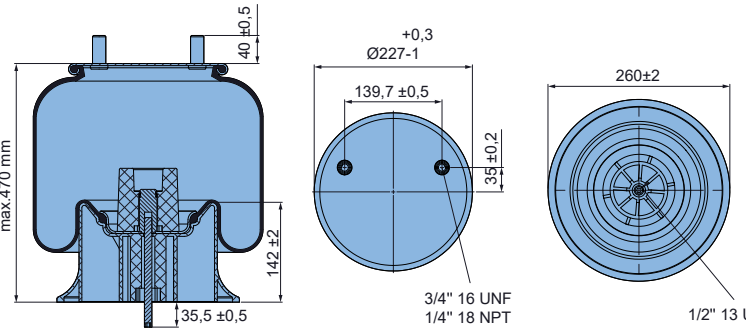

## PART NUMBER: 3827-9978

COMPLETE TYPE WITH PLASTIC PISTON

**OEM REFERENCE**  
HENDRICKSON S-28929

**CROSS REFERENCE**  
AS9978, W01-358-9978, S28929, AS8959

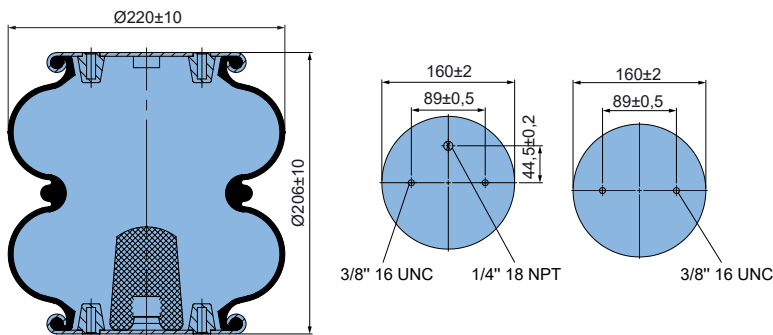

## PART NUMBER: 3827-6935

COMPLETE TYPE WITH STEEL PISTON

**OEM REFERENCE**  
HENDRICKSON TRAILER S14318, HLM LIFT NBAG HENDRICKSON  
AUS. 003318 (METRIC VERSION)

**CROSS REFERENCE**  
FD200-19310, W01-358-6902, W01-358-6935, 4310, AS4310, S2630,  
AS6902, 554784C1, 4848, 354-6902, 570-06-902

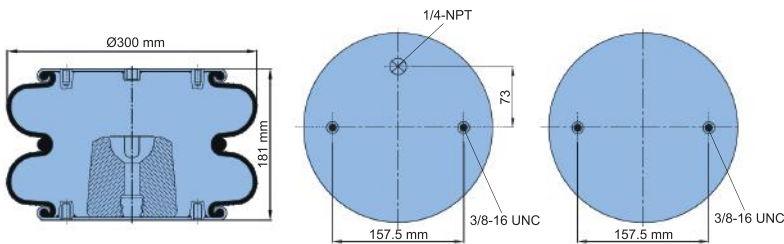

## PART NUMBER: 3827-7400

COMPLETE TYPE WITH STEEL PISTON

**OEM REFERENCE**  
FAB TEK 04-0080, FREIGHTLINER 16-10769-000, GMC 693230,  
HENDRICKSON TRAILER S1013, HOLLAND (NEWAY) 90557016, R & S  
TRUCK BODY 1027519, RIDEWELL 103587400C

**CROSS REFERENCE**  
2B12-309, AS4313, AS7400, W01-358-7400, 16-10769-000, FD 330-22 313,  
4313, 3130488, 90557016, 2B12-309, SP2822R-7400, 693230, 354-7400

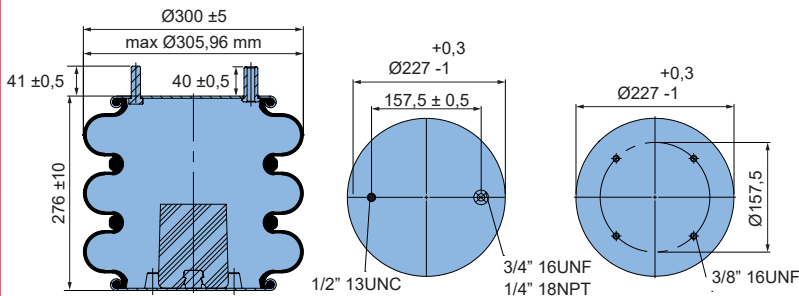

## PART NUMBER: 3827-8033

COMPLETE TYPE WITH STEEL PISTON

**OEM REFERENCE**  
APPLICATIONS: HENDRICKSON TRAILER S14487 (RIDE BAG) (PARALIFT  
ULTRA) (PARAREV) HENDRICKSON AUX. 003316 (METRIC VERSION)

**CROSS REFERENCE**  
W01-358-8033, B14487, 8446RB14487, AS8033, 3B12-312, AS4525,  
AS80330, FT330-29 525, 003316

# THE RIGHT FIT FOR THE ROAD AHEAD



## PART NUMBER: 3827-7036

COMPLETE TYPE WITH STEEL PISTON

### OEM REFERENCE

PETERBILT 29-03200 29-02454

### CROSS REFERENCE

ABSZ70-7036, SC29-Y036, W02 358 7036, 1S5-186, 579-10-1-083, AS PRSZ70 Y036 PR, AS7036, AS-5036, AS70360



## PART NUMBER: 3827-7206

COMPLETE TYPE WITH STEEL PISTON

### OEM REFERENCE

FREIGHTLINER 18-29919-000

### CROSS REFERENCE

ABSZ70-7206, SC31-W206, W02 358 7206, W02-358-7202, AS7206, 1S5-176, 579101115, AS7206, AS-5206, AS72060

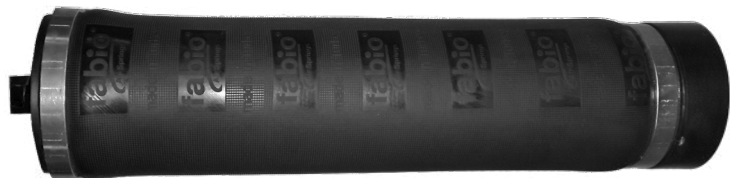

## PART NUMBER: 3827-7207

COMPLETE TYPE WITH STEEL PISTON

### OEM REFERENCE

FREIGHTLINER 18-52651-000, 18-40977-000, 18-66715-000

### CROSS REFERENCE

ABSZ70-7215, SC31-Y215, W023587215, W02 358 7207, AS7215, 1S5-175, 579101116, 947015-S, AS PRSZ75 Y215 PR, AS7215, AS-5215, AS72150



Bolt Or Stud



Threaded Hole



Combination



Stud Air Inlet







**Pennsylvania**

866.439.2329

[info@wheelerfleet.com](mailto:info@wheelerfleet.com)

[wheelerfleet.com](http://wheelerfleet.com)

**Texas**

800.786.2035

[customercare@wheelerfleet.com](mailto:customercare@wheelerfleet.com)