

# Oct 2017 <sup>Catch The Buzz™</sup> Bee Culture

The Magazine Of American Beekeeping

[www.BeeCulture.com](http://www.BeeCulture.com)



ROOT PUBLICATIONS \$4.99

# IS YOUR HIVE READY FOR WINTER?



MAKE SURE YOUR BEES GET THE NUTRITION NEEDED TO MAKE IT THROUGH THE WINTER

**POLLEN PATTIES - ENER-G- PLUS**  
**SUGAR SYRUP - POLLEN SUB**  
**NUTRITIONAL SUPPLEMENTS**  
*including Honey-B-Healthy*



FREE SHIPPING ON MOST ORDERS OVER \$150\* SOME RESTRICTIONS APPLY



**Brushy Mountain Bee Farm**  
*Serving Beekeepers the Best for 40 YEARS*

**BEST QUALITY | BEST SERVICE | BEST SUPPORT**

# KONA QUEEN HAWAII

Call Now to Reserve Your Order

Quality Italian & Carniolan Queens  
Available Through Thanksgiving

Be Prepared for Fall Requeening and  
Late Splits for Almond Pollination

Shipping Included on Orders of 100 or More  
Minimum Order of 12  
Live Delivery Guaranteed

*Not all Queens from Hawaii are the Same*



PO Box 768  
Captain Cook, HI 96704  
Phone: (808) 328-9016  
Fax: (808) 328-9460  
[www.konaqueen.com](http://www.konaqueen.com)

Bees Love   
**Global Patties**

You will too



Keep your hives strong and healthy with less effort and low cost  
Reduce winter loss and see faster spring build-up  
Help your bees thrive despite drought and stress from mites and disease

## Two North American Factory Locations

Plus depots across the U.S. and Canada to Serve You Best

BAY 2 - 8 East Lake Way NE, Airdrie Alberta T4A 2J3

Phone: 1-403-948-6084 - Fax: 1-403-948-6901

150 Parkmont West, Butte Montana 59701

Ph: 1-406-494-4488 - Fax: 1-406-494-3511

Call Us Toll Free in North America at 1-866-948-6084

We make protein and pollen patties to your specifications  
using only fresh, high quality, proven ingredients. Satisfaction guaranteed.

Be sure to visit our website

**[www.globalpatties.com](http://www.globalpatties.com)**

For our locations, news, ideas, specials, and much more...

Your bees will thank you

# ACORN™

BEEKEEPING EQUIPMENT

Ready  
Now For  
The 2017 Bee  
Season!

## The New Standard of Excellence in Plastic Frames and Foundations

Call Today!  
877-255-6078

info@acornbee.com www.acornbee.com

### Acorn One Piece Plastic Frames

- Flatter, Stiffer, Sturdier
- Redesigned  
Mega Strong Ears  
Last Forever
- 9-1/8" 6-1/4" Sizes



### Plastic Snap-in Foundations

- Fit well in  
9-1/8" and 6-1/4"  
Wood Frames
- Optional Breakaway  
Communication Hole



### Drone Combs

- Integrated Pest Management (IPM)
- Varroa mite control
- Queen Breeding
- 9-1/8" 6-1/4" Sizes



**Nick Lissaman**  
20 years experience

info@acornbee.com  
www.acornbee.com  
13818 Oaks Ave. Chino, Ca 91710

**MORE BROOD! - MORE BEES! - MORE HONEY!**



**EXCELLENT BEE ACCEPTANCE!**

Call Acorn Bee Today!  
877-255-6078





Visit our new website  
[www.hummerbee.com](http://www.hummerbee.com)  
to learn about all of our  
other available models:

Rough Terrain Forklifts

***XRT XL XT<sub>2WD</sub>***

The classic Hummerbee  
just got even better...

## ***TURBO II***

The Hummerbee Turbo is now more powerful, smoother, and faster than ever. Now featuring 56 hp being produced by a Tier 4 emissions compliant, Kohler turbo diesel engine. Diesel exhaust fluid is NOT required.

More power, a new maintenance - free articulation joint, easy to use joystick mast controls, digital gauge display, a quieter, redesigned transfer case, and the highest lift capacity in its class while being even more compact than before, make the Turbo II the most exciting Hummerbee yet.

# **A & O FORKLIFT**

[www.hummerbee.com](http://www.hummerbee.com)



Call A&O Forklift to order today  
800-943-8677

# Bee Culture

## October Features . . .

**THE NATIONAL** 24  
*England's National Honey Show beyond imagination.*  
 Val Rhenius

**COMMENTARY** 29  
*Killer Honey Bees in Arizona.*  
 Patrick Pynes

**INSTINCT VS. INTELLIGENCE** 39  
*The bee is the wisest and cleverest of all animals and the closest to man in intelligence.*  
 David Donnelly

**BEEKEEPING IN CENTRAL SOUTH CAROLINA** 43  
*Mild Winters, mites, cotton and soybeans.*  
 David MacFawn

**OBSERVATION HIVE HOW-TO** 46  
*From simple to complex, you can make these yourself.*  
 Claire Kimmel  
 Dan Long



Page 46

**TOP BAR PROTEIN** 60  
*Feeding pollen substitute as a patty in a top bar hive.*  
 Wyatt Mangum

**HONEY JUMBLES** 68  
*Nineteenth century cookies.*  
 Peter Sieling

**THE WALT TWO-FRAME HONEY EXTRACTOR** 81  
*Easy to make yourself with these instructions.*  
 Walt Dahlgren

**BUILD A CELL SHAPED DISPLAY** 85  
*A beautiful design with easy to follow instructions.*  
 Ed Simon



Page 68

**800.289.7668**

Executive Publisher – John Root

Associate Publisher, Senior Editor – Kim Flottum, Kim@BeeCulture.com, Ext. 3214

Assistant Editor, Design – Kathy Summers, Kathy@BeeCulture.com, Ext. 3215

Social Media, Event Specialist & Subscription Coordinator – Amanda DeSimone, Amanda@BeeCulture.com, Ext. 3255

Advertising – Jean Newcombe, JNewcombe@BeeCulture.com, Ext. 3216

**Contributors**

Clarence Collison • James E. Tew • Ann Harman • Kim Lehman • Phil Craft • Larry Connor  
 Connie Krochmal • Jessica Louque • Toni Burnham • Ross Conrad • Jennifer Berry • Ed Colby

POSTMASTER: Send address changes to  
 BEE CULTURE, The A.I. Root Co., 623 W. Liberty St., Medina, OH 44256

**Subscription Information**

U.S., one year, \$25; two years, \$48. Newsstand price: \$4.99. All other countries, (U.S. Currency only), \$20.00 per year additional for postage. Digital Edition \$15. Send remittance by money order, bank draft, express money order, or check or credit card. Bee Culture (ISSN 1071-3190), October 2017, Volume 145, Issue 10, is published monthly by The A.I. Root Co., 623 W. Liberty Street, Medina, OH 44256. Periodicals Postage Paid at Medina, OH and additional mailing offices.

Subscriptions, Book Orders – 800.289.7668, Ext. 3220 • www.BeeCulture.com • subscriptions@BeeCulture.com

Advertising – 800.289.7668, Ext. 3216; JNewcombe@BeeCulture.com

Published by The A.I. Root Co. Copyright© 2017. All rights reserved.



Cover – Get your full sheet of Pollinator Stamps at your local post office.



# New Store Opening

Riverside, CA



## Snap-in Foundations

- Stronger and Stiffer
- Used by Professional Beekeepers
- Lasts through years of extraction
- Uniform, perfect cells

*Pierco stands for American Quality!*



## Drone Frames

- IPM Method for Varroa mite control
- Perfect for Queen breeding



## Frames

- Increase honey production
- We use FDA food grade plastic resin
- High grade Beeswax coating

Visit our new website at:  
[www.Pierco.com](http://www.Pierco.com)

*Did you wait too long to order your frames and foundations? Is everyone out of stock now? Not Pierco®. We strive to serve you best by always having stock on hand. Give us a call and see what we can do for you today.*

- **New Products Available**
- **Huge Savings**
- **Order Now!**

**We Offer  
DOUBLE & TRIPLE  
WAX**



**Call Us!**

(800) 233-2662 | 680 Main St. | Riverside, CA | 92501



**We write over 88%  
of the Beekeepers  
in the program  
Nationwide.**



# **BEEKEEPING**

## **INSURANCE SERVICES**

### **APICULTURE INSURANCE PROGRAM**

**A Specialized Program for Beekeepers**

*Available Nationwide*

#### **Offering All Forms of Insurance Including:**

- \* **USDA Apiculture**
- \* **Property**
- \* **General Liability**
- \* **Automobile**
- \* **Life Insurance**
- \* **Home & Farm Insurance**

#### **We are Proud Members & Sponsors of:**

- \* **American Beekeeping Federation**
- \* **American Honey Producers Association**
- \* **California State Beekeepers Association**
- \* **Florida State Beekeepers Association**
- \* **Minnesota Honey Producers Association**
- \* **Montana State Beekeepers Association**
- \* **North Dakota Beekeepers Association**
- \* **Texas Beekeepers Association**

**Kevin Rader: [Buzzus@beekeepingins.com](mailto:Buzzus@beekeepingins.com)**

**[www.beekeepingins.com](http://www.beekeepingins.com)**

**888-537-7088**



# AHPA 49th Annual Convention & Tradeshow

January  
10-13,  
2018

Join us in 2018 in  
San Diego, CA at the  
4-star hotel,

**DoubleTree - Mission Valley!**



**American Honey  
Producers Association**

*For more information visit  
[www.AHPAnet.com](http://www.AHPAnet.com)*

# Bee Culture's Best . . .

## NEW FOR YOU 11

Hive Butler. Books – *Beekeeping. Inspiration and practical advice for beginners*; *VENOM. The secrets of nature's deadliest weapon*; *The Small Hive Beetle; Anatomy & Dissection of the honey bee*; *Mini Urban Beehive. A Sustainable Method of beekeeping*; *Beekeeping Tips and Techniques for the Southeast United States.*

## A CLOSER LOOK – PROTEINACEOUS

### LARVAL JELLY 35

Royal jelly is a part of the diet of honey bee larvae.  
*Clarence Collison*

### OXALIC. A BETTER WAY? 51

A new method may be better. Time will tell.  
*Jennifer Berry*

### BEEYARD THOUGHTS – OBSERVATIONS AND UPDATES 55

Queens – concerns from both my apiary and my wallet.  
*James E. Tew*

### NEONICOTINOID PESTICIDES: PART 1 64

A major problem for bees.  
*Ross Conrad*

## BEE KIDS' CORNER 70

All the buzz – for kids.  
*Kim Lehman*

## YOU MISSED IT! 73

Wherever you live in the U.S. there's a good meeting going on nearby sometime during the year.  
*Ann Harman*

## BIGGER PICTURE – BEE EQUIPMENT TAKE II 76

If you think you want quail one day you need to read this.  
*Jessica Louque*

## BOTTOM BOARD 96

A tale from the dark side.  
*Ed Colby*



Page 55

### In Every Month –

Honeycomb Hannah	9
<i>What's going on in the hive?</i>	
Mailbox	15
The Inner Cover	20
<i>Killing bees.</i>	
It's Summers Time!	23
<i>Travel, Fall and Goldenrod honey.</i>	
Honey Market Report	26
<i>Prices and weather.</i>	
Gleanings	89
Calendar	94

## HONEYCOMB HANNAH





# Kelley Beekeeping

SERVING THE BEEKEEPER SINCE 1924

## WINTERIZATION CHECKLIST



Winter Feeding— Winter Patties (Item No. 7709A)  
Patties packed with carbohydrates



Mice Prevention—Mouse Guards (Item No. 279-MG)  
20 gauge stainless steel guard with 3/8" punched holes



Accurate Ventilation and Moisture Control—  
Moisture Board (Item No. 9010, 9010-8)  
Absorbs moisture in the hive



Temperature—Hot Box (Item No. 9011A) Acts  
as an insulator. Bee Cozy (Item No. 9013, 9014)  
Provides a windbreak and protects the hive from  
freezing temperatures



Humidity Monitoring—Broodminder (Item No.  
9020) Checks the humidity level in the hive.  
Bluetooth Accessible



Nosema Prevention—Fumagilin B (Item No.  
96, 97, 98) Exclusive nosema treatment and  
preventative

Your hive needs  
60-100 pounds of  
honey to survive  
the winter

Moisture causes  
condensation which  
will drip onto the  
cluster causing a  
sudden drop in  
temperature

Poor ventilation  
causes mildewing  
and molding which  
can sour the honey  
causing nosema

Feed your bees  
until the first frost  
or until they quit  
taking feed.  
Whichever  
comes first

Be sure to check out our  
all-new, easier-to-shop website!  
Visit us at [kelleybees.com](http://kelleybees.com)!

**Order Now!**

[www.kelleybees.com](http://www.kelleybees.com)

1 (800) 233 2899

# New Item For Beekeepers & Some Good Fall & Winter Reading –

## The Hive Butler™

“Working, even when you’re not!”

Tired of precious honey frames in dirty supers, old coolers or cheap office totes? We sure were. Every time the frames stuck together or gashed each other open, we swore we’d make something better! Something designed just for holding frames securely – something food-grade. No more grass, paint chips, spider webs or bug parts. No more honey lost in a dirty cooler. Harvest equals joy, and profit. Beekeepers work hard – we wanted a better solution for our customers and for ourselves!

Today’s consumers, and beekeepers, will appreciate bringing the harvest home in a food-grade HDPE, BPA-free storage tote designed for beekeeping. The large notches hold the frames apart, so even the wonky or extra-wide ones will fit. Additionally, the lid secures the frames from the top.

The Hive Butler™ will hold up to eight deep frames. (We know deeps aren’t typically used for honey, but we often find deeps that need spun to make room for brood, and we knew we’d be frustrated if the box only held mediums.)

The Hive Butler™ is very heavy-duty and durable. The extra-large rim was designed in consideration of gloved hands. Carry it from any side, no sag or twist. Stackability was a priority as well. Even with an 80lb-max load, the Hive Butlers™ can be stacked up to four-high. No slip and slide, with the foot and deep lid well holding the stack securely.

The opacity of the box allows light in, which helps deter wax moths while you store your drawn comb in the off-season. (The Hive Butler™ is freezer safe.) Of course, we cannot guarantee that you’ll never have a wax moth, but the convenient zip tie holes, and large contact area between the rim of the box and lid will be a great deterrent to varmint large or small.

We knew the Hive Butler™ needed to work year around for custom-

ers, so we designed the lid to have an optional, removable center pane, to allow installation of a screen top for ventilation. Now you can use the Hive Butler™ in the beeyard!

Take it with you on your hive inspections – as you remove frames, stow them safely in the Hive Butler™, allowing the screen lid to keep everyone safe – (you and the bees!) If you save one queen from flying off or getting stepped on, you’ve paid for your Hive Butler™!

Need to make a split? We gave you 1.5” below the bottom of a deep frame, so you find a frame with a queen cell on the bottom, it can safely be transported to the new hive, or yard. Use those zip tie holes to secure your lid when moving bees on the frame.

Collecting a swarm? Carry the 8lb. HB with one hand up the ladder. Drop them in on drawn frames. The lid snaps securely and the frames aren’t going to slide as you head back down. No more heavy, slippery wooden ware on the ladder.

The Hive Butler™ will also make a great un-capping tub, and with the solid lid on, should solar melt your cappings in the hot sun. One commercial beekeeper told us he was going to use it as a scoop box, when making packages of bees.

Designed by beekeepers – for beekeepers, and produced entirely in the U.S.!

Hive Butlers™ will be available through our online store at [www.thehivebutler.com](http://www.thehivebutler.com) or our FB page!



*Bunches of Books this month*  
*Beekeeping. Inspiration and practical advice for beginners.* By Andrew Davies. Published by The National Trust Books, a registered UK Charity. Available at [www.pavilionbooks.com](http://www.pavilionbooks.com). ISBN 978-1-90988-198-3½” x 7½”, 95 pgs, hard cover, black and white and color drawings. \$12.95.



This is one of those little books you give to a friend who is thinking of taking up bees and doesn’t have a clue where to start. Yes, eventually a beginner’s class, an association and all the rest, but this is a good place to begin. Chapters include life in the hive, equipment needed, bee biology, inspections, managing bees, honey, problems (including *Varroa*), and the beekeeper’s year. The chapters are short but to the point, in an easy to read format, with good art, though not photos, to support the information. Got a friend who is thinking of bees? Give them a head start this Winter with this fine little book. – *Kim Flottum*

*VENOM. The secrets of nature’s deadliest weapon.* By Ronald Jenner and Eivind Undheim. Published by Smithsonian books, [www.smithsonianbooks.com](http://www.smithsonianbooks.com). ISBN 978-1-58834-454-0. 6¾” X 9”. 208 Pgs. Color throughout, soft cover. \$19.95.

VENOM will bring you face to face with some of the most dangerous creatures on the planet, including jellyfish, snakes, and wasps. It explores the difference between venom and poison and how each is used for predation, defense, competition and even communication. Fossil records and DNA traces venom back to its origin. And finally, it examines the relationships between these dangerous creatures and humans. And even using them to create new drugs, treatments, and vaccines. This is a definitive guide to this most deadly way of life. And it is, even with these excellent explanations, still the scariest book I’ve read. The very last chapter is on honey bee venom and how it works, and how people have made it work for us. Compared to



some animals, honey bees pale in comparison. Be very glad. – *Kim Flottum*

*The Small Hive Beetle, Aethina tumida Murray.* By Wm. Michael Hood, Prof. Emeritus, Clemson U. Published by Northern Bee Books, [www.northernbeebooks.co.uk](http://www.northernbeebooks.co.uk). ISBN 978-1-912271-07-8. 6½" X 9½", 139

Pgs, color throughout, soft cover. \$15.75.

The basics on this bee hive pest. Mike Hood did much of the ground work on this pest before he retired from Clemson, and has updated much of the information he presented in the first edition. Biology, history, importance, and most importantly (and easily 90% of the book, control. This includes preventing, cultural practices, monitoring, genetic control, mechanical control, physical control, biological control and finally chemical controls. He finishes with the Top 20 Small Hive Beetle Management Recommendations. For some this is a pest to deal with on and ongoing basis, and this is the book for you. Check it out.

*Kim Flottum*

*Anatomy & Dissection of the honey bee.* H. A. Dade. Published by Northern Bee Books and The International Bee Research Association. ISBN 978-0-86098-280-7. 196 pgs., black and white line drawings. Soft cover. Available at bookstores and Amazon, for \$37.

This reprint of the original 1962 classic is still the basis of teaching beekeepers the structure

of the honey bee in part 1, and how to dissect one to expose all the components of this amazing insect in part 2. The drawings are accurate and superb and easy to use. Additions include the changes in technology in microscopes up to a point, and techniques in dissecting soft tissues. But if dissection is part of what you want to be doing, this is a good reference, and it includes hundreds of other references for you to check. – *Kim Flottum*

*Mini Urban Beehive. A Sustainable Method of beekeeping.* Albert Chubak. Published by EcoBeeBox. [www.ecobeebox.com](http://www.ecobeebox.com). ISBN 978-0-692-91865-4. 8½" X 11", 40 pgs., color throughout. \$24.95.

This isn't a typical book. It's more of an occasional magazine in format, but it has book-like information, and, magazine like articles, and, no advertising. It defies description. There will be more in this series, and they will be similar in size, content and scope, but they will cost much less. If you like the first one, and you will, the rest are easy to get, see below, and should probably be in you collection. Nevertheless, it has a focus and a good discussion on a lot of beekeeping application. The author lets the science to the scientists, and shares from that what it takes to do well with bees. It starts with lots of history of bee hives, and small hives in particular. This hive, named the Mini Urban Beehive, or MUB, is the focus here, after the history and other information. It has information on setting up one of these smaller hives, and using any one of nine techniques to do so, ranging from swarms, packages, splits, joining colonies and more. There are notes from users on how they coped with these hives and bees, what to look for when inspecting a MUB, different configurations of the four-box hive, contacts in every state, good neighbor beekeeping, types of bees, forage, propolis, using the observation windows to best advantage, feeding, using the foundationless frames, the Eco Bee Box Bracket, which holds everything together, wintering – this list goes on and on. Each topic briefly explained in the context of using these small hives. It has a useful glossary at the end. You can find out more about these hives, and this book at [www.ecobeebox.com](http://www.ecobeebox.com). – *Kim Flottum*



*Beekeeping Tips and Techniques for the Southeast United States, and, Beekeeping Finance.* David MacFawn. Published by Outskirtspress, Inc. [www.outskirtspress.com/bookstore](http://www.outskirtspress.com/bookstore). ISBN 978-1-478-79057-0. 6" x 9", 145 pgs., color throughout, soft cover. \$24.95.

Covering a topic seldom covered, beekeeping in the south, and the southeast to boot, this new release touches on a wide variety of topics, both fundamental and very advanced, most of us that live above the Mason/Dixon line either don't know about, or don't care about. And it's about time. It tends to be a bit random, but at the end, you've covered everything you wanted covered. It's a lot like having a beer with a beekeeper you just met and he's sharing what he know, kind of like it just came to mind. However, the season guide brings it all together. And it adds a level almost nobody deals with, and that's the finance side of running a bee operation, even though it is a bit SE centric. Basically, honey bee management must support honey bee biology, and then weighed for financial efficiency. Things you don't at first think of – like how much does it cost to build a honey house? Competition with foreign beekeepers is small margin business, and every penny counts. Are farm markets worth the time? And, decisions that cost money, rather than make money count. There is a lot of spread sheet analyses of entire beekeeping operations to learn from, and better, to use, to make good biology, and good financial decisions. Beekeepers mostly don't do this, and mostly, they should. Try it.

*Kim Flottum*





# Attractive Honey Containers Make the Sale

Check out our website or catalog for other types and sizes of quality honey containers!

### Glass Skep Jars



### Muth Jars



### Honey Bears



2 oz.  
Clear Bear  
w/Snap Cap



### Hex Jars



### Inverted Plastic Jars



### 3 lb. Plastic Jar with Hexagon



### Queenline Glass Honey Jars



### Classic Plastic Honey Jars



### 3 lb. Glass Round Jars (Quarts)



DADANT  
WEBSITE



[www.dadant.com](http://www.dadant.com)

DADANT®  
DADANT.COM



51 S. SECOND STREET, HAMILTON IL 62341 • PHONE (217) 847-3324 • FAX (217) 847-3660 • TOLL FREE 1-888-922-1293  
• CHICO, CA (877) 332-3268 • FRESNO, CA (877) 432-3268 • PARIS, TX (877) 632-3268 • SIOUX CITY, IA (877) 732-3268  
• WATERTOWN, WI (877) 232-3268 • ALBION, MI (877) 932-3268 • WAVERLY, NY (877) 532-3268  
• CHATHAM, VA (800) 220-8325 • FRANKFORT, KY (888) 932-3268 • HIGH SPRINGS, FL (877) 832-3268



# NAKED BEE HIVES

**Now available!**

**Full line of Western Cedar and Pine  
beekeeping supplies:**

- **Boxes**
- **Bottom Boards**
- **Lids & Covers**
- **Frames**
- **Foundations**
- **Accessories**
- ***and more to come!***



**[www.NakedBeeHives.com](http://www.NakedBeeHives.com)**

**800-459-8718 • Portland, OR • a division of LWO Corp.**

## Eclipse

Probably no surprise here, but still fun to watch. Watching the eclipse with four hives in our viewing area. Vancouver, WA so the Portland, OR area advertised as 99% sun obscuration. Bees remained active until almost the height of the eclipse then someone sounded the alarm and everyone headed home; all inbound and no outbound flights for approximately 10 minutes then back to normal.

One more item of entertainment to augment an already memorable event.

Enjoyed your escapades working in your garage (a couple of issues ago); thought you based the article on a hidden camera in MY garage. Scary.

Bill Blazer  
Vancouver, WA

## Christmas Gift Idea!

Are you stumped what to give friends and family for Christmas?

Those gift cards have no snap?  
Shopping exhausting?

Act with purpose, beekeeping community!

Purchase 20 sheets of Protect Pollinator USPS stamps to tuck into 20 Christmas Cards/Thank-you Notes. SEE THE COVER!

Bring attention to the need to protect pollinators. Bees, Butterflies!

John Miller  
Gackle, ND

## Super Lifter

This photo shows a device that I constructed out of some old farm implements (a cultivator and a peavey), a little steel plate and some welding. Its purpose is to allow two people to lift a heavy



super together. Sometimes this is a matter of height but usually the difficulty is when a hive body is used as a super. They can weigh 100 pounds. I call my device "The Super Lifter."

Jeff Dirlam  
Winchester, CT

**Editor's Note:** *This basic design has been around for years, with slight modifications on materials and designs. I've had a similar, though much less robust model hanging in my garage for over 20 years. I am continually amazed at both the inventiveness of beekeepers and how practical their applications are to what they have to do.*

## Stop Robbing In Minutes

Three years ago, in desperation, robbers attacking a hive that had gone queenless, I ran and got an entrance reducer, not good enough solution, then propped an extra lid I had on hand while I ran to get a robber screen. When I returned the situation had fixed itself.

The robbers who were focused on the hive entrance but it had disappeared. They would approach the hive and fly right up the front over the lid. The hive's bees started to scent the air and call their bees to come around the corner. I did leave the entrance reducer in place. Robbers didn't want to enter the shaded area created by the lid. I left the lid in place for the rest of the season. I tried taking it off a week later, robbers showed up, I put the lid back, robbers left.

Last year I put the lid in place for new packages being established near strong existing hives.

This year I used the lids with packages that I was feeding as sometimes that can attract neighboring hives. No problems.

Now the yellowjacket numbers are growing. They are waiting for any dead bee being thrown off the landing board. It is only a matter of time when they try to enter the hives.

I wanted to focus their attention away from the landing boards so I propped the lids in front of each hive. I also put a small piece of brick at the ends of each hive to

# Bee Culture

623 West Liberty St.  
Medina, OH 44256  
mailbox@beeculture.com



prevent any wasp from sneaking in at the ends. At first the foragers came to a stop and hovered upon their return. Then a few crawled along the lid edges and came down the hive and into the hive. These girls were soon scenting the foragers the new way until they started to fly right in. A day later all were with the program. Wasps are not hovering out front of the hive and do not venture under the cover. They do come up to the yellowjacket traps in good numbers.

I hope this technique can help someone.

Colleen Howe-Gregory  
Friday Harbor, WA



**Bee Culture Calendar  
Photo Contest:  
Beeyards At Sunset  
Send Photo, Contact  
Info and Calendar in  
Subject Line to  
Kim@Beeculture.com  
HURRY!**



# FORMICPRO

FOR TREATMENT OF VARROOSIS  
CAUSED BY VARROA DESTRUCTOR IN HONEY BEES (APIS MELLIFERA)

## Protect your Bees with the all new Formic Pro™

It is highly recommended to monitor phoretic mite levels monthly during periods of brood rearing and treat when local thresholds are reached. Treat during the colony population increase phase to protect the bees going into the honey flow. Treat during the colony decrease phase to protect the bees that will make up the winter cluster. In warmer climates additional treatments may be necessary due to longer brood rearing time. Missed treatments can lead to excessive varroa loads and may require more than one treatment.



**14 DAY**  
2 STRIPS  
APPLIED ONCE

APPLY 2 STRIPS  
AT DAY+0 FOR 14  
DAYS.



**20 DAY**  
1 STRIP  
APPLIED TWICE

APPLY 1 STRIP AT  
DAY+0 FOR 10 DAYS.  
REMOVE AND RE-  
PLACE WITH A SEC-  
OND SINGLE STRIP  
FOR AN ADDITIONAL  
10 DAYS.

DAYTIME TEMPERATURES HIGHS NEED TO BE BETWEEN  
50°F AND 85°F DURING THE FIRST 3 DAYS OF TREATMENT.

*From Nature, to Nurture.*

Now available in the USA through your beekeeping supply company  
866-483-2929|613-398-8422|www.nodglobal.com|info@nodglobal.com





## It's All About The Smell

Upon reading Jay Evans article in the August issue of *Bee Culture*, I have to respond.

In his first paragraph he stated that bees often choose murky water over pristine ones. The reason is simple. It's the odor that causes this. Let me explain. When bees find a source of nectar, pollen, a new home site, etc. they have to recruit other hive mates to this spot. This is done with the dance and odor. Without odor they would have a tough time.

I think pristine water would be lacking in odor so there would be no recruitment. He cites several studies that seem to confirm his thought, but could it be that we're over thinking a simple answer?

As long as I'm on the topic of odor. I would like to give my thoughts on swarm lures. They do attract swarms that are in the air, but I don't think they have any attraction on nest scouts unless there are old combs in the decoy. Let me explain.

When scouts pick a new home site, they return to the cluster and start the buzz run then lead the flying bees to the new site by means of a scent trail. You could have 30,000 bees that have no idea where they new home is, so if this swarm flies close to a hive that has a swarm lure the 30,000 bees will go here. It's the same smell the scouts are leading the swarm with.

Jim Cowan  
Aberdeen, WA

*Fake Quotes Will  
Ruin The Internet*  
*Benjamin Franklin*

**FOR ALL YOUR PROCESSING NEEDS**

**MAXANT**  
HONEY PROCESSING EQUIPMENT

AMERICAN MADE IN OUR NEW FACTORY  
**978-772-BEES**  
[www.MaxantIndustries.com](http://www.MaxantIndustries.com)

3100 EXTRACTOR  
MADE IN THE USA

2017 Empire State Honey Producers Association, Inc.

# ESHPA Fall Meeting

November 16, 2017 - November 18, 2017  
2017 Theme: *North x Northeast*

Sheraton On The Falls Hotel  
In Niagara Falls, Canada

To Register visit [ESHPA.org](http://ESHPA.org)

**Our Speakers Include:**

<b>Michele Colopy</b> Pollinator Stewardship Council	<b>Dr. Christian Krupke</b> Purdue University
<b>Dr. Rob Currie</b> University Of Manitoba	<b>Dr. Nigel Raine</b> University Of Guelph
<b>Dr. Scott McArt</b> Cornell University	<b>Emma Mullen</b> Cornell University
<b>Dr. Valérie Fournier</b> Université Laval	<b>Dr. Jonathan Lundgren</b> Blue Dasher Farms
<b>Les Eccles</b> Ontario Tech-Transfer Team Lead	<b>Paul Kozak</b> Provincial Apiarist Ontario

**Main Highlights Of This Year's Meeting:**

- 2 FULL days of Beekeeping Presentations
- 2017 Beekeeper of the Year Award
- Banquet & Live Auction Friday Evening
- Honey & Mead Contest - \$2000 in Cash Prizes!
- Thursday Optional Bus Tour - Pick one:  
1. Parker Apiaries 2. Mead Workshop or 3. Beekeeping 101

Visit our website for special rate on your hotel room at [www.ESHPA.org](http://www.ESHPA.org)

**OBA**  
ONTARIO BEEKEEPERS' ASSOCIATION  
Since 1881

This year's meeting is with the Ontario Beekeepers' Association as a Joint Meeting!

# Project Apis m.

Your “go-to” non-profit honey bee research organization, with programs in the USA & Canada

*PAm is dedicated to enhancing the health of honey bees while improving crop and honey production.*



PAm has infused over \$6 million to support honey bee health since 2006:

- \* Funded BIP Tech Transfer Teams
- \* Produced BMPs
- \* Scholarships for PhD students
- \* Expanding forage resources
- \* Invested in new technologies
- \* Discovered new pathogens
- \* Supporting long term stock improvement, bee germplasm preservation, new Varroa controls

*You can help support PAm*  
[www.ProjectApism.org](http://www.ProjectApism.org)

Project Apis m.

## Seeds for honeybee habitat



[ernstseed.com](http://ernstseed.com)  
[sales@ernstseed.com](mailto:sales@ernstseed.com)  
 800-873-3321



# MANY FACETS ONE ABF



JANUARY 9-13, 2018  
 GRAND SIERRA RESORT - RENO, NV  
[ABFCONFERENCE.COM](http://ABFCONFERENCE.COM)

## BEE ONE WITH US!

Discover the many facets of the ABF at the 2018 American Beekeeping Federation Conference & Tradeshow in Reno, Nevada. Join us, as we celebrate our 75th Diamond Anniversary with four days of spectacular educational sessions, networking and fun.



**SUGAR BRICKS**  
 "Convenient in every way"  
 A year-round feeding strategy that reduces starvation and increases overwinter success.  
 Eliminates the mess of syrup



3 1/2 lbs of feed per brick (approx. 6" x 6" x 2")  
 Set of 12 bricks: **\$93** (Delivered in U.S.)  
 Send checks payable to: Mel Disselkoen  
 Apiaries, 1941 Alba, Wyoming, WY 82409  
[www.mdasplitter.com](http://www.mdasplitter.com)  
 INTERNATIONAL MATING NUC, INC. © 2010



**Sailor  
Plastics**  
[sailorplastics.com](http://sailorplastics.com)  
 1-800-380-7429

*Visit our website  
for all of your  
bottling needs!*

**Subscribe Today!**  
 Visit us online at: [www.farmingmagazine.net](http://www.farmingmagazine.net)



A Quarterly Publication  
 1 year - \$18 (4 issues)  
 Canadian subscribers: \$24  
 2 years - \$32 (8 issues)  
 Canadian subscribers: \$45

Payment by mail check or Money order to:  
 Farming Magazine  
 PO Box 85  
 Mt. Hope, OH 44660

**FARMING MAGAZINE**  
 "The Magazine that offers hope to the small Farmer"

**Trees For Bees**  
**FALL NURSERY SALE**  
**Bee Club Special**  
**Pick Up Only**  
 Visit Webpage or Call  
 For Details

 [www.rockbridgetrees.com](http://www.rockbridgetrees.com)  
 Bethpage, TN • 615.841.3664  
[www.rockbridgetrees.com](http://www.rockbridgetrees.com)

**REGISTER NOW**  
**ABFCONFERENCE.COM**

**2018 AMERICAN BEEKEEPING FEDERATION  
 CONFERENCE & TRADESHOW**

**SHINE BRIGHT IN RENO!**

- Hear from experts, trendsetters & influencers
- Learn best practices
- Shop a tradeshow packed with beekeeping innovations
- Showcase your skills in the 2018 Honey Show
- Have next-generation fun at the Kids and Bees event
- Network with 900+ fellow beekeepers

**75th Anniversary**  
**ABF CONFERENCE & TRADESHOW**

**HAVE A GRAND TIME!**

Fun for the whole family:  
 The Grand Sierra Resort is home to Fun Quest, the largest arcade in northern Nevada, as well as two laser tag arenas, a bounce house, climbing apparatus, Grand Adventure Land Park, and even a 50-lane bowling center.



Send us a Sample  
 1 lb. Sample of Choice  
 1.00 (Retail \$2.00)

**Candace Moss**  
 Country Buyer  
 5000 South 2000 East  
[cmoss@barkmanhoney.com](mailto:cmoss@barkmanhoney.com)

**Landon Shaw**  
 Country Buyer  
 5000 South 2000 East  
[lsaw@barkmanhoney.com](mailto:lsaw@barkmanhoney.com)

Buying honey from all parts of the U. S.

**Barkman  
Honey**





# INNER COVER

In case you haven't noticed, Africanized honey bees have not gone away, have not gone back to Africa or Mexico, nor have they surrendered to the European Honey Bee Police and given up. They are still out there and still killing people when the opportunity comes up.

There are several things worth noting that are, as near as I can figure, more right than not that should accompany that first statement. The first is that beekeeping in the areas that are, or are suspected to be host-

ing African and Africanized bees has not gone away either. The second is that beekeepers in those areas, or at least some of them, tell me that the bees in their boxes are not the banshees from heck that will kill you in a heartbeat if they even suspect there's a threat to home and hearth. Rather, they are working with – either normal European honey bees produced by a queen from some place other than where these bees normally reside, or, and this is the interesting note, the bees they have are a – take your pick – hybrid of the more docile European and nasty African bee that is not nearly as defensive as one side of its heritage is, or as gentle as the other side of that mating, because they are something in between and they are more manageable than not. And, they are quick to point out, the true-to-life meanies, or the 'selected-for-gentle-but-still-Africans', and even the hybrids mostly all laugh at any issues with *Varroa* mites.

In fact, some of these good people routinely take me to task for not advocating that queen producers should be using the traits that reside in AHBs that allow them to resist, no, allow them to laugh at *Varroa*. And I'm not the only one they chastise. Pretty much anybody who isn't keeping these bees is, by some standards, harboring second rate bees, keeping bees that need coddling, and are chemically dependent for both *Varroa* control and feeding. So there. Most of these folks, you have probably guessed, are on the treatment free side of the coin. Preferring bees that have managed to survive their local conditions without medications and without having to be fed, and sourced from local suppliers, cutouts and feral colonies. There are quite a few folks who make this work for them.

But what brought this to my attention was an email from somebody who is in this group that resides in the SW part of the country, where the bees that aren't sourced from someone outside that area have some level of AHB blood in them. The mixed breed isn't harsh enough to be unmanageable so beekeepers are content to use this local stock.

But the fact that there are still feral bees in the area that do have the worst of the worst behaviors, and routinely take control of hives that aren't AHB led, and that can and will defend a feral nest with the ferocity commonly assumed for Killer Bees remains. This is undisputed. Not common, but viable. I've included a map showing about where these bees are and will be relative to vegetation and climate in the southern U.S. and parts of the west coast.

And Killer Bees got the attention of at least three people in August in the SW. And they died. Two of these people were overwhelmed by thousands and thousands of defending bees, and one died because of allergy. But the bees were African, or Africanized. It still happens. It doesn't make the national news anymore because it's old news. And it's not common. And that it happened again was because it was more than likely the person's fault, not the bee's. It will still make the local paper, often below the fold or even inside, but it will be there, with all the gruesome details. I really can't imagine what that experience can be like. Not even close.

Most of these states, probably all of them have made available information on dealing with a Killer Bee finding and what to do if attacked. The Uni-

versity of Arizona provides the eight point information sheet next to the map and it is typical, and good. But I don't think I've ever heard of anybody being killed by running into the road and being struck by a car, which is something I would not have thought of. So I learned something today.

So what brought all this up, he says finally, is that I was recently in a position where a colony had to be controlled, right now. Not tomorrow, or next week. Not even later today. Now. The first thought that went through my head was the information I got from the Florida Inspectors on how to do this in an emergency. Their advice, because they encounter these bees on occasion, is to always have a very large lawn leaf litter bag or three in your apiary all the time, stuck under a colony or somewhere so it's handy when you need it. And when you need it, you grab the bag, put it over the colony all the way to the bottom where the entrance is, tip the colony over, and tie the bag shut. That keeps the bees in immediately, and the heat from the Florida sun will kill the colony in minutes. A most perfect solution. Well, the bees seldom think so, but if you save a life that's what counts. But it is a terrible loss because these colonies are seldom weak, diseased or in trouble. They tend to be strong, big and healthy. What a loss. What a shame.

Anyway, we weren't in possession of a bag so we had to make it up as we went along. Years ago we did a video on how to handle honey bee emergencies for fire departments. It's been used for years and is still pretty much accurate, though technology has upgraded fire trucks and fire truck chemistry so they do things somewhat differently now. But the sure-fire way to stop a beehive then, and still, is to soak the bees with cold soapy water. And that's what we did.

We had a good garden sprayer with lots of pressure and a wide angle nozzle that delivered quite an amazing amount of liquid when en-

## Killing Bees.

gaged. We suited up, two smokers lit, sprayer pumped and five gallon pails almost filled with cold soapy water and headed out. They met us, oh, probably 30 yards from the hive, bouncing off suits and veils like a hailstorm. We moved fast and got to the colony before it got too riled up and smoked the heck out of the front, driving everybody back in then closed it tight. Meanwhile I popped the top and inner cover and as soon as the front was closed dumped those two five gallon pails of cold soapy water down between every frame and slammed the top down hard and fast. As I was dumping the bees in the air were being sprayed, and, to quote the article I wrote the first time I had to do this, flying bees, when sprayed, dropped like cold, wet stones. Dead before they hit the ground.

We waited about 10 minutes, enough time to get two more pails, and did it again, nearly filling the bottom deep again. Then we moved the top box, sprayed anything moving on top bars or between frames, did the second and finished with the bottom box. We bagged up the boxes and removed them from the crime scene.

But it was daytime, and there were bees in the air, and bees far from home and bees stunned but not dead, and in a couple of hours they returned, calmed down and came to and soon realized home was no longer where it had been. Nothing remained except the wet bodies of thousands of sisters, a muddy spot, and the smell of death. So they gathered together, a grouping of, oh, maybe a pound of bees and clung to each other hanging on a tree limb that overhung the killing field. When it was dark we went out to finish them and they were still in a mood, waiting until we got very close and with only veils we paid the price of revenge, but in a few minutes finished off the rest. All gone but a few stragglers, bewildered and lost.

I share this not because I'm proud of having to do this, or succeeding, but because it's a skill set you should have. Moving a nasty colony to a location where they will not harm people is always good and then requeening it so you get to keep the bees is the first best choice. But when lives are threatened people will look to you as the beekeeper and

assume you know what to do. Now you do.

•

The University of Arizona provides the following information regarding bee stings.

All wild honey bees in Arizona are presumed to be Africanized.

If you encounter a hive or swarm, assume they are Africanized honey bees and do the following:

1. Do not panic! Seven out of 10 deaths related to bee attacks (not involving bee allergy incidents) are due to folks panicking and literally causing their own death by running off cliffs, in front of cars, drowning, etc. Being hit by cars and drowning are the two most common tragedies.
2. Do not try to remove a colony yourself! Call the experts. Though their venom is no more or less toxic, the Africanized bee tends to sting in greater numbers and is more easily provoked than the European honey bee.
3. If you are being chased, run away in a straight line and find shelter inside a car, house, or building. Africanized bees are slow fliers and most healthy people can out run them. If you cannot access

shelter, run the length of two football fields, before stopping.

4. Avoid other people, or they will also be attacked. Once stung, you are a "marked" target. Bee stings are delivered with a pheromone which labels you as a threat and incites other defensive bees to sting.
5. Scrape stings off as soon as you get to an indoor safe place. Wash the sting site with soap and water, apply a topical antibiotic, and ice wrapped in a cloth will help soothe the discomfort.
6. Never dive underwater. The swarm will simply wait for you to surface, and your head and face will be the first to emerge.
7. Seek medical attention in case of anaphylactic shock. Symptoms occur within seconds or minutes may include: difficulty breathing, difficulty swallowing, dry cough, turning pale, itchy rash, itching and swelling of the eye area, wheezing, rapid or weak pulse, anxiety, fainting, dizziness, hives, etc.
8. If an adult sustains more than 30 stings, they should be treated in a hospital emergency room.

Be careful out there!

*Eve Joffe*



This map shows AHB habitat suitability from a recent logistic regression model that is based on state collected AHB occurrence data (blue points) and both bioclimatic and remotely sensed vegetation data. In both this logistic and a similar Maxent model, the major influential variables include: Frost days, percent tree cover (VCF), mean temp of driest quarter, mean temp of wettest quarter, range in Enhanced Vegetation Index (EVI), and precipitation event size. The eastern spread of the Africanized bee from western Louisiana has been delayed, possibly due to major differences in honey bee forage and phenology in the mesic forests.



*Healthy Hives, Stronger Bees*

# NATURAL POLLEN — HAS MET — ITS MATCH

Scientifically developed to provide the best bee nutrition, Ultra Bee has been shown to match natural pollen's results in the field. Give your bees the nutrition they deserve - feed them Ultra Bee.

- USA ingredients only
- FDA certified
- Highest protein content available
- Balanced amino acid profile
- Pre-made Patties ready to use, just place on top bars

### FD-374 Ultra Bee Patties 10 lb box

10 lb box ..... \$34.95

### FD-374 Ultra Bee Patties 40 lb box

1-3 boxes ..... \$85.95

4-10 boxes..... \$80.95

11-39 boxes ..... \$74.95

40+ boxes..... \$69.95

### FD-376 Ultra Bee Patties

Bulk Pack 2100 lb...\$3,295.95



**MANN LAKE**  
WE KNOW BEES

**800-880-7694**  
[www.mannlake.com](http://www.mannlake.com)

\*Free shipping applies to most orders over \$100 sent standard service within the lower 48 states. Prices are subject to change without notice.

# It's Summers Time –

## Travel, Fall and Goldenrod Honey

It's hard to believe that Summer is essentially over. As I write this it's the end of August, so we have a few more weeks, but everything is starting to show the signs of Fall coming on. The kids are all back in school, the county fair has come and gone and next weekend is Labor Day weekend. We've harvested our Summer crop of honey – got about 300 pounds from five or six hives. We're still getting the fresh vegetables from the garden, but it's slowing down already.

Fall in Northeast Ohio can be really beautiful depending on how much rain we've had and how quickly the weather changes. Right now we're sitting in Asheville, NC at the Mother Earth Beekeeping Institute where Kim is helping teach new beekeepers. The crepe myrtles (a beautiful plant that doesn't grow in Ohio unfortunately) are blooming and it's sunny and warm here.

There are about 130 folks here in Asheville taking two days out of their busy life to learn how to be better beekeepers. This is always so encouraging, to see new people hungry for the right kind of knowledge. This weekend they got four experts – Kim, Jennifer Berry, Steve Repasky and Shane Gebauer. Beekeeping is alive and well.

One thing we like to do at the end of our beginning beekeeping classes is a honey tasting. We did one here in Asheville. It is always fun to see new beekeepers realize that there is a lot of difference in honeys.

We've started doing more than just tasting honey. We do some pairings with cheese and fruit. One thing that is really fun to do is to have a jar of Buckwheat honey and dark chocolate. Buckwheat honey is very strong and I don't particularly like the taste of it. But when you dip dark chocolate in it something wonderful happens. If you're teaching a class or maybe at one of your monthly meetings do a honey tasting. It's a lot of fun.

It's been a blur since I wrote the previous paragraphs. We had a pleasant Labor Day weekend – hope you did too. Here in Northeast Ohio the leaves are just starting to turn and the nights are a little cooler. Fall is definitely nearby. The garden is winding down. It's the time when you've got more tomatoes and peppers and zucchini coming on than you can handle yourself, so we share a lot.

We spent a few days in northern California last week at the WAS – Western Apicultural Society – 40<sup>th</sup> Annual Conference. The weather was beautiful, bordering on too warm the day we arrived – 92°.

The meeting was held on the campus of the UC Davis. We were close enough to walk back and forth to our hotel. Davis is known for it's bicycles – lots and lots of bicycles. There are many roads that are completely blocked to car traffic. We saw lots of students riding their bikes. The bike racks took up almost as much space as the parking lots for cars. And of course beautiful plants all around. It was hot the whole time we were there. They've been setting records for heat out there all Summer.

Meanwhile back home the chickens were well taken care of by Jessica, Kim's daughter who has moved back to Ohio. She has really done a good job of helping with the chickens, the garden and the cats. It's a joy to have

her here with us.

The young chickens have finally started to lay. So at first you get those small little eggs, but it doesn't take long before you're getting regular sized eggs. We now have enough eggs to share again.

Since the addition to the coop this past year we have two distinct 'rooms'. For a few weeks now all but one of the chickens are in the old part of the coop at night when it's time to shut the door. One of the two-year old girls has taken to going into the other new area and perching on the open window all by herself. She sits looking out the window facing away from the other room where all of the other chickens are. It's very odd. The first night she did this I couldn't see her because it was dark. So I counted 19 chickens about three times, went outside to check the pen, then finally found her in the other part of the coop. I guess she just wants to have her own space.

Just last night (early September) we stepped out on our front porch, where we have one nuc hive, and smelled the faint aroma of goldenrod honey being processed by the bees. Tonight Jessica asked me if I had been on the front porch and was there a chance that something had died underneath the porch. I said, smiling, no that's goldenrod honey.

It's a very odd smell the first time you experience it. Once you know what it is it's quite pleasant and refreshing to know that they are bringing in food that will get them through the Winter. The honey is wonderful – well Kim and I think it's wonderful. It doesn't taste anything like it smells.

Our Fall is shaping up to be as busy as the Summer has been. Next weekend is our 'Voices of *Bee Culture*' event here in Medina. Mid October is Kim's 'Hardest Season' class. In late October we are scheduled to go to London for one more visit to the National Honey Show. So we keep dancing as fast as we can and enjoying every minute of it.

We extend our thoughts, concern and prayers to all of the folks who have suffered during the two hurricanes that hit Texas and Florida. I have family and friends in both states, but as far as I know they are all safe with only minor things to deal with. Our own John Root and his wife, Elisabeth live in Sarasota and were able to weather the storm without any major damage or loss.

I hope you enjoy your Fall and are preparing your bees for Winter. Let's hope it's a mild one this year.



**Bee Culture Calendar Photo Contest:  
Beeyards At Sunset  
Send One Photo/Email to  
Kim@Beeculture.com  
with Calendar in the subject line and  
contact info in the email.**

# The National

Val Rhenius

## England's National Honey Show Beyond Imagination

Throughout its history, the National Honey Show has been held at various venues in and around London. 2007 was the last time the National Honey Show was held at the RAF Museum in Hendon in northwest London <https://www.rafmuseum.org.uk/london/>. That year, the show offered a program of eight lectures. It was also the first year that workshops were held, limited to twelve attendees, held within the trade hall, one each day, on the preparation of exhibits for show purposes.

The RAF Museum was quite a popular venue with the additional interest of the museum next door. The security was tight, access time restrictive but on the whole our years there were a great success.

However there came the time to move to a larger venue and a large public school a little further west became our home for the next eight years. St Georges College was available to hire only during school holidays so the Show moved to the last weekend in October. Facilities included a larger room for lectures, which were in later years moved to a tiered lecture



**The 86th  
Honey Show**

**With Beekeeping  
Workshops**

26th - 28th



**Sandhurst**  
Portsmouth Road,  
www.honeyshow.org.uk

# h National y Show

eping Lectures,  
and Trade Hall

n October 2017



own Park  
Esher, Surrey KT10 9RT

neyshow.co.uk

hall seating around 250. As the years went by even this hall became too small with standing room only. The school also offered classrooms, so we were able to expand the workshop program. Our workshop program now has six or seven parallel workshops each morning and afternoon of the show on topics additional to the preparation of exhibits from beekeeping exam preparation to beeswax modelling etc. After a year or two, the trade side of the show became too big and moved to a gymnasium in a separate building about 100 yards from the lectures, workshops and the canteen. Our luck with the weather in all those years meant we somehow avoided a dampened show despite the time of year.

During the St Georges Years two parallel sets of lectures were introduced, taking place in the smaller room where we had originally started our main lectures. On Friday, *Bee Craft* magazine sponsored and organised a series of lectures on their work by more newly qualified researchers. Then in response to requests, a series of Saturday lectures on a more practical level for newer beekeepers was introduced.

In 2014 a venture to video our main lectures was introduced. One of the London beekeepers was a professional news cameraman and his team produced the first set of videos available for the world to view on the National Honey Show YouTube Channel. These have proved so popular that we plan to continue this service into the future, to which end we need help. If you watch and enjoy our lecture videos, any donation, any currency, will be gratefully put towards our educational program <https://mydonate.bt.com/charities/thenationalhoneyshow>.

New competitive entry classes over these last few years have included a commercial honey beer class, additional honey classes, microscopy classes, National Trust Classes (open to apiaries sited on National Trust Properties [www.nationaltrust.org.uk/](http://www.nationaltrust.org.uk/)) and last year a class for a skep made from traditional materials.

In 2015 the weather in the UK must have been exceptional for the bees. We had such a high number of entries that the staging team had a huge challenge as to how and where to display them all. We had to turn traders away for lack of space . . . and it became overwhelmingly obvious that we had outgrown the venue.

So in 2016 we moved to Sandown Park Racecourse in west London. It is conveniently situated for the south and west of England and for Heathrow Airport. There is good access, accommodation nearby, ample parking, and with everything under one roof, no excuse to stay home if it rains. The venue has a good mobile signal, wifi, several lecture theatres seating around 400 – but if you miss one of our main lectures, there is the opportunity to catch up on YouTube from your armchair later. There are additional quiet rooms for workshops. The trade hall, canteen and competitive are all in the same hall. There is space for the array of skeps in the competitive class, new for 2016. We are delighted to be returning to Sandown Park in October 2017, 2018 and we hope, a long time into the future.

Looking back, the National Honey Show even with its long history, has grown almost beyond recognition over the last 10 years. Visitors look forward to the event each year, its vibrant atmosphere makes it a great place to browse, catch up with the latest scientific news and to meet and chat with friends old and new.

The National Honey Show is a UK based, self financing, registered charity. All are welcome to visit, there is a very reasonable admission fee, or you can become a member by registering on line. <http://www.honeyshow.co.uk>

We hope to see you here this month. **BC**



October 2017



BEE CULTURE

# OCTOBER - REGIONAL HONEY PRICE REPORT

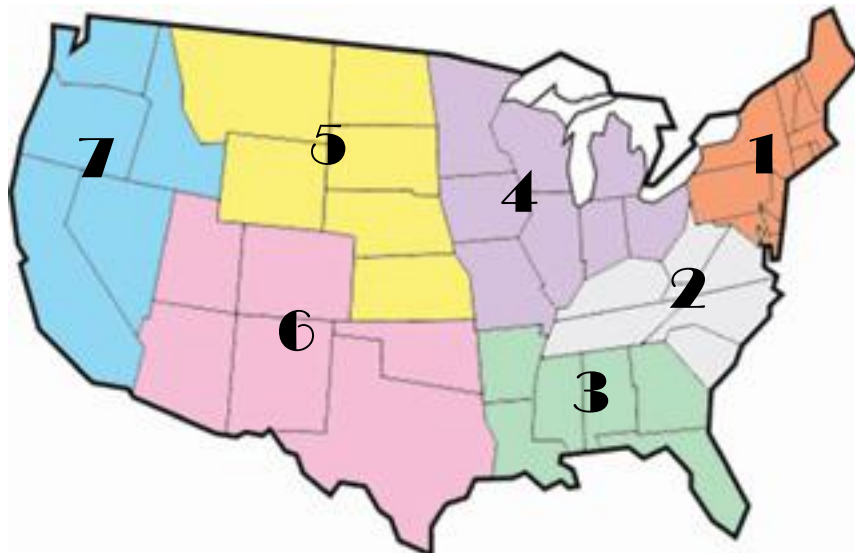

## Prices and Weather

The evolution of the U.S. beekeeping industry continues unabated, though at glacial speed. Very inexpensive, and by most counts illegally imported honey is slowly gutting the U.S. honey industry on the commodity scale, but, importantly, actually helping on the local level. Imports from several countries have increased dramatically in the past couple of years, while the lack of honey imports from China remains the elephant in the room, or should we say beeyard. At the same time, weather has been the beekeeper's worst enemy this season

with too much rain in some places and far too little in the breadbasket where most of our crop is made each season.

So, we went to our reporters and asked about prices, the weather and some management efforts that will help some of these issues. Here's what we found out.

Overall, 34% of our reporters (primarily our smaller scale reporters) plan to raise prices this year, 59% will remain the same, and only 7% (pretty much our commercial reporters) will lower prices to compete. Regions 1, 2 & 3 are mostly steady, while 4 & 5 are a bit more

aggressive in increasing prices.

Producing less honey and more of something else is always an option, so we asked if that was in the cards next year. Overall, fully 63% said status quo, no change, but 2% will increase pollination, 21% are raising more nucs and queens, while 14% will actually increase honey production to meet local demand.

Then we switched to the weather. Rain was mostly the only topic, with an interesting split. 25% too much, 50% about right, 25% too little. Regions 5, 6 & 7 on the lower side, the rest of us split all over the map. It will be interesting to see how NASS

honey production reports later this season reflect this. Big picture, 41% will have a reduced crop, the rest average or a bit above. A couple of caveats here. The survey was, perhaps, a bit too early to grasp final numbers, and, no single region was all up, or all down. Time will tell here, as will NASS.

Summer weather will dictate some management chores, too. 70% will be Fall feeding with carbs, 29% with protein, 37% will be combining their colonies to take their winter losses in the Fall (I wonder how either NASS or BIP figure those numbers?), and 57% will be double checking queens before Winter really sets in.

REPORTING REGIONS										SUMMARY			History	
	1	2	3	4	5	6	7	Range	Avg.	\$/lb	Last Month	Last Year		
<b>EXTRACTED HONEY PRICES SOLD BULK TO PACKERS OR PROCESSORS</b>														
55 Gal. Drum, Light	1.88	2.12	2.33	2.18	2.08	2.18	2.08	1.50-2.50	2.16	2.16	2.22	2.27		
55 Gal. Drum, Ambr	1.80	1.98	2.19	2.26	2.06	2.07	2.06	1.35-2.70	2.09	2.09	2.12	2.12		
60# Light (retail)	205.00	182.25	198.33	223.75	192.45	174.94	180.00	129.00-250.00	195.40	3.26	208.53	205.81		
60# Amber (retail)	203.50	201.83	191.67	194.33	203.16	171.62	180.00	129.00-300.00	191.82	3.20	200.72	202.48		
<b>WHOLESALE PRICES SOLD TO STORES OR DISTRIBUTORS IN CASE LOTS</b>														
1/2# 24/case	95.78	74.60	88.80	67.50	87.68	84.00	87.68	60.00-121.20	84.76	7.06	87.32	83.08		
1# 24/case	131.61	107.23	137.69	110.91	148.00	128.78	128.40	86.40-192.00	126.27	5.26	128.69	124.28		
2# 12/case	119.23	95.88	115.27	95.87	120.11	100.80	114.00	70.00-192.00	109.22	4.55	112.74	110.67		
12.oz. Plas. 24/cs	105.38	87.25	82.00	83.86	91.51	107.00	97.20	30.00-148.00	94.03	5.22	101.06	99.08		
5# 6/case	144.56	106.00	154.35	105.25	134.14	136.00	134.14	71.50-210.00	127.53	4.25	127.95	129.45		
Quarts 12/case	198.86	134.88	129.00	165.05	185.00	135.08	132.00	109.20-275.00	153.10	4.25	152.12	149.32		
Pints 12/case	117.74	86.25	86.20	109.00	111.00	75.73	84.00	65.00-168.00	96.02	5.33	93.22	91.94		
<b>RETAIL SHELF PRICES</b>														
1/2#	5.96	4.15	4.70	4.47	5.00	3.84	5.40	2.68-9.00	4.96	9.92	4.74	4.55		
12 oz. Plastic	7.36	4.59	5.68	4.77	5.00	6.50	5.73	3.79-12.00	5.80	7.74	5.84	5.83		
1# Glass/Plastic	8.26	6.73	7.65	6.26	7.50	6.50	8.00	3.00-14.00	7.37	7.37	7.39	7.20		
2# Glass/Plastic	14.27	11.37	12.60	10.28	10.00	9.00	14.00	4.79-21.00	12.40	6.20	12.60	12.35		
Pint	13.99	9.11	9.24	12.30	9.33	9.65	8.40	6.00-18.90	10.17	6.78	10.45	9.84		
Quart	20.06	15.63	17.64	16.20	16.33	16.11	19.10	8.50-32.00	17.31	5.77	17.04	16.75		
5# Glass/Plastic	30.24	26.00	37.13	23.67	26.00	20.63	28.64	15.00-43.50	28.03	5.61	26.99	26.80		
1# Cream	10.62	8.85	11.25	8.12	16.00	5.50	9.00	5.50-16.00	9.91	9.91	9.29	8.86		
1# Cut Comb	14.56	9.38	8.33	11.10	10.00	6.50	14.00	5.00-24.00	11.59	11.59	11.54	10.75		
Ross Round	9.99	6.65	20.00	10.83	11.68	10.50	8.40	6.00-20.00	10.36	13.81	9.56	8.94		
Wholesale Wax (Lt)	9.75	5.08	5.80	5.48	7.61	5.00	6.00	3.00-15.00	6.21	-	5.94	6.16		
Wholesale Wax (Dk)	10.50	4.72	5.00	4.95	6.28	4.50	5.00	2.00-12.00	5.56	-	5.39	5.58		
Pollination Fee/Col.	96.00	60.00	68.33	77.50	80.00	95.00	95.00	30.00-150.00	80.00	-	87.58	79.12		

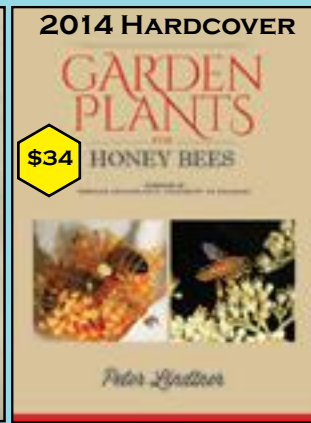

# WICWAS QUALITY BEE BOOKS

Prices include postage within the USA. Request quote for international orders.

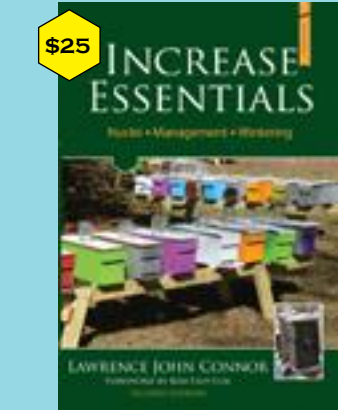
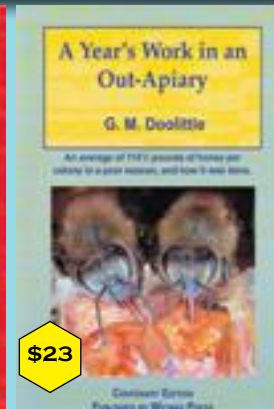

**ON LINE PAYPAL STORE:**  
[WWW.WICWAS.COM](http://WWW.WICWAS.COM)

**MAIL ORDERS:**  
 WICWAS PRESS, 1620 MILLER RD,  
 KALAMAZOO, MI 49001





HERE AT DADANT WE PRIDE OURSELVES ON PRODUCING TOP OF THE LINE HONEY BEE FEEDS TO FORTIFY COLONY HEALTH AND BUILD RESISTANCE TO THE PROBLEMS PREVALENT IN TODAY'S APIARIES.



AP23 Winter Patties are a high carbohydrate feed for honeybee colonies light on stores during the winter months. Contains Sugar, AP23, and Honey-B-Healthy.

- Can be used in winter and early spring in place of Candy Boards
- Readily accepted by the bees
- Convenient for all beekeepers

**M0016010PHW** –  
Ctn/ 10 patties **\$22.80**

**M0016040PHW** –  
Ctn/ 40 pounds  
1 - 9 **\$49.50**  
10 - 35 **\$48.00**  
36 + **Call**

## AP23® Pollen Substitute

AP23® is a high protein feed developed for all levels of beekeepers. It helps maintain colony strength by boosting populations, which result in better crop pollination and honey crops.

### PATTIES

**M0016010PH** – Ctn/ 10 patties

1 - 3 **\$24.95**  
4 - 10 **\$22.95**  
11 + **\$20.20**

**M0016040PH** – Ctn/ 40 pounds

1 - 20 **\$69.85**  
21 - 39 **\$67.85**  
40 - 159 **\$64.10**  
160 + **\$58.85**

**M001601500** – 1 tote **\$2,100.00**

### DRY FEED

**M0016005** – 5 lb bag

1 - 10 **\$19.95 ea.**  
11 + **\$19.50 ea.**

**M0016040** – 40 lb bag

1 - 3 **\$75.95 ea.**  
4 - 10 **\$72.75 ea.**  
11 - 39 **\$68.75 ea.**  
40 - 159 **\$66.35 ea.**  
160 + **\$63.50 ea.**



FEED **AP23** FOR A  
HEALTHY BEE!

## Brood Builder Pollen Substitute

### PATTIES

**M0014610H** – with Honey-B-Healthy  
**\$19.75 / 10 pack**

**M0014640H** – with Honey-B-Healthy

40 lb. box  
1 - 20 ctns **\$53.35**  
21 - 39 ctns **\$52.35**  
40 - 159 ctns **\$50.35**  
160 + **\$48.35**

**M0014640HHN** –  
with Honey-B-Healthy & Nozevit  
**\$73.60 / 40 lb. box**

### DRY FEED –

**M0014625** – 25 lb bag  
1 - 5 **\$39.50 ea.**  
6 - 10 **\$37.50 ea.**  
11 + **\$33.50 ea.**



Check your local branch for pricing

[www.dadant.com](http://www.dadant.com)



51 S. SECOND STREET, HAMILTON IL 62341 • PHONE (217) 847-3324 • FAX (217) 847-3660 • TOLL FREE 1-888-922-1293  
• CHICO, CA (877) 332-3268 • FRESNO, CA (877) 432-3268 • PARIS, TX (877) 632-3268 • SIOUX CITY, IA (877) 732-3268 •  
• WATERTOWN, WI (877) 232-3268 • ALBION, MI (877) 932-3268 • WAVERLY, NY (877) 532-3268 •  
• CHATHAM, VA (800) 220-8325 • FRANKFORT, KY (888) 932-3268 • HIGH SPRINGS, FL (877) 832-3268 •

# Killer Honey Bees In Arizona

Patrick Pynes

*Here in the arid American Southwest – specifically Arizona – honey bees and beekeeping are distinctly different from other parts of the United States, like Ohio, Indiana, Montana, or North Dakota. These differences come from the fact that many Arizona beekeepers are working mainly or exclusively with Africanized, “killer” honey bees. Our domesticated colonies are living in a desert “sea,” surrounded by healthy, thriving, feral colonies of Africanized honey bees.*

*It is rare, but sometimes people who are not beekeepers are attacked and even killed by Africanized honey bees – not by the “killer” bees in our hives – but by these wild and feral colonies. These deaths have happened in Arizona, New Mexico, Texas, California, and Utah.*

*The commentary below was written in response to a news story about one such death. This story was published in the Camp Verde Bugle on July 12, 2017: <http://cubugle.com/news/2017/jul/12/man-dies-after-bee-attack/>*

*The commentary was written mainly for an audience of non-beekeepers, but what it has to say about Africanized bees is relevant to beekeepers, too.*

*As a beekeeper yourself, what do you think about these issues? If the Africanized bees come to where you live, how will you respond? The extreme defensiveness (“aggression”) of some Africanized bees is their major “bad” characteristic, of course. But what are some of the good things (like resilience) that these bees have already brought to beekeeping and beekeepers in Arizona and the rest of the “Africanized zone,” north of the USA/Mexico border? Exploring and considering these kinds of questions is what this commentary is all about.*

**A**s an Arizona resident who is also a beekeeper, I was saddened to read of a man’s death by honey bees in a story that was published by the *Camp Verde*

*Bugle* on Wednesday, July 12, 2017. This man’s death is a tragedy, and I extend my condolences to his family and friends, on my behalf and on behalf of the Northern Arizona Organic Beekeepers Association (NAOBA).

As a beekeeper who loves the honey bees, I am always deeply saddened to learn about these rare incidents that result in the death of a fellow human being. It is unusual for honey bees to attack and kill members of our species; however, it does, of course, sometimes happen, and such deaths are not always entirely avoidable, although they are rare. As the saying goes, “nature bats last”: accidents will happen, and sometimes lightning or other forces of nature kill one of our own, seemingly “out of the blue.”

**H**ere in Arizona and the Desert Southwest we have been living with a different kind of honey bee since the early 1990s. This honey bee, of course, is the so-called “killer” bee, or “Africanized” honey bee. Although she is the same species (*Apis mellifera*) as the temperate honey bee that our Spanish-speaking and English-speaking ancestors brought to the Americas from Europe beginning in the 1500s, her origins are in southeast Africa.

Africanized honey bees are of (dry) tropical origin. Evolution and ecology have adapted these bees to a much drier and harsh environment than the wetter, more verdant environments of northern Spain, England, and Germany. The dry, thorn-scrub savannah that Africanized honey bees came from in South Africa and Tanzania are remarkably similar to the dry mesquite/acacia savannah of central Arizona and the Verde Valley. Here we also have the “prickly,” arid-adapted plants and dry/wet seasons of the Africanized bees’ former homelands.

After having been imported as a few dozen African queens from

South Africa/Tanzania to Brazil in 1956 – to help improve the struggling Brazilian honey industry – Africanized honey bees spread rapidly northward through South, Central, and North America. They have been in Arizona since the early 1990s.

**T**oday, the honey industry in Brazil is thriving, and all of that honey (much of it imported into the United States) is being produced by beekeepers who are working with productive and resilient Africanized honey bees. Meanwhile, the temperate/European honey bee that most industrial beekeepers in the U.S. rely upon is suffering from Colony Collapse Disorder (CCD) and other maladies. Over two-thirds of the honey consumed here in the U.S. is imported from other countries, like Brazil.

It was “killer bees,” of course, who killed the man who was driving a backhoe in the Wickenburg area on Tuesday, July 11, 2017. We mourn his death.

At the same time, we need to inform and educate ourselves about how and why this tragedy happened, in the hopes that perhaps another such death by honey bees can be prevented in the future, especially here in central and northern Arizona.

So-called “killer” bees are not really killers, except on these rare occasions. In fact, these “killers” are much more about life than death, because, like other pollinators, they pollinate (fertilize) so many of the fruits, vegetables, and nuts that we eat. To make their own living as “florivores,” gathering nectar and pollen from flowering plants, they do not kill any other species, period. Can the same be said about human beings, even those who choose to eat plants only?

Unlike a colony of temperate/European honey bees, a colony of tropical/South African honey bees does have the capacity to kill another species, whenever that colony (a

single organism) feels as if its own life is threatened. When temperate honey bees feel threatened, one or more guard bees will sting whatever is threatening them (a hungry black bear, for example), but only a handful of bees or a few dozen at most will do the stinging. Because of the fishhook-like barb on her stinger, each honey bee who stings also dies. She gives up her life in order that her colony may live.

Because they evolved in a dry tropical environment, and in a different relationship with human beings (until recently, the “killer” bees were not domesticated), some Africanized honey bee colonies respond much more defensively than temperate honey bees to a real or perceived threat to their life and well being. A disturbed tropical colony’s response to a threat is much more social than the typical European colony’s more individualized response.

Once the alarm pheromone (which smells a lot like a banana) is in the air, nearly an entire colony of many thousands of individual bees will together attack whatever seems to be threatening them within their close vicinity. In South Africa, that might be a honey badger or a human being who is a honey hunter. Here in Arizona, it might be a person who is operating a loud, vibrating machine, like a lawnmower, a weed eater, or a backhoe.

Honey bees don’t really hear, but they do have an acute sense of smell (better than a dog’s), and they are sensitive to nearby vibrations, especially from heavy machinery. If the vibrations are perceived to be a real threat, many thousands of bees can attack that threat by stinging and attempting to suffocate what they identify as a predator. Thousands of honey bees may die in defense of the hive, but that’s a worthwhile sacrifice for a species living in a dry, tropical environment. The rains may not come again for several months, but the colony that just sacrificed much of its population in defending itself will still be alive when the moisture and flowers finally return. Until that happens, the colony will still have the food and babies that it protected from its attacker.

In a much more lush, temperate environment, a European colony

will defend itself by delivering only a few dozen stings to a predator, who might be able to steal ALL of the colony’s food and brood (babies), if the attacker can get beyond this first line of defense. Losing much or most of a colony’s stores is a regrettable but tolerable loss, because, except in Winter, there will be plenty of moisture and flowers for the colony to rebuild itself, even from “scratch.” The rains and flowers are much more predictable in a temperate environment. For temperate honey bees, the dying of so many bees in defense of the colony would not be worth it.

For tropical honey bees, however, who evolved in a mainly dry, more unpredictable environment, losing so many bees to protect the whole colony IS worth the sacrifice. Therefore, when threatened, especially when food is scarce and the weather is hot and dry, a threatened honey bee colony attacks “enmasse.” This response might have been different in May or June, when the weather was slightly cooler and the mesquite trees were still covered in flowers. Even temperate honey bees are often “crankier” when it’s hot and dry and the colony is hungry for fresh nectar and pollen. It’s the same in the Fall, when the flowers are fading away. All Western honey bee colonies have moods, just like us.

All Western honey bees (*Apis mellifera*) have also evolved to protect their precious honey stores and wax combs by going for a mammal’s face, mouth, and eyes: where we are most vulnerable. That vulnerability is why we beekeepers wear a veil. Africanized bees often suffocate people or other animals by entering their nose and throat so that they can no longer breathe.

If the man who was driving the backhoe on a very hot July day had only been wearing a veil, it’s possible that he could have avoided death. Once the bees attacked because the backhoe hit their combs or the machine’s vibrations set off the alarm pheromone, he could have escaped with only a few dozen or even a few hundred stings. The veil would have protected him.

Most people, of course, don’t wear veils when working outdoors, except for beekeepers.

But there are other “pro-

active” things that we can do to prevent tragedies like this one from happening and that we can do if we find ourselves in a situation where we are under attack by a colony.

**First**, be very aware and careful if you are using loud, vibrating machinery outdoors, like mowing the lawn. Be very aware of your surroundings and look for hidden places where a colony of honeybees might be living. Look for holes or cracks in walls or eaves where forager bees may be coming in and out. Some Africanized colonies may even be living in completely exposed places, like underneath the eaves of a house. If you are unsure about the possible places where a feral colony may be living on your property, contact a local beekeeper to consult with you. After years of experience, we can often see where they are, when others cannot.

Beekeepers call these “feral” colonies: these are essentially wild colonies of bees that are not regularly interacting with human beings, like beekeepers. These feral colonies are the most potentially dangerous. If you encounter a feral colony on or near your property, call a beekeeper first and a pest control operator second. A beekeeper will usually remove a feral colony alive. It is skilled work that takes time and expertise, so a fee will usually be charged. Usually, that fee will be the same or less than what a pest control operator will charge for killing the bees.

**Second**, if you come across a colony of feral honey bees (99.9 percent of Arizona’s feral colonies are Africanized), don’t panic. Honey bees are incredibly hard workers. They may be working so hard that they won’t even notice you. Respect them and do not get too close to them or disturb them in any way.

Remember also that not all Africanized honey bees are highly defensive (“aggressive”). In my own experiences as an Arizona beekeeper, I (and many others) have discovered that some of the “killer” bees are highly defensive and even dangerous; others are only moderately defensive, depending on the season and other factors; and others are entirely or nearly docile, just like most of the temperate honey bees. The “killer” honey bee is a gross stereotype. We

# Mite Away<sup>®</sup> QuickStrips



## SAME QUALITY PRODUCT SINCE 2011

MAKE SURE BEES ARE WELL FED BEFORE TREATMENT. WE RECOMMEND TREATMENT OF A FULL DOSE BEFORE SPLITTING COLONIES. MONITOR YOUR MITE LEVELS PRE AND POST TREATMENT. TREAT WITHIN 50°- 85°F, FIRST 3 DAYS ARE MOST CRUCIAL.

## HEAR WHAT COMMERCIAL BEEKEEPERS HAVE TO SAY ABOUT TREATING WITH MITE AWAY QUICK STRIPS

Visit our YOUTUBE channel:  
PROPER APPLICATION



Scan Me!

### LIFE CYCLE OF THE VARROA MITE

### NABC CONFERENCE:

COMMERCIAL BEEKEEPER PANEL featuring Woodworth Honey Co., Pendell Apiaries and Swan's Honey. @NODAPIARY

READ ALL THE **FAQS** ON OUR WEBSITE!

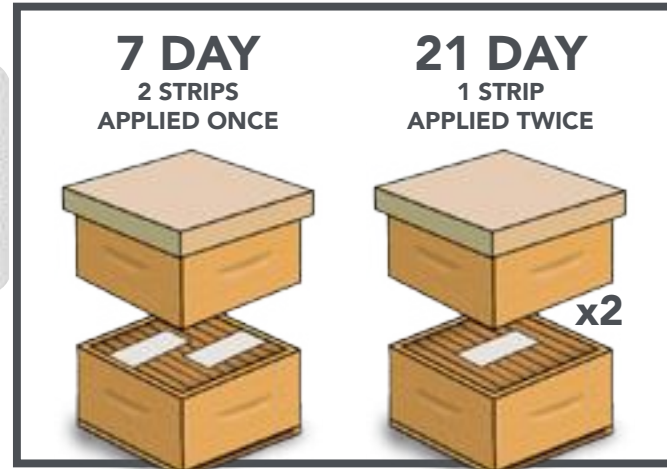

## TREATMENT OPTIONS



# Bee Cozy

WINTER HIVE WRAPS



**PROTECTIVE**  
Supports the bees through the cold winters & helps maintain ambient temperatures.



**EFFICIENT**  
Save valuable time with our slip on, slip off method!



**AFFORDABLE**  
With a long life expectancy, annual costs are minimal.



**SUSTAINABLE**  
Built from environmentally friendly materials.

PLEASE NOTE: THIS ADVERT IS NOT A SUBSTITUTE FOR FOLLOWING THE COMPLETE LABEL INSTRUCTIONS. ALWAYS READ AND FOLLOW THE LABEL.

*Healthy Bees. Healthy Planet.*

To learn more call 866-483-2929 or visit [www.NODGLOBAL.com](http://www.NODGLOBAL.com).



need to get beyond such distorted, one dimensional thinking.

**Third**, if you come into the presence of the dangerous and powerful force of nature that is an attacking colony of Africanized bees, cover your face (mouth, nose, and eyes) with your hands or with a shirt or hat and run as fast as you can to the closest indoor shelter, like a house or car. If no such place is available, keep running until the bees give up their pursuit. If you still have your wits about you, run through shrubs, trees, or bushes so that the pursuing bees will lose your trail. They are less likely to pursue through dense vegetation.

The chances of being attacked and killed by a colony of Africanized honey bees are about the same as your chances of being killed by lightning. Of course, here in Arizona, we have plenty of both, and especially of lightning during monsoon season. But there are ways to avoid being attacked or struck. Even so, sometimes it happens. Nature bats last.

We beekeepers are very concerned about public safety and about the public's understanding of honey bees and of beekeeping in general. Here

in Arizona, the reality is that many of us are working with Africanized honey bees. We have to, because the temperate honey bees do not thrive in the desert. By our carefully working with these bees, learning how to interact peacefully with them and by selecting the most gentle queens among the "killers," we are actually helping to "cool down" the most defensive Africanized honey bees that live among us, both in hives and in feral situations.

Today, in contemporary Brazil, the beekeeping industry is thriving, and far fewer people are being stung or killed by honey bee colonies than during the 1960s, following the initial "African" invasion. Over time, beekeepers and the public have adjusted to the new reality, just as the bees themselves have adjusted themselves to a new continent, and to new but familiar places like the Verde Valley, where they are thriving. If the Brazilians have done it, then we Arizonans can, too, and we can do it in our own unique and successful ways.

*By Patrick Pynes  
President, Northern Arizona Organic  
Beekeepers' Association, Flagstaff*



**AMERICAN BEE JOURNAL**

Free Sample Copy!

**SUBSCRIBE NOW**  
THE BEEKEEPER'S COMPANION  
SINCE 1861

Save \$ By Reading the  
*American Bee Journal*

Many subscribers say they easily save the cost of an entire year's subscription from a single informative article in the *American Bee Journal*. Free sample copy upon request.

1-888-922-1293  
[www.americanbeejournal.com](http://www.americanbeejournal.com)

### 2018 Bee Culture Calendar Contest

### BEEYARDS AT SUNSET!

Look for shadows, look at seasons, look at your hives from the other side, from your neighbor's place, from upstairs. See your 2017 Calendar for contact and instructions.



# Valley Bee Supply, Inc.

46 Tinkling Spring Rd, Fishersville, VA 22939

**Woodenware Manufacturer**  
**Tools & Smokers**  
**Protective Clothing**  
**Nutrition**  
**Medicines**  
**Extractors**  
**Extracting Equipment**  
**Containers**  
**Bottling Equipment**

**FREE SHIPPING**  
Orders over \$99

Phone: 540-941-8127 [www.ValleyBeeSupply.com](http://www.ValleyBeeSupply.com) Toll Free: 866-220-0198

Photo Credits: Jennifer Smith, Lexington, VA



# Betterbee®

## Proud Supplier of LYSON Candle Molds

**FS143 Weave Cylinder**  
Size: 2-5/8" tall  
Wax Used: 5.6 oz.  
\$23.95



**FS114 Old Skep**  
Size: 3-1/2" tall  
Wax Used: 2.9 oz.  
\$29.95



**F017 Small Honeycomb**  
Size: 2-7/8" tall  
Wax Used: 1.3 oz.  
\$19.95



**FS17 Tree Decorated**  
Size: 7-4/5" tall  
Wax Used: 9.9 oz.  
\$44.95



**FS47 Large Ball**  
Size: 3-1/2" tall  
Wax Used: 12.9 oz.  
\$39.95



**FS82 Little Flat Hen**  
Size: 1-1/3" tall  
Wax Used: .68 oz.  
\$18.45



**FS86 Rabbit**  
Size: 1-5/8" tall  
Wax Used: 1.5 oz.  
\$19.95



**FS111 Turtle**  
Size: 1-5/8" tall  
Wax Used: .93 oz.  
\$19.95



**FS91 Sparrow**  
Size: 2" tall  
Wax Used: 1.6 oz.  
\$28.95



**FS100 Hedgehog**  
Size: 1-1/2" tall  
Wax Used: 1.1 oz.  
\$18.45



**FS60 Cast Cylinder**  
Size: 3-3/4" tall  
Wax Used: 12.5 oz.  
\$33.95



**FS03 Cylinder Snowflake**  
Size: 4-1/2" tall  
Wax Used: 7.1 oz.  
\$29.95



**FS04 Ball Snowflake**  
Size: 2-5/8" tall  
Wax Used: 6.7 oz.  
\$29.95



**FS35 Fading Rose**  
Size: 4-1/2" tall  
Wax Used: 8.1 oz.  
\$39.95



**FS60 Cast Ball**  
Size: 3-1/2" tall  
Wax Used: 10.1 oz.  
\$39.95



**FS22 Fir Tree**  
Size: 5-1/2" tall  
Wax Used: 6.2 oz.  
\$40.95



**FS29 Cube with Cone**  
Size: 3" tall  
Wax Used: 10 oz.  
\$21.95



**FS02 Medium Cone**  
Size: 3" tall  
Wax Used: 2.9 oz.  
\$19.95



**F147 Tiny Frog**  
Size: 7/8" tall  
Wax Used: .34 oz.  
\$16.95



**FS38 Petite Rose**  
Size: 1-1/4" tall  
Wax Used: .32 oz.  
\$16.95



**Over 80 molds available, and more on the way!**

**ROOT**<sup>®</sup>  
CANDLES

Pure and natural beeswax  
blended with unexpected  
fragrances



[www.rootcandles.co.uk](http://www.rootcandles.co.uk)

[www.rootcandles.com](http://www.rootcandles.com)

**Root Candles America**

623 W. Liberty St.  
Medina, OH 44256

(800) 289-7668 - e: [westliberty@rootcandles.com](mailto:westliberty@rootcandles.com)

**Root Candles Europe**

Root House, Foundry Street, Brighouse, Huddersfield  
West Yorkshire, HD6 1LT

Tel: 01484 850059 - e: [info@rootcandles.co.uk](mailto:info@rootcandles.co.uk)

The development of a honey bee larva depends on a complex proteinaceous secretion of the cephalic (relating to the head) glandular system of nurse bees, the so-called larval jelly or bee milk. The quantity and composition of larval jelly which is provided to individual larvae by the nurse bees differs according to sex, caste and age of the larvae (Haydak 1970; Asencot and Lensky 1988; Brouwers et al. 1987). The larval jellies- royal (RJ), worker (WJ) and drone jellies (DJ) – differ in the ratio of fructose to glucose and in the content of the vitamins and proteins (Brouwers et al. 1987; Brouwers 1982, 1984; Thrasyvoulou 1983).

Royal jelly is a part of the diet of honey bee larvae and it plays a major role in caste differentiation. Royal jelly is derived from secretions of both the hypopharyngeal and mandibular glands of nurse bees (Knecht and Kaatz 1990; Lensky and Rakover 1983). Newly emerged bees have undeveloped hypopharyngeal and mandibular glands. Hypopharyngeal glands are paired glands inside worker's heads, consisting of a long central duct with many acini attached. The glands will only develop after consuming large quantities of pollen for the first seven to 10 days. The hypopharyngeal glands first secrete the protein rich component of royal jelly in young bees, but then secrete invertase, which is used to convert sucrose to simple sugars (fructose and glucose), in foragers. Mandibular glands are simple, sac-like structures attached to the base of each mandible. The glands secrete lipid-rich components of the royal jelly in young bees, but produce an alarm pheromone (2-heptanone) in foragers (Huang 2010).

The behavior of nurse bees provisioning brood cells was studied by using video equipment to make long-term recordings of individual queen and worker larvae from hatching until the brood cell was sealed. The contents of water, sugars, proteins, lipids and free amino acids were determined for larval food collected from brood cells containing drone, worker or queen larvae. The feeding pattern of queen larvae hardly altered during their development; most feedings occurred during relatively short (<50 seconds) visits of nurse bees and the composition of the royal jelly remained nearly constant. In worker larvae short feedings were regularly observed during the first 48 hours of development but in the subsequent period of 36 hours almost all feedings were of long (>50 seconds) duration. In this period a marked decline was observed in the glucose/fructose ratio for worker jelly. After 84 hours of larval age, feedings of long duration were interspersed with feedings of short

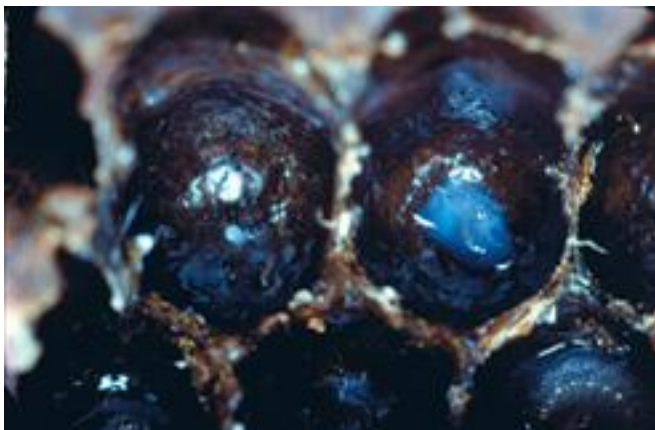

*First instar worker with royal jelly. Note egg on left.*



# A Closer LOOK

## PROTEINACEOUS LARVAL JELLY

Clarence Collison

*Royal jelly is a part of the diet of honey bee larvae and it plays a major role in caste differentiation.*

duration. At this stage the total sugar content of worker jelly increased and the contents of proteins and lipids decreased simultaneously (Brouwers et al. 1987).

Hypopharyngeal glands isolated from bees feeding younger worker larvae (making long visits) displayed high rates of in vitro protein synthesis. Most glands from bees feeding queen larvae (brief visits) demonstrated reduced synthetic activity. It was suggested that the duration of the larval feedings is related to the origin and consequently to the composition of the food secreted by the nurse bees (Brouwers et al. 1987).

The contents of glucose, fructose and sucrose were determined in the natural diets of male and female honey

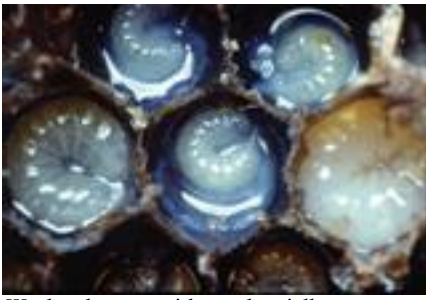

Worker larvae with worker jelly.



Nurse bees feeding larvae.



Drone brood have a different diet.

bee larvae reared under various conditions (Brouwers 1984). Glucose was predominant during the early larval stages of workers and drones, but fructose became the main sugar component in the food of older larvae. In the diet of queen larvae, glucose remained the main sugar component throughout the larval period. The abundance of food supplied to worker larvae after a broodless period was characterized by extremely low glucose content.

Newly emerged larvae were reared in the laboratory on <sup>32</sup>P-labeled royal jelly. The resulting adults were classified as workers, intermediates, or queens, depending on their morphological caste characters. Larvae destined to become queens ate 13% more food than worker larvae during the first three days of larval life. This difference increased to about 40% after six days of larval life. The mean rate of ingestion was 8% less in intermediates as compared to queen larvae during the first three days after hatching, and 16% less after six days of larval life. Queen larvae consumed an average of 5% more royal jelly than intermediates, and 19% more than workers (Dietz and Lambremont 1970).

Thrasylvoulou (1983) studied the changing patterns of honey bee larval food proteins during larval life with polyacrylamide disc electrophoresis. When sodium dodecyl sulfate detergent was used the number of protein bands increased from 10 to 15 in worker jelly, from eight to 10 in royal jelly and from 11 to 13 in drone jelly. Patterns of older worker and drone larval diet were more complex than those of queen larval diet. Comparing the results with a previous analysis, slight differences in protein patterns between two races of bees (*Apis mellifera cercropia* and *Apis mellifera liquistica*) were found.

Measurements were made of oxygen uptake and carbon dioxide evolution, during the first 24 hours of life, by larvae on substrates of different age and type. These substrates included royal jelly, the hypopharyngeal secretion fed to larvae destined to become queens, which varied in age from 0 to 96 hours; the hypopharyngeal secretion fed to young larvae destined to be workers, which varied in age from 0 to 60 hours and which was termed "worker jelly"; and the food supplied to older worker larvae, composed of a hypopharyngeal secretion modified by an admixture of honey and pollen, termed "modified jelly". The pattern and magnitude of oxygen uptake was similar on all substrates. Net carbon dioxide evolution by larvae on royal jelly or modified jelly was highly positive; net carbon dioxide evolution by larvae on worker jelly was slightly negative. Microchemical analyses showed that royal jelly differed in composition from worker jelly and modified jelly. The composition of royal jelly remained relatively constant with age. The addition of sugars to worker jelly produced an increase in carbon

dioxide output which was nullified by the further addition of an extract of the water-soluble acids of royal jelly. The differences observed in carbon dioxide evolution by young larvae on worker jelly and royal jelly were considered to be an expression of the initiation of female dimorphism (Shuel and Dixon 1959).

Norms were established for respiration, growth, and tissue composition of 0- to 72-hour-old female honey bee larvae reared in the laboratory on natural royal jelly and worker jelly diets. The worker jelly diet was then altered experimentally in the direction of royal jelly through additions of sugar and certain water-soluble acids of unknown structure extracted from royal jelly, but present in the natural diets of larvae of both female castes. In general, developmental norms were shifted in the direction of the norms of larvae fed royal jelly, but the changes were not fully coordinated. The added acids were strongly growth inhibitory. A high inverse association between the total water-soluble acid content of the diet and larval weight suggested that the acids may represent a nutritional growth-regulating mechanism. The evidence indicates that nutrient balance is significant in the early development of the dichotomy between female castes, and that no single constituent determines the ultimate development of either caste (Dixon and Shuel 1963).

As larvae, drones have different protein and sugar requirements than workers, and in each life stage drones and workers differ in body composition (percentages of glycogen, lipids and proteins (Hrassnigg and Crailsheim 2005). The investment of nurses to raise an individual drone larva far exceeds that for a worker larva (Haydak 1970). This is reflected in the increased tending of drone larvae (Calderone and Kuenen 2003), and it obviously can be deduced from the weight gain of larvae during the larval period. Worker larvae reach a maximum fresh weight, measured at the time of cell sealing, of 144-162 mg, and drone larvae reach 262-419 mg. Thus, drone larvae attain 1.8-2.6 times the weight of worker larvae (Hrassnigg and Crailsheim 2005).

The composition of royal jelly varies with seasonal and regional conditions. Variations in royal jelly composition can result from: the nutritional condition and age of the contributing nurse bees; the age of the queen larvae which influences the amount of sugar; and trace minerals resulting from the distinct compositions of pollens among plant species (McNeil and Schmidt 2015).

The average moisture content of royal jelly is 60-70%, crude protein 12-15%, total sugar 10-16%, lipids 3-6%, vitamins, salts and free amino acids. The crude protein of royal jelly consists of water-soluble and water-insoluble proteins. The water-soluble proteins make up 46-89% of the total proteins (Smitzová et al. 1998). Major proteins



**YOUR FIRST CHOICE FOR HEALTHY BEES**  
 Proudly serving the beekeeping industry  
 for over 30 years

Available  
 from your beekeeping  
 supplies dealer



**Medivet Pharmaceuticals Ltd.**

#4, 55 - 9 Avenue SE, High River, Alberta, T1V 1E6, Canada  
 Tel 403 652 4441 Fax 403 652 3692 [info@medivet.ca](mailto:info@medivet.ca) [www.medivet.ca](http://www.medivet.ca)

# OXALIC ACID

**MOST COST EFFECTIVE  
 VARROA TREATMENT  
 ON THE MARKET**

## Start Treating your New Package of Bees Early

In a package, 100% off the mites will be exposed. Just one treatment of Oxalic Acid will have a 95% + efficacy on broodless colonies and give your bees the head start they will need to stay strong this year! It is also just as effective on broodless colonies in Early Spring/Late Fall.

**PERFECT FOR**

**Swarms • Packages • Clean Splits**



[www.BrushyMountainBeeFarm.com](http://www.BrushyMountainBeeFarm.com) | 1-800-233-7929



# Brushy Mountain Bee Farm

*Serving Beekeepers with the Best for 40 YEARS*

**BEST QUALITY | BEST SERVICE | BEST SUPPORT**



Queen larvae have more than enough food all of the time.

of royal jelly are members of the (MRJP=major royal jelly protein) family. Total protein is comprised of 52 different proteins. The majority of the identified proteins (47 out of 52) are members of the major royal jelly protein family (MRJPs), named as MRJP1 through 6, each of which has many variations (Huang 2010). Proteins MRJP3 and MRJP5 are polymorphic (Albert et al. 1999; Huang 2010). MRJPs account for 82 to 90% of total larval jelly protein and they contain a relatively high amount of essential amino acids. Schmitzová et al. (1998) found that royal jelly and worker jelly contain identical major proteins.

The consumption of royal jelly determines the differences between castes and behavioral development in the honey bee due to several epigenetic RNA occurrences on future queen larvae. However, it is not known whether the proteins of royal jelly are related to these differences, or which proteins are responsible for the changes. To understand the functions of royal jelly proteins that are present in other tissues of the bee, in addition to the hypopharyngeal gland, Peixoto et al. (2009), used a polyclonal antibody anti-MRJP1 to investigate the presence of this protein in the honey bee nervous system. This study showed the presence of three polypeptides (p57, p70 and p128) in specific tissues of the bee brain. Mushroom body, optic lobe and antennal lobe neuropils all contained proteins recognized by anti-MRJP1. Proteomic analysis showed that the three polypeptides are correlated with proteins of the MRJP family. P57 is correlated with MRJP1, p70 with MRJP3, while p128 may be an oligomeric form or a new polypeptide. Immunostaining of the brain and hypopharyngeal gland revealed differential expression of MRJPs in various brain regions and in different honey bee castes and subcastes. The identification and localization of these MRJPs contribute to the elucidation of the biological roles of this protein family.

In addition to protein, royal jelly also contains many trace minerals, some enzymes, antibacterial and antibiotic components, and trace amounts of vitamin C. The fat-soluble vitamins, A, D, E, and K are absent from royal jelly. Three enzymes were also detected in the royal jelly: glucose oxidase, peroxiredoxin and glutathione s-transferase (Huang 2010). **BC**

## References

- Albert, Š., J. Kludiny and J. Šimůth 1999. *Molecular characterization of MRJP3, highly polymorphic protein of honeybee (Apis mellifera) royal jelly*. Insect Biochem. Mol. Biol. 29: 427-434.
- Asencot, M. and Y. Lensky 1988. *The effect of soluble sugars in stored royal jelly on the differentiation of female honey bee (Apis mellifera L.) larvae to queens*. Insect Biochem. 18: 127-133.
- Brouwers, E.V.M. 1982. *Measurement of hypopharyngeal gland activity in the honeybee*. J. Apic. Res. 21: 193-198.
- Brouwers, E.V.M. 1984. *Glucose:fructose ratio in the food of honey bee larvae during caste differentiation*. J. Apic. Res. 23: 94-101.
- Brouwers, E.V.M., R. Ebert and J. Beetsma 1987. *Behavioural and physiological aspects of nurse bees in relation to the composition of larval food during caste differentiation in the honeybee*. J. Apic. Res. 26: 11-23.
- Calderone, N.W. and L.P.S. Kuenen 2003. *Differential tending of worker and drone larvae of the honey bee, Apis mellifera, during the 60 hours prior to cell capping*. Apidologie 34: 543-552.
- Dietz, A. and E.N. Lambremont 1970. *Caste determination in honey bees. II. Food consumption of individual honey bee larvae, determined with 32P-labeled royal jelly*. Ann. Entomol. Soc. Am. 63: 1342-1345.
- Dixon, S.E. and R.W. Shuel 1963. *Studies in the mode of action of royal jelly in honeybee development: III. The effect of experimental variation in diet on growth and metabolism of honeybee larvae*. Can. J. Zool. 41: 733-739.
- Haydak, M.H. 1970. *Honey bee nutrition*. Annu. Rev. Entomol. 15: 143-156.
- Grassnigg, N. and K. Crailsheim 2005. *Differences in drone and worker physiology in honeybees (Apis mellifera)*. Apidologie 36: 255-277.
- Huang, Z. 2010. *Honey bee nutrition*. Am. Bee J. 150: 773-776.
- Knecht, D. and H.H. Kaatz 1990. *Patterns of larval food production by hypopharyngeal glands in adult worker honey bees*. Apidologie 21: 457-468.
- Lensky, Y. and Y. Rakover 1983. *Separate protein body compartments of the worker honeybee (Apis mellifera L.)*. Comp. Biochem. Physiol. 75: 607-615.
- McNeil, M.E.A. and J.O. Schmidt 2015. *Other products of the hive*. In: *The Hive And The Honey Bee*, (Ed. J.M. Graham), Dadant & Sons, Hamilton, IL., pp. 705-775.
- Peixoto, L.G., L.K. Calábria, L. Garcia, F.E. Capparelli, L.R. Goulart, M.V. de Sousa and F.S. Espindola 2009. *Identification of major royal jelly proteins in the brain of the honeybee Apis mellifera*. J. Insect Physiol. 55: 671-677.
- Schmitzová, J., J. Kludiny, Š. Albert, W. Schröder, W. Schreckengost, J. Hanes, J. Jůdová, and J. Šimůth 1998. *A family of major royal jelly proteins of the honeybee Apis mellifera L.* Cell. Mol. Life Sci. 54: 1020-1030.
- Shuel, R.W. and S.E. Dixon 1959. *Studies in the mode of action of royal jelly in honeybee development*. Can. J. Zool. 37: 803-813.
- Thrasyloulou, A.T. 1983. *Native and dissociated protein patterns of larval food of honey bees (Apis mellifera cecropia L.)*. Apidologie 14: 225-232.

Clarence Collison is an Emeritus Professor of Entomology and Department Head Emeritus of Entomology and Plant Pathology at Mississippi State University, Mississippi State, MS.

The bee is the wisest and  
cleverest of all animals  
and the closest to man in  
intelligence.

# Instinct vs. Intelligence

David Donnelly

These words were written 11 centuries ago, after Byzantine emperor Constantine VII ordered scholars to compile centuries of information on farming, going back to the Greeks and Romans. The resulting work, *Geoponika: Farm Work*, has recently been translated for the modern reader.

Modern day researchers also recognize the European honey bee is one of the world's most sophisticated and interesting creatures. Through a combination of individual and colony behavior, it can learn, adapt, communicate, divide up its labor, utilize senses of direction, sight, and smell, help propagate its colony, and engage in skills far in excess of its relative brain capacity. A bee has one million neurons, compared to a human's 100 billion neurons. Research has shown that they have the ability to learn from their experiences in spite of their brain size. Inquiring minds want to know, "Are their skills hard-wired, i.e. instinctual, or are they capable of learning and abstract thought that borders on intelligence?" If we interpret their actions correctly, we may see a level of intelligence and creativity far in excess of their brain size and their place on our planet as a lowly insect.

## Primitive Consciousness

Andrew Barron and Colin Klein from Macquarie University in Sydney, Australia, propose that insects have the capacity for consciousness, or awareness, due to the "intricate circuitry" of their brains. It's doubtful that they fly around contemplating the meaning of life, but they do have the capacity to feel something, even on a primitive level.

*Instinct vs. Intelligence* is a dichotomy that we simple bee fans will continue to disagree on till the cows come home. The experts don't agree which is the dominant force, so don't expect to find a conclusive verdict here. You will have to decide

for yourself, or like most of us, just embrace the mystery of it.

We can enjoy tending to our bees on a regular basis, even though we do not live in a research lab or even give a hoot about the scientific method. We see the consistent patterns of brood, the way they tend for their young, guard their home against predators, bring home the bacon as hard as it may be to find sometimes, build comb, clean their hives, turn nectar into liquid gold through cooperation with other bees, prepare for Winter even though they have not lived long enough to know what Winter is, and honor her royal highness. How could they be anything but smart? At this point, some of you may wish to shout, "On the contrary, you've just described the definition of honey bee instinct!"

So let's look more at the issue of instinct to understand honey bee behavior. In other words, what are they pre-programmed to do? The female workers' tasks change throughout their short life, as nurse bees, house bees, scout bees, guard bees, and foragers. We know that the queen's pheromones have a great influence on their behavior, but where do we draw the line between instinct, queen influence, and learned intelligence? Research is

conducted along very specific, narrow lines, to weed out variables that could skew results. The cold eye of science can be very accurate and insightful, but can also ignore the wonderment of nature. To me, this is what makes beekeeping so fascinating. I don't view my bees with the detachment of a scientist, but with the awe of a fan. I view their abilities, whether intelligence or instinct, with curiosity, appreciative that they share their existence, and gifts of honey and wax with us.

## The argument for instinct

Wikipedia describes instinct as "the inherent inclination of a living organism towards a particular complex behavior." They cite nineteenth century French entomologist Jean-Henri Fabre, who described instinct as behavior that does not require cognition or consciousness.

Does that describe honey bee behavior, or is there more to it? In *The Hive and the Honey Bee*, (1992 edition), Norman Gary wrote the chapter titled, "Activity and Behavior of Honey Bees." He makes a strong argument that the behavior of honey bees is hard-wired, or instinctual. The bees unconsciously see a need within the hive and respond to it.

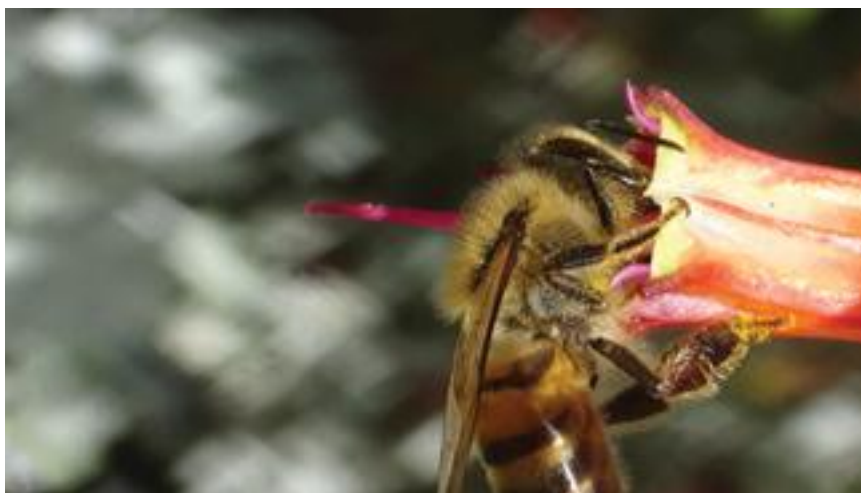



He cautions us against the tendency to “anthropomorphize” our understanding of bees, meaning to attribute human feelings, activities, and characteristics to non-human beings. Anthropomorphizing is a game we often engage in, for example when we think of a certain mouse who wears clothes, sings, walks on two legs, has a girlfriend named Daisy, and a dog named Pluto. However, there is a difference between anthropomorphizing for fun and trying to understand true honey bee behavior.

As an example, Gary says we typically think from a human standpoint that bees forage intensively to build up their honey reserves for the long, cold Winter that lies ahead. But with a life span of six weeks, a foraging bee wouldn’t know anything about the upcoming Winter. And most of them wouldn’t have to worry about it anyway because they’d be dead before then.

There are many words that we ascribe to bees, in an attempt to make sense of their behavior from a human point of view. They have “duties,” “responsibilities,” and “division of labor.” We say they are “angry” when they sting, “clever” when they build comb, and “ambitious” when they work overtime.

Gary says their activities are not nearly as brilliant as they seem to be. Nor do they involve a master plan for the betterment of themselves or

their colony. Each bee responds to a stimulus nearby, without awareness of the big picture.

Their age, genetic composition, internal and external factors, sensitivity to stimulus around them, and chemical and physiological changes that develop with age, are key factors that influence their activities.

Virtually all insect behavior is genetically programmed from the moment an egg is fertilized. They are basically biological robots, performing activities that favor the survival of the colony. Each bee’s response at any given moment is dependent on its condition. A bee near a cell containing larva responds differently than a bee near a queen. She might sense the stimulus of a hungry larva, and reflexively feed it. A bee carrying a particle of wax would be stimulated by a cell that needs to be capped. The more it responds to a particular stimulus, the more it learns and duplicates that behavior next time.

Do they know what they are doing? In all probability no, says Gary, even though their activity appears highly organized. All of their activities can be accounted for by reflexive or mechanistic responses. Thus, another anthropomorphic term such as “division of labor,” is not applicable, because it’s not done on purpose. As they age, their activities become more varied because of

physical ability and learning. He summarizes his thoughts on the subject with, “We must conclude that intuitive thinking or cognition, akin to that of humans, is probably non-existent in bees, or at least inconsequential.”

### The Argument for Intelligence

The Byzantine *Geoponika* goes on to explain why scholars from the Middle Ages feel bees are intelligent:

*“... its works is truly divine and of the greatest use to mankind. Its social life resembles that of the best regulated cities. In their excursions, bees follow a leader and obey instructions ...”*

Their appreciation of bees is impressive, and it is enlightening to know this knowledge existed in ancient times. But is advanced evolutionary behavior by insects proof of consciousness?

Jumping ahead several centuries again, researchers at Australian National University stated their research shows that “honey bees have a remarkably robust and flexible working memory, in spite of having a very small brain, and much fewer neural connections than the average vertebrate. ... It even hints at the emergence of a primitive intelligence from a small brain.”

We know that honey bee skills include color recognition, including ultraviolet light, and a strong sense of smell. They utilize these physiological traits to learn which colors, and which odors, are most rewarding for finding nectar. Among their other cognitive skills are the use of abstract thought and symbolic language, to distinguish landscape and the way home after foraging for distances of perhaps several miles. Learning through experience is a form of intelligence.

One of the greatest discoveries of abstract thinking among honey bees goes to Karl von Frisch, an Austrian who won the Nobel Prize in physiology and medicine in 1973. He and his team unlocked the key to the Waggle Dance, the elaborate pattern of movements in which bees communicate to others in their hive the location of such things as a good source of nectar, or a place to build a new hive after a swarm. He discovered that the “dance” (another anthropomorphic term), includes time and distance to a source, relative to the position of the sun, including

**“Instinct vs. Intelligence is a dichotomy that we simple bee fans will continue to disagree on till the cows come home.”**

## “Among their other cognitive skills are the use of abstract thought and symbolic language, to distinguish landscape and the way home after foraging for distances of perhaps several miles.”

any obstacles that may be in the way of their travel. And all this is communicated in the dark!

Other researchers have argued that visual dance isn't significant because of the dark. It may be the odor of the plants that lingers on the foraging bee after returning from the field that contributes to finding the source of the nectar. And still other researchers claim that sounds from the dancing bees are the key. In any event, the mystery and magic of the waggle dance are an ingenious form of communication.

Another school of thought has become popular lately that says consciousness lies not with the individual bees, but with the colony as a whole. Proponents use the term “superorganism.” The Merriam Webster Dictionary defines superorganism as, “A complex structure of interdependent and subordinate elements whose relations and properties are largely determined by their function of the whole.” Using this definition, the behavior of the colony dictates the behavior of the individual bees. Colonies are a complex structure of interdependent and subordinate elements--the bees. Social animals like bees cannot live alone, and their behavior only makes sense when viewed as colony consciousness. Through their collective behavior and short life span, they keep the colony alive and it is the colony which determines behavior. Jamie Ellis from the University of Florida writes, “Put a group of honey bees together and you get behaviors, attributes, characteristics, etc. that are otherwise absent in individual honey bees.” A colony is more than the sum of its parts.

Another study was conducted with bumble bees (alas not honey bees), led by Lars Chittka from London's Queen Mary University. They showed that bees could learn

to pull on a piece of string to release nectar. When new bees watched experienced bees pull the string, the new bees learned at a more rapid rate, successfully pulling the string 60 percent of the time.

In a recent issue of Science Magazine, some of the same researchers described how they trained bumble bees to move a ball to a target location to receive a treat. Chittka summarized, “... there is more and more evidence, both from experiments on small-brained insects and computational neuroscience, that small circuits can deal with exceptionally complex challenges.” This creative problem solving shows how new behaviors can develop as the need arises.

### **New Technology Unlocks Clues**

So we started out with a strictly instinctual, pre-programmed, robotic explanation of bee behavior. Then we mixed in learning from experience, communication through the waggle dance, and expanded it through superorganism behavior. Do these factors themselves conclude honey bee intelligence?

Newer technologies have enabled a level of research that was never available in the days of von Frisch. For example, today micro-electronic devices can be placed on bees to track their movement, and miniature video cameras can see inside dark hives.

In 2010, Thomas Seeley of Cornell University published his book *Honeybee Democracy*, which follows his adventures tackling honey bee communication and intelligence. In one experiment that he conducted on an isolated island, several swarms of bees had to choose their new home site from among several empty hives that he set up in different areas. Every box except one had problems as a home site, whether it was capacity, location, size of opening, etc. Each swarm had approximately

70 scout bees searching for their new home. The scouts advocated for different new homes based on their waggle dance. Through a process of elimination, persuasion, and promoting the advantages of their preferred choice, the swarms ultimately selected their new homes. They made the correct decision nine times out of 10 trials. With electronic trackers, Seeley was able to display graphically how the scouts walked through the interior of each hive they visited, checking out its suitability. He proved through group decision-making and brain power how the swarm scouts ultimately reached their final decisions. Quite a remarkable feat on the part of the bees.

### **The Debate Continues**

The arguments (and emotions) for instinct vs. intelligence are strong on both sides. Like so many factors in life, it is not a black or white issue. Do honey bees in fact perform their acts of brilliance, such as the waggle dance or selecting the best home site, without thought? If so, then perhaps the definition of intelligence, including consciousness and creativity, needs to be re-evaluated.

Anthropologic descriptions of honey bees allow us to romanticize them perhaps more than they deserve, but is that so bad? We cannot help but smile at the ancients (in *Geoponika*) who wrote that bees are “pleased by a good tune,” “hate laziness,” demonstrate “mechanical skill and near-logical understanding,” and “honor their king.”

Honey bees' placement on the consciousness scale of 1-100 will probably continue to move back and forth as new information comes to light. When and if we ever reach an ultimate conclusion regarding their range of instinct vs. intelligence, it will probably not change how we manage our six-legged “livestock,” or how much honey we manage to harvest. If anything, the ongoing mystery just adds to the fascination of these complicated, sometimes ornery, creatures of nature. **BC**

---

*David Donnelly holds a Doctor of Education (Ed.D.) degree, and is a backyard beekeeper.*



Manufacturer Of Quality  
Beekeeping Supplies Since 1976

Woodenware & Components  
Tools & Smokers  
Nutrition & Treatments  
Bottling & Extracting Equipment  
Protective Clothing



www.MillerBeeSupply.com | 496 Yellow Banks Road North Wilkesboro, NC 28659 | 1-888-848-5184

## Harvest The Best...

with SUNDANCE™ POLLEN TRAPS and COMPLETE ROSS ROUND SUPERS.



### SUNDANCE POLLEN TRAPS

Imagine the cleanest pollen available with no heavy lifting, chalkbrood mummies or risk of foulbrood scales. There is no substitute for the **Sundance Trap** quality and cleanliness. Leading experts from the USDA and universities as well as commercial beekeepers and hobbyists agree that **Sundance Traps** are the best pollen traps available.

### COMPLETE ROSS ROUND SUPER

Produce comb honey with no dripping from cut edges and no liquid honey in the consumer package with **Ross Rounds** equipment. Easily shipped or delivered, stocked on shelves, purchased and taken home without danger of leaking. Enjoy providing locally grown, unprocessed, all-natural honey with a complete **Ross Rounds Super**.

*For more information visit [www.RossRounds.com](http://www.RossRounds.com).*

*For dealers near you please email [sales@rossrounds.com](mailto:sales@rossrounds.com).*



# Beekeeping In Central South Carolina



## Mild Winters, Mites, Cotton and Soybeans

David MacFawn

---

I had a chance to discuss beekeeping in central South Carolina with Danny Cannon, who runs about 400 colonies and is in the Lexington (Columbia - Midlands) area of South Carolina ([beetrailfarm@gmail.com](mailto:beetrailfarm@gmail.com)).

Our Winters are mild and short in central South Carolina. Colonies typically raise brood year around, even in November and the first part of December. Last Winter (2016-2017) we really did not have any winter, except a cold spell in March. Drones typically start flying end of February to the first of March. It is the middle of August, as I am writing this article for the October magazine, cotton is toward the end of its bloom and has done well so far this year. We are monitoring the colonies for mites in August through the December time frame. If necessary, we will treat for mites as soon as the cotton honey supers are pulled in September. We have had well-spaced rain throughout the Summer. October is the month that we start our bee's Autumn (first frost).

Winter stores (pollen mainly) need to take us through to the first of February when red maple blooms. We also typically have a pollen dearth and the resulting "dry" brood in the later part of August through the first part of September. This dearth impacts Winter brood production. The honey stores need to take us from the September/October time frame through about the first of April when the nectar flow starts. We need to watch our honey supply very closely in March (the month prior to the nectar flow) to ensure the colonies do not starve when building up for the April through June Spring nectar flow.

Since we have brood year around, the mite levels remain elevated in Autumn, through November and December. South Carolina is unique from the Northeast in that the *Varroa* mite levels remain elevated and even may keep growing in the Autumn. There is a Summer dearth if the colonies are not located near planted crops like cotton. In September through November, we feed the colonies 2:1 syrup if necessary. Feeding begins in earnest



*Cotton in August.*



*Peanuts.*



*Danny's screen pallets.*

middle of September with the colonies finishing storing the syrup strategically until mid-November. This allows the brood chamber to be full without any gaps in the "honey." A medium super full of "honey" is desired. Our typical Fall flow from plants like asters and goldenrod is weak, with the colonies typically not being able to build up on asters and goldenrod. Danny is thinking about trapping pollen in January and February in coming years for a revenue source and feed for his bees.

The later part of November through the first part of December, treating with Oxalic Acid is recommended depending on the mite counts. Most beekeepers are now monitoring their mite levels every month, especially in the Autumn, September through December. Danny is planning on treating with Mite Away Quick Strips (MAQS) or Oxalic Acid. All extra supers are removed after the cotton flow is over around the first half of September, especially prior to treating for *Varroa* mites. Danny

samples his 400 colonies for mites but does not monitor each colony.

Splits, a minimum of three frames, but typically five-frames, can be made in August and September. A five-frame split is preferred since it provides a "buffer" on the time when it needs to be looked at. The split queen still has enough time to build up a reasonable number of bees prior to the January cold. Danny has found splitting in a five frame NUC works best with moving to larger equipment later. After splitting, Danny will typically be up to around 500 colonies. Hive wrapping is not necessary in the Winter. If the colony has sufficient number of bees, the colony is fine.

In January, the nighttime temperatures dip into the lower 30°F to upper 20°F, with it rarely getting into the upper teens. It is in the 40°F to 50°F during the day. In January, we typically have some days in the 60°F range. Often, we go into the colonies and check for a laying queen, food stores, and diseases making sure we reassemble the equipment in the same order. If we want to split our colonies around the first of March, we will start feeding 1:1 sugar syrup mid-January. Splitting around the first of March means our first workers hatch around mid-April.

Danny typically moves 48 hives plus supers on his flat-bed truck. His typical beeyard in the cotton fields are 36 to 48 colonies since the fields are large (2-500 acres). He uses four-way pallets and moves the colonies with a fork lift. Using a fork lift is a huge labor savings. Good dependable labor is difficult to find and keep.

Danny moves his colonies every year. The farmers rotate their crops with the main crops being corn, cotton, soybeans, and peanuts. There is some sunflower. Cotton provides the main Summer nectar flow with soybeans being second. Often, the farmers are planting their crops up to the field boundaries, leaving little space to place beehives. In this case, hives are typically placed on adjacent fields. Google maps is used to locate beeyards and provide driving directions. This allows Danny's wife to know where Danny is.

We have problems with Black Widow spiders around



*Simple cover with jars.*



*Reasonable frame of brood.*



Soybeans.

the hives. Hence, gloves are recommended when working the colonies. Especially, when moving the colonies by hand.

Danny does not go down into the hive each time when inspecting, unless when lifting the top, it is warranted. Wax moths are typically a good sign of a weak colony and the need for further inspection. He typically moves small splits and other “nurse” requiring colonies back to his home yard and leaves stronger colonies in the outyards year around. Splits/NUCs are as much a part

of his revenue as honey is. Danny also sells a few queens.

Mistakes made in the current year often do not show up until the following year. This may be things like – *Varroa* mite monitoring and treating, and determining good bee yards. Locating good beeyards is critical for honey production and hive health. Danny has “eased” into beekeeping growth to sync sales with supply. He sells honey throughout the Columbia metropolitan area. He is continually working to reduce his colony mortality rate. Survivor stock is an important component of his colony improvement operating strategy.

Danny uses screened pallets to move his bees. Two hives face in each direction on the pallet. The screening on the bottom ensures a steady airflow during the hot summers, also when moving the colonies. We need to be very careful about overheating when moving colonies.

Danny uses 23/32” covers with holes to insert feeder jars. These covers are cheap to make and last well. Since the weather is mild, we typically do not place extra brood chambers/deeps around the feeders. Unused syrup should be changed every week or so, especially in the Summer since it will ferment.

Danny uses mostly five frame NUCs to establish new colonies. He often inserts a queen cell that he raises to start the NUCs. Five frame NUCs allow more variability in time to inspect the NUC than smaller equipment.

Special thanks to the following for input into the article – Danny Cannon, Steve Genta, Staci Siler. **BC**

*David MacFawn has been keeping bees more than 50 years in the SE U.S. He’s a North Carolina Master Craftsman and South Carolina Master Beekeeper, and author of Beekeeping Tips and Techniques for the SE U.S. He lives in Lexington, South Carolina.*

We accept all major credit cards

PREMIUM QUALITY

QUEENS

AVAILABLE YEAR ROUND

HEALTHY QUEENS = HEALTHY HIVES

CONNECT WITH US!

OLIVAREZ HONEY BEES

OHB has been raising queens for more than 50 years. We raise Italian, Carniolan and Saskatraz queens and bees in the heart of Northern California and on Hawaii’s Big Island. These carefully chosen locations allow us to provide our bees with the purest environments and the best food sources, and to offer our customers premium quality queens and bees year round.

BIG ISLAND QUEENS

A division of Olivarez Honey Bees, Inc.

CALIFORNIA (530) 865-0298   HAWAII (808) 328-9249   TOLL FREE (877) 865-0298   OHBEES.COM

# STILL LEARNING

Claire Kimmel

We are still learning. It is a long desired hobby for my husband, but I have had much opportunity to be involved. After an unusually warm Winter, we had an unusually erratic Spring. Swarms were plentiful; we ended up catching seven and a half from our six hives. It is the half a swarm that became interesting.

On May 1<sup>st</sup> we noticed the little cast swarm huddled under the electric meter reader. It was about a third the size of a normal swarm. Then on the 2<sup>nd</sup> we heard weather predictions that the night time temperatures would be around 35 degrees by the 5<sup>th</sup>. Even if we put the cast swarm into a hive box, they would not make it through that kind of cold. We feel a special bond to our bees, and it grieved us to think of this little family freezing to death. But we are not skilled enough to do what experienced beeks would do, even if we knew what that was.

My husband says I am crazy, and I suppose he is right – what I did on May 3<sup>rd</sup> will prove it!

Like most beekeepers we have wanted to have an observation hive, traveling down many youtube and google rabbit holes about how to make one. Because we are radical re-cyclers (some might say borderline hoarders?) our basement is full of “Useful Things.”

I started with 2 windows. They are double paned, 22½” x 31”, wooden inside and aluminum outside. Placed together they would not have had enough space for bees. So I made some wood strips almost an inch thick and an inch wide and screwed these to the two sides and the top of one of the windows. When I laid the second window on top of this, it seemed like a good space for bees, but how to connect them? The aluminum cladding was on the outside of my new box, and I did not feel confident trying to drill through aluminum. So I made two wooden feet of the same inch thick wood, and used them to connect

the windows on the bottom and also extend out a few inches. They thus served to create the space needed for an outside entrance to the hive. I cut two short blocks of wood to connect the top side of the windows together. I had to close the back opening on the bottom to keep bees out of our bedroom, so I screwed in an inch square strip along the bottom of the back window. Now for a floor/landing board. We had a two inch thick board that was 7” wide. Here’s is where I just got lucky, because instead of cutting it the size of my new hive, I decided to cut it the length of the window opening. I cut out a groove on the underside for the window sill trim to fit into, and then attached the whole window box to the left side of the big board, screwing it on from the bottom. This gave me 8” extra on the right side on which I put another inch square strip to keep the bees out of my bedroom. We also stuffed a washrag into the small space still open.

When I put this box onto our window sill, I could close the window down onto the legs and have an opening for the bees to the outside and a sealed space into the bedroom. The groove under the landing board worked well, but was not sufficient to keep the hive in place. There were several attempts to secure it that did not work, and one that finally did. I had an old hook, but could not find an eye the right size. I also needed some rope to block off the space between the two regular windows when opened slightly for the entrance to the hive box. These two things are what I went out and bought at the hardware store for under \$10.

By the time I had done all this, it was early evening, and I needed to catch the swarm. My first effort with a cereal box funnel to the entrance and sugar water with



*The outside view of the hive box. The matte board is dark inside but white outside. It slides between the hive box and the window of the bedroom. The bottom gap is the space between the floor/landing board and the window sill. The next gap is the entrance for the bees.*



*This is a detail shot that includes the hook and eye that secures the hive upright and the short block of wood that connects it together at the top. These holes drilled for air flow are now covered by the wax of the comb.*

# A WindOH

Dan Long

I love observation hives! Instantly engaging and fascinating to anyone, they provide a literal window into the secret lives of humanity's most important insect. The casual observer and the experienced beekeeper can both learn and enjoy in comfortable convenience. My interest in observation hives started with a volunteer beekeeping gig at our city's nature center. As part of their educational exhibit hall, there is an observation hive that needed attention and ongoing care. I was hooked at once and started looking into designs and construction methods to make my own. I also ended up helping two local schools with their OH's; one associated with the Bee Cause and another with my own design.

My first design was an eight-frame in a 2x4 setup. It's the kind that pivots on the wall and has a tube to the outside through a window gap. It follows some of the specifications provided in the Bonterra plans. Bonterra sells complete OHs or you can purchase plans for a reasonable fee. We keep it on our sun porch. My wife and kids like it almost as much as I do! There's nothing like the fun of watching them bringing in pollen, communicating with each other and seeing the queen laying. It's also educational and helpful with timing with beeyard activities.

There's just one thing about observation hives that really bugs me: having to pick them up and carry them outside to work on them. The one on our sun porch was made with lots of Oak and is probably 100 lbs full. The one at the nature center where I still volunteer is built with durability and public safety in mind. It weighs 150

lbs empty! One of the school OHs is made from thinner pine so it's lighter but it worries me. It's just not that sturdy. In my travels, both real and internet, I found some interesting design ideas to get around this. There's a country store in the nearby mountains that sells honey and other hive products. They keep a hive with glass sides behind a glass wall. It's like a closet but accessed from outside. It's very nice but the bees are too far from the glass to see closely. A beekeeper I found on the web actually converted standard Langstroth deeps and mounted them against a window on his house. Both ideas served as inspiration for my design.

My goals for the new design were as follows. It needed to be easily worked from the outside, function well for a colony to thrive, be economical and have a reasonable percentage of display area to see hive activity. I really liked the idea of using an existing window so that's where the plans began. Why not put the whole thing right on the glass!? I'm very lucky to have my office where I live and the windows are large with undivided glass. Would it be too heavy? Would some heating or cooling stress break the glass? Would it be possible to get good adhesion? A quick trip to the internet revealed a plumber's video in which he tested a little blob of clear silicone holding a hook on a tile wall. The next day he hung a six pack of Guinness from it. I was convinced! What about overwintering? Would the colony be able to cluster properly? How many frames deep should it be? If it was built five frames deep, the weight would pull on the glass more and I might never see the queen or brood at all. In the end, I decided on three frames deep by three frames high. This is also based on experience with the OH over at the nature center. It was originally just five deep frames; three down the front and two behind the bottom frame. It was just not enough





*This is what the comb looks like today.*



*Author's granddaughter. What you are seeing in the top right corner of the hive box is a reflection of the large telescope I have by the window on the adjoining wall.*

Honey B Healthy did not work. A friend, who had just caught the big swarm for his beeyard, happened to come by, and he suggested that I put the hive box on the ground next to the swarm and see if they would just go in. To my utter amazement, they did! I guess it was the sugar water? After dark, my husband and I blocked off the entrance and carried the whole thing to the east facing window in our bedroom. I am happy to report that they were warm and cozy during that 35° night.

We have made some improvements. A piece of matte board and a sewn curtain have replaced the old sheet we hung for dark in the hive. The rope nicely replaces the towel we had stuffed into the bedroom window gap. I am still trying to figure out ventilation, wishing I had drilled holes in the wood before the hive was full.

But mostly it is the bees who have been amazing to watch work.

For four or five days they just huddled in the southern top corner. Then they began making beautiful comb. The precise positioning of the hexagons, a delicate little egg laid in each, guard bees lined at attention, the queen slowly making her way around her domain, waggle dances, new larvae, wax scales on the underside of bees, and clown pants full of pollen are just a few of the things

I've been able to observe at my leisure with a magnifying glass and without my bee bonnet. My six and three-year-old granddaughters were delighted to watch the "ladies" at work without fear of being stung. We are able to open the window at night to change out the sugar water in the feeder. Because the hive is on the second floor of the house, we don't have to worry about a bear getting into it (a big problem in the mountains). Now the comb is full of capped brood, and I hope to watch bees being born in a few days.

There is no way to know at this point if our little experiment will succeed. At the very least, I hope the hive will become strong enough to send out some swarms of its own. Honey is not an object, and there is no way to get the hive box open without destroying the hive. But it has been a great experiment and learning tool with a little group of bees that would have surely died in the cold. If I had a chance to do it again, I would not use reflective double pane glass because photos are so hard to get. I would also drill a series of holes in the wooden spacer strips for more ventilation. Otherwise, it has all worked so very well. Here is to hoping the bees will stay healthy and happy; there is so much more to learn! **BC**

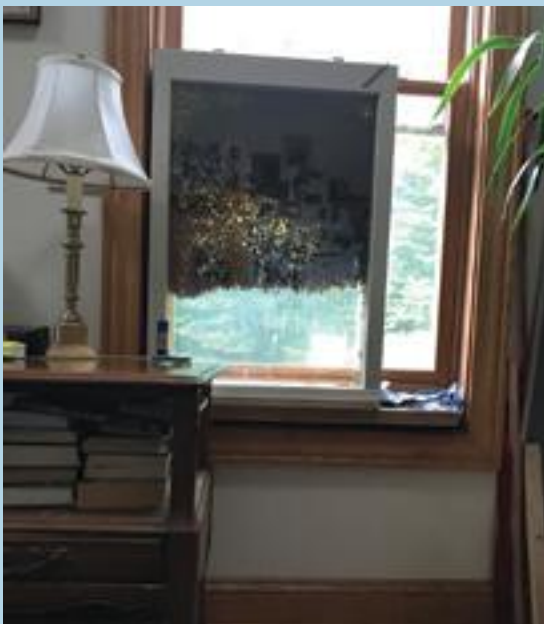

*A sunny morning view.*



*Covered when not being observed.*

**Right For Me?** There are some general considerations for keeping an OH to think about before building or buying your own. First, don't expect it to be a production hive for honey unless you build a huge one like the modified Langstroth hives mentioned in the article. Then you have to consider the location and its suitability for the house and its residents. Will their flight path cross a regular walkway? Is the location practical for working them? If it's a regular indoor OH, will it have to be carried a long distance to work on it? If it's a WindOH, will it overheat or be too cold? Lastly, while it can be done, it probably shouldn't be your only hive. The overall size usually takes some degree of population management. However, I have found that a hive of nine deep frames makes a fairly stable home.

space for a stable colony year round. Luckily it was built with a large box and a false back so I had space to modify it easily to a nine frame in a 3x3 pattern. It's been very stable for a long time now.

So, 3x3 deep frames it was! With help from experienced beeks in an online forum, I chose 4 7/16 inside width. It respects bee space for three frames. The inside dimensions are 29¼ x 19¼; just about right for hanging the frames on ledges. I was worried they would burr up the open space under each ledge but they have left it completely open so far. The bottom is wide enough for a small landing pad on one side and a feeder on the other. The feeder is exposed but it still worked just fine. Maybe in a colder climate it would need a small band heater and insulation since it is isolated from the hive. The top is wider and deeper to make a roof. If it ever needs repair, I will make a wider, deeper roof that slopes away from the window. The overhang of the office roof stops most rain but a blowing thunderstorm can really soak it. On the back is a hinged door. It's a ¾ inch oak frame with foam insulation board inside. The faces of the door are thin plywood. There are three latches to keep the door snug even if there's warping or some propolis buildup. All parts that the bees would contact were taped off and the rest received several coats of polyurethane.

What about Summer? Would it overheat? Again, the

office "wall" of glass would remain relatively comfortable for them and the insulation would help on the other wall. In the end I figured it would be best to have lots of ventilation that could be closed off. Two vents on each side have small fan grills screwed over them. Just the grills; no fans. Plastic tabs slide behind the grills. They can be changed out with screened tabs as more ventilation is needed. A large vent of about ½ of the floor is screened as well. Duct tape covers it well in winter and can't be easily seen from inside.

Installing it turned out to be a breeze. I was worried about holding it level and securely against the glass for 24 hours for the silicone to cure. Then I remembered these windows tilt in! I set up a saw horse at the right level and simply rested the window in a horizontal position. I added a lot of silicone to the oak frame and laid it carefully on the glass. The next day, I took the screen off the window and tilted the pane back into the frame. It worked! That is to say, it worked pretty well. I had no idea glass would sag so much over a short span. Maybe it was the added weight of the oak. So, some spots needed to have a second shot of silicone and others needed some trimming but it worked! I left it empty for a couple of weeks so the silicone would be properly cured and it didn't smell like chemicals. After taking a nuc in my Ulster style observation hive to a lecture (on observation hives of course!), they were installed in their new home. They took to it just fine! Working the WindOH is super-easy, too. It opens right up and is very easy to pull frames out. Treatments are easy, too. No worries about fumes in the building and no hassle carrying it outside.

Between the relative warmth of the office radiating through the glass and the insulation on the door, the colony was able to keep warm enough to overwinter well. We had a pretty mild Winter and this is Georgia so the design might have to be modified up north. I can look in on them any time and have learned so much. Now I just have to figure out how to stop staring at them and get back to work! **BC**



# Beat the heat of summer work...

Splitting and honey harvesting season is here. We will help with your woodenware needs!!



**Keep it simple.**  
Buy painted, ready to go.

- Hive Kit (lid, boxes, frames, bottom) . . . . \$136.85
- Starter Kit (hive plus tools and clothing) . . . 250.25
- Medium Super with frames and foundation . . 39.76
- Deep Hive Body with frames and foundation 46.33
- Economy Nuc with frames (for splits) . . . . 39.04

**Do it yourself**  
Buy unassembled.

- Telescoping Lids . . . . . \$ 15.08
- Inner Covers (raised panel) . . . . . 6.78
- Medium Supers (finger joint) . . . . . 9.65
- Deep Hive Bodies (finger joint) . . . . . 13.33
- Regular Bottom Board . . . . . 11.40
- Frames (any size) . . . . . 0.91
- Economy Nuc without frames . . . . . 18.67

more products and options

volume pricing available

Dealerships welcome!

**BEELINE**  
APIARIES & WOODENWARE

**Rochester, Washington:**  
360-280-5274 beelineofwa@norcell.us

**Pueblo, Colorado:**  
719-250-4005 sales@beelineofcolorado.com

**Mendon, Michigan:**  
269-496-7001 beeline@abcmailbox.net

Call for a free 2017 catalog or download at [www.beelinewoodenware.com/](http://www.beelinewoodenware.com/)!

*Quality & Service Since 1907*

**C.F. Koehnen & Sons, Inc.**

**Queens**  
*Italians & Carniolans*

**Packages**  
*All sized orders for pickup*

*Queen Shipping Supplies*

**C.F. Koehnen & Sons, Inc.**

**ph (530) 891-5216**  
[www.koehnen.com](http://www.koehnen.com)

3131 Highway 45  
Glenn, CA 95943

**fax (530) 934-2613**  
[bees@koehnen.com](mailto:bees@koehnen.com)

# OXALIC. A BETTER WAY?

Jennifer Berry

---

*A new method may be better. Time will tell.*

Several months ago, Randy Oliver started writing about a new application method for oxalic acid (OA) on his Scientific beekeeping website. This particular method mixes OA with food-grade, vegetable glycerin. It is then applied to some sort of matrix (ie. shop towels, cardboard strips) and placed into colonies. Simple and cheap! He derived his information from a beekeeper in Argentina that had been experimenting with this method for several seasons and was showing promising results. So, Randy took it upon himself to test this latest procedure and write about it. This is what beekeepers do. They hear about something that might be working, and they try it, especially if it's promising to kill mites (and cheaper than what is currently available). In a short time Randy was reporting success with the OA mixture. That's when the switch board started lighting up here at the lab. I was getting phone calls and emails asking about how to mix, what to use, when will it be available, where can I get it, why can't this be approved now???

My initial reaction to these inquiries was, whoa folks, let's all take a breather. Yes, Randy has been getting some good results (which he continues to report) however, this has not yet been approved for use in the U.S. and has not been tested on a large scale. Also, Randy's tests were on the West coast (hot and dry). What about our environment, hot and humid? Will it work here on the East coast? Do we need to change the concentration of OA, dosage amounts, delivery methods? Before every beekeeper in the southeast jumped on the OA/glycerin bandwagon (which could have potentially devastating results) I decided we needed to test it on the East coast ASAP. A large field trial to see if 1. Does it kill mites (90%+) in our area, and 2. Is it safe for our bees.

We needed numbers, so I

called several Georgia commercial beekeepers that I knew would be willing to help. Our lab had the colonies but they were already involved in other experiments that would not allow any other interference. I also wanted to enlist the help of a neighboring university, since the trial was going to be a HUGE amount of work, and we were already stretched thin. After a few days, Shearer Turton, Dream Haven Farms (Cordele, Georgia), and Bob Binnie, Blue Ridge Honey Company (Lakemont, Georgia) were both willing to be a part of the study. This was perfect, a trial in South Georgia and one to the North. Plus, Dr. Geoff Williams from Auburn University agreed to collaborate on the study to help his beekeepers in Alabama, who were also eager to know whether this new method would work.

But let me back up a bit. For those of you new to the OA scene, let me give a little background information. Oxalic acid is an organic acid found just about everywhere in the environment, including plants and vegetables. It is bitter to the taste and irritating to the eyes, mouth and skin. It is a natural plant defense against herbivores. It is also found in honey. Since it is not fat soluble (a lipid), it doesn't build up in wax comb. Back in 1957, it was registered as a pesticide (disinfectant/sanitizer), but, by 1994, the renewal of the product registration was cancelled. There are risks involved if you plan to use oxalic acid. Given its caustic effect on the eyes, skin and respiratory system, it's labeled with the highest degree of toxicity, "Category 1." So, as with all pesticides, caution must be taken when handling it.

As of right now, there are three application methods approved for use in honey bee colonies: trickle (dribble), vaporization (sublimation) and spraying. It can be used on existing colonies, packages or

swarms. The two most popular are the trickle and vaporization method. The trickle method is prepared by mixing the 35g of acid with a warm, 1 liter 1:1 sugar-to-water solution. Next, the solution is drawn into a syringe and 5 ml is trickled (scientific term for "dribbly drop") down the seam between each frame and directly onto the bees; the maximum dose is 50 ml per colony (5mls per seam). This method only works when little to no brood is present and temperatures are within the range of 35-55°F. The bees must be in a cluster in order for the OA to be distributed properly, otherwise the solution will not reach every bee, and hence be ineffective. This method works great here in the southeast between Christmas and New Year's, when little to no brood is present. Also, one reason I use this method on my own bees, it works, it is not harmful when used properly and it's fast to apply; about one or two minutes per colony depending on the number of supers. Also, it doesn't matter whether it is a nuc or a full-size hive with a single or multiple brood chamber, but reduction in dosage for smaller colonies obviously.

A few words of caution here. First, only use the solution when it's fresh and more importantly, never use on starving colonies. The bees will consume the mixture since it





Vaporizer.

contains sugar, and this can cause them to die. And of course, you cannot use any of these methods if human consumable honey is present.

Next is the vaporization method, which is only to be used on colonies outdoors. And, whatever you do, do not inhale the vapor! Before you begin to VAP, light a smoker and see which direction the smoke is moving and always stay up wind from the colony being treated. Basically, you use a vaporizer, which is a metal wand with a plate at one end and a cord which connects to a battery at the other end. Oxalic acid is placed on the metal plate. The plate is then slid into the entrance of the colony. The entrance opening and any other cracks and crevices are then sealed with the vaporizer in place to avoid the vapor from escaping. Once connected to a battery, the heat from the plate causes the oxalic crystals to melt and turn into a gas (sublime). The vapor will permeate the hive and when it comes in contact with the mites, it kills them. Each vaporizer is different. Some take only a few minutes to activate the acid, while others take a little longer. Since you don't have to open the colony to treat, this seems to be the easier of the two

methods to implement, especially on cold, rainy days. However, more equipment is required (battery, wand, water, towels and respirator), and it does take longer.

You can also spray (mist) packages or swarms. Over the last few years, we've followed this protocol to ensure that we're starting our research projects with mite-free bees. Once the packages arrived, we placed them in a cool, dark location in the lab for 24 hours for the bees to cluster. Several hours prior to applying the oxalic solution, we spray the bees with a 1:1 sugar solution to fill their honey stomachs and reduce ingestion of the upcoming oxalic treatment. Next, we mix the oxalic acid in a 1:1 sugar water solution and evenly apply the solution to the bees.

Why use oxalic? It works. It has been used for years in Europe. According to numerous studies, it's 90-99% effective at killing the mites with minimal damage to the bees and brood.

Does trickle or vaporization work better? A recent study at Sussex University examined the effectiveness of different doses and application methods on mite and bee mortality. The experiment involved 110 hives. The results showed sublimation (vaporization) was far better at reducing mite populations and showed no increase in bee mortality.

Is Oxalic perfect? No, it only works on phoretic mites, i.e., those mites crawling on the frames or adult bees. The mites breeding under the cappings of the brood cells are unaffected by oxalic administrations, as well as most other miticide products. Therefore, applications are most effective when no brood is present. At beekeeping meetings, when chatting about this product to others, I've heard folks say that they are applying oxalic once-a-week for three weeks during the Summer months. This isn't advisable since it's not very effective and can be

detrimental to the bees. A recent study investigated this approach. Shearer Turton, the beekeeper I mentioned before, did a study where he applied the OA, three times, seven days apart. He had taken alcohol samples prior to the study and then several weeks after the OA sublimation took place. We analyzed the samples at our lab, and at first, this method seemed to be working. Mite loads were down considerably, especially compared to the controls. However, three months later we took alcohol samples again, and the mite populations had rebounded, twice that of their initial numbers. We are hoping to set up another trial next year to test this further, but for now we do not recommend this as a treatment regimen. However, there may be a way to still treat during Summer months.

Several years ago, a group of commercial beekeepers came over from Italy to learn about small hive beetles. The beetles have finally crossed the border and are wreaking havoc, especially in the southern regions. During our discussion, we also talked about *Varroa* control and what beekeepers do in Italy. They said they treated twice-a-year with oxalic acid vapor. They treat once in the winter when colonies are naturally broodless, and once again in the late Summer after inducing an artificial state of broodlessness by caging their queens for 21 days. At first, I thought this was nuts, but, after we talked a bit more, it made sense.

The Italians explained that by August or September, the nectar flows are over and the colonies are about to start producing winter bees. If mite populations are high, then the related virus loads that cause winter mortality will be high as well. Plus, by caging the queen, the foraging population (no longer needed) drops faster, and more colony resources (needed for Winter survival) are conserved. Why maintain a pipeline of replacement bees to sustain a large foraging force after the nectar flow is over? A hive full of bees eats regardless, whether there is work to be done or not. So, interrupting the brood cycle not only knocks down the mites (and the viruses vectored) prior to the Winter bees being reared, but reduces bee populations as well. Fewer mites equals improved health, and fewer bees equals less



UGA lab crew weighing colonies.

food consumed; both circumstances contribute directly to improved winter survival. You can cage the queen for 14 days, release her and then treat on day 21. That way all the mites are now running around without the protection of the wax capping. Yeah, I know that it is work to first cage and later release each queen, but think about the money and work it will save by Winter or next Spring!

Brushy Mountain Bee Farm has been authorized by the EPA to be the sole distributor of OA for use as a miticide on honey bees. What does this mean? Well, for any application of oxalic (in beehives) to be legal, it must have the EPA approved label on it. Brushy is the only distributor registered to use the EPA label. It may seem silly, but it really is there for a reason. If you start searching the internet for OA application in bees, there's a whole host of information out there on recipes for taking 100% OA down (wood bleach) to the 2 or 3% recommended application concentrations. Some advice may be sound, but other advice can be reckless and dangerous to you and your bees. Plus, OA purchased at your local hardware store may be only 95% pure. The material sold through Brushy Mountain Bee Farm is 99% pure. Certainly, you don't want to get hurt or inflict undue stress on your bees. The EPA label assures you of what you are receiving and gives you the applicable instructions to follow so you can safely achieve the results desired without the risks of winging it after watching a YouTube video.

Now back to our regularly scheduled program and the current topic at hand: OA and vegetable glycerin. After much deliberation with EPA (Meredith Laws and Tom Steeger), USDA (David Epstein), USDA-ARS Bee Research Lab (Jay Evans), Randy Oliver, Geoff Williams and myself, we decided on a procedure to test the OA

*UGA and Auburn Crew after two long days in the watermelon patch. From left to right Shearer Turton, Jennifer, Nicholas, Jack, Augusta, Will, Selina, Geoff, and Emily.*



with the food grade vegetable glycerin using shop towels as our delivery matrix. The protocol we used is as follows. There are four treatment groups, each with 50 colonies/group. Two of the groups will receive the shop towels with the OA mixture at different concentrations; one with 12g and the other with 18g. The towels are applied to the top bars in the brood chamber. The other two groups are the controls, one with shop towels and glycerin only and the other with no shop towels at all. Once we were all on the same page it was time to get to work.

Back in June of this year, the UGA Bee Lab crew along with the Auburn University Lab folks took a trip to Cordele, Georgia where Shearer Turton's colonies were located. He had 200 colonies placed in and around a 200-acre watermelon field. If I may elaborate for just a minute. South Georgia, in June, in an open field, in full sun, can be devastatingly hot. Oh, and don't forget about the gnats, they have no problem getting into your veil. Anyway, it took us three days to number, weigh, count bees & brood (colony assessments), collect 300 bees and apply the shop towels. Doing colony assessments gives us beginning bees and brood populations (to test if the treatment

has any detrimental effects on the bees) and the 300 bees we wash with alcohol to give us beginning mite numbers (to test if the product is actually working). After the fourth of July, we traveled back down to Cordele (where it was still hot) and collected the same data as before, along with % of the towels removed. At this point, we have only finished crunching about a ¼ of the data, but the trend is looking good. Mite loads are reduced in the colonies with the OA towels. But, and this is a big BUT, we still have lots of data to finish analyzing. Plus, we need to get the numbers from our Northern trials as well (which we started up the first week in August) before we can clearly determine if this method is working and not hard on our bees, brood and queens.

Next month, I hope to have the data completed from our Southern trial but we won't have numbers yet from our Northern trial. Let's just hope this works, REALLY works, so we the beekeeper, can have a reliable method of mite control that is not harmful to the environment, won't get absorbed into our wax, is easy on our bees and our pocket books, and can be applied in hot weather when other treatments can't due temperatures restrictions. Boy wouldn't this be nice? But before I go, I need to give shout out to Randy Oliver for taking the "OA bull by the horns" and introducing us all to hopefully a whole new way of treating for mites. Because at the end of the day, it is ALL about keeping those mites/viral loads down, if we want to keep our bees alive.

Take care of you and your bees!

*Jennifer Berry is the Research Leader at the University of Georgia Honey Bee Lab.*



*Assessing colonies. Tedious work.*

# WESTERN BEE SUPPLIES

## Traditional Hobby Kit Includes:

- 2 Brood Chambers
- 20 Deep Frames and Plasticell
- 2 6 5/8 Supers
- 20 Shallow Frames and Plasticell
- Plastic Queen Excluder
- Pine Bottom Board
- Pine Cover
- Inner Cover

Assembled: \$300.00 and **FREE SHIPPING!!**

## Make it an **ULTIMATE KIT!**

All the above plus:

- Hooded Zipper Suit
- Lightweight Leather Gloves
- Hive Tool
- Division Board Feeder w/screen
- Wood-Bound Queen Excluder instead of Plastic
- Smoker and fuel
- First Lessons in Beekeeping Book

Assembled: \$475.00 and **FREE SHIPPING!!**

Unassembled: \$360.00 and **FREE SHIPPING!!**

Serving beekeepers worldwide since 1965.



P.O. Box 190  
Polson, MT 59860  
Call toll-free 800-548-8440

Order Online! [www.westernbee.com](http://www.westernbee.com)



\*Free shipping applies to those items denoted as qualifying for free shipping in your order of \$100 or more in the contiguous U.S. Any other items will incur shipping charges. Other conditions may apply; see our online store's homepage for details.



## WE BUY HONEY!

All Floral Varieties  
All Colors and Grades  
Comb honeys



Nancy Burnett  
Honey Buyer  
541 868 2296  
[nancy.burnett@glorybee.com](mailto:nancy.burnett@glorybee.com)

SEND US A SAMPLE!

120 N. SENECA RD | EUGENE, OR 97404 | [GLORYBEE.COM](http://GLORYBEE.COM)

# Beeyard Thoughts, Observations, and Updates

James E. Tew



*Queens – concerns from both my apiary and my wallet.*

**Spoiler Alert:** Long before dawn, I awoke this morning to realize that some of my comments in this piece may irk some queen producers. Certainly, that is not my intention. As a beekeeper with limited time and limited financial resources, I have become more than a bit frustrated about increasingly stringent recommendations concerning queen management and replacement.

In my opinion, and only my opinion, I am reluctant to replace expensive queens with more expensive queens. In recent decades, general queen management procedures have become complicated. Are some of our present queen management recommendations out of date?

I have personal experience producing queens. I understand the labor and frustration of this specialized task. I want good queens, but queens aren't the only thing that can go wrong in a colony. Queen management is only a part of colony management; hence, my conservative attitude in my personal queen management program. What follows are my evolving thoughts.

## Queens and queen management – my personal concerns are crystalizing

Around 14 years of age, I learned to drive using Grandpa's 1952 Dodge pickup. It sported a flathead six cylinder engine, manual three-speed shifter mounted on the steering column, a floor starter, and a simple heater that was installed after manufacture. The heater had one switch – on and off. Nothing else could be adjusted. If things became too hot, turn the heater off. Cold? Turn the heater on. The truck did not always have good brakes, but at an average of 25 miles per hour, stopping mechanisms were not always critically needed. If you can drive a 1952 Dodge pickup, you can drive anything.

The truck was used for everything, but an important job on the farm was hauling hay. The truck's hay load was determined by the grandsons' strength to stack the load. As the grandsons grew and testosterone levels increased, the height of the load approached the ridiculous. At our youthful-hay-load-zenith, as we headed for the barn, weaving along on unlevelled ground, the left front truck wheel slowly left the ground. The truck very, very nearly rolled over. We, forever more, cut the load back.<sup>1</sup> That was enough.

More and more, I am sensing that our queen introduction and management recommendations have

<sup>1</sup>My brother restored the truck and has it to this day. It's still hard to drive.



The restored Dodge. Five grandsons learned to drive using this vehicle. It did NOT look like this back then. Amelia Campbell photo

one wheel in the air and are about to roll over. The traditional load of recommendations, requirements, and costs has been stacked about as high as established queen management practicality allows.

## Queen production in the first years . . .

Ironically, in the early days of queen production, queens were also expensive. Although I have done no historical reviews, I have heard the story of A.I. Root paying a significant sum of money for an Italian queen – delivered from Italy – that escaped its cage and forever more flew away through an open window. I wonder what Mr. Root said at that moment?

As expertise and efficiency increased, queen costs, when compared to annual income levels, dropped over the years. (*I have no numbers to document this previous statement, but I have personally paid \$1.25 for queens - queens that amazingly came with a replacement guarantee.*)

In my pre-*Varroa* years, queens lived and produced for two to five years. As a soon-to-be old beekeeper, it pains me to say, and hear other presenters say, that a queen should probably be replaced every year. Present-day queens cost \$25-\$40 and do not generally come with much of a guarantee. The thought now is that *if she was alive when you got her*, producer obligations have been met. From that concept, the beekeeper must assume that all purchased queens are high quality, properly mated, healthy, and not affected by the caging and shipping process.

*JTew opinion: In a perfect bee world, the health and vitality of a package queen should be confirmed **before** leaving the package supplier. Otherwise, the beekeeper – experienced or inexperienced – drives all the way home only to then discover a dead queen in the queen cage within the package. When releasing packages, time is dear. A dead package queen requires the beekeeper – experienced or inexperienced – to develop a quick plan to get a queen replacement. Could the package and queen come separately? Does anyone know of studies indicating how critical it is to have the queen in the package for the few days of shipping? Does a queen in the shipping package help settle the agitated package bees? If so, could shipping cages, especially the new-styled plastic cages, be modified to allow the queen to be viewed before accepting the package?*

Then the problem really starts – how to introduce her into a colony that is behaviorally designed to destroy any foreign queens. Researchers have conjectured that the colony is trying to prevent being “*coo cooed*” by having a strange queen become the reigning colony monarch.<sup>2</sup> Whatever the fundamental reasons, queen introduction is now as tricky as it was in the very earliest days of queen production. Presently, mistakes and bad luck are much more costly – especially if a new beekeeper is installing an expensive package on foundation.

### **A deep hole . . .**

No doubt, I am digging a deep, complex hole with this “queen-thing” line of thought. I am not always comfortable with the clean, specific recommendations of today.

<sup>2</sup>What’s going on here? Would a colony rather have no queen and pass into oblivion rather than accept a queen unknown to the colony? Is this a genetic defense? Would this hypothetical colony rather die and depend on the progeny of its successful swarms and drones to perpetuate their genetic line? I am far beyond my expertise and know of no science that addresses my thoughts. These comments are only a conversation between you and me, but anthropomorphically, it seems strange that a colony would hostilely reject a new queen that could save their colony. But, bees always have their reasons.

I presently have 17 colonies. Right off the bat, two are not going to survive the Winter. These small, undeveloped colonies are headed by new queens, which cost \$35 each. Both colonies have European foulbrood. *I know. I know. I have mentioned this before.* As I reported last month, antibiotics are not readily available to me any longer, but more importantly, why would I even want this genetic strain in my apiary? I don’t. These two colonies are going to die, and I am out \$70 plus time and travel expenses. As it were, that stings.

In reality, I now have 15 colonies that have a chance to survive the upcoming Winter season. To check the brood nest, I will need to move 25 full deeps of honey weighing about 90# each (just over a ton). I am 69 years old and work alone. Fellow aging beekeepers, let’s not rush into a foolhardy plan. I will check the queens and colony conditions when I pull honey. That needs to happen now, but I am involved in bee meetings and other pressing responsibilities; therefore, it cannot happen for several weeks. Meanwhile, the honey crop also blocks me from most forms of mite treatment. Honestly, I expect the present fifteen queens in my colonies will get a chance at successfully passing the winter. Fall queen replacements will not be coming their way.

### **More complex . . .**

The complexity evolves. Mentally (and financially), I am just a bit more than reluctant to add either Spring or Fall requeening to the list that I should be routinely doing – and I admit that I *should be* requeening (*in a perfect apiarian world*).

But this is what I really feel. Replacement queen costs will be about \$450 plus labor and travel to procure queens – without any guarantee that they will be even good queens – never mind *great* queens. Yet, I will hypothetically be removing functional – but old – queens in order to avoid future supersedure or swarming events (*new queens help reduce both of these issues*). Please give me an apiary moment to get my arms around this costly recommendation that requires a challenging introduction procedure. Good queen stock is only one aspect of good colony management. A great

queen in an otherwise unmanaged colony is wasted money.

### **Swarming cannot be ignored . . .**

If swarming behaviors are not adequately controlled, dearly purchased queen stock simply fly away. Honey bee swarms are a topic and an issue within itself, but not for today. The behavior is difficult to completely prevent or stop once started. It has been frequently stated that a lost swarm represents a lost honey crop. Well, maybe. There are many more factors in play in garnering a honey crop other than swarm control procedures.

But when my colony swarms<sup>3</sup> – and it is not something that I want to happen – at least I get a new queen, and I get a brood cycle disruption that temporarily confounds *Varroa* mites. This queen replacement process does require valuable extra time. The question is begged, “*Do I truly want to pay \$35 for a queen that will be able to produce more bees than I can dependably control or alternatively, be a dud queen without purchase recourse?*”

### **Good grief – what are you trying to say??**

I’m not finished. I still have about 800 words left in this piece but this is a synopsis of what I have tried to say so far.

#### Considerations

- (1) The cost of queens.
- (2) Replacement queen availability for new queen failure
- (3) The expense for yet another queen if the first fails.
- (4) Consideration of all other colony management demands that are made on modern beekeepers and their bees.
- (5) The number of new beekeepers, who are trying to do this queen procedure correctly.

These are some of the issues that have overloaded time-proven recommendations of queen management and replacement.

<sup>3</sup>Should queen-managing beekeepers revisit the mutilation process of clipping one of the queen’s long wings by about one-fifth of its length to prevent long swarm flights? Beekeepers have gotten away from this procedure. Clipping too much could cause supersedure. However, if a \$35 queen’s wing was clipped just enough to prevent her from soaring far away, I could possibly be talked into it – again.

## Queen cells as requeening options . . .

Why are ripe queen cells not more of an option for economical queen replacement?<sup>4</sup> They once were. Beekeepers had cell guards (cell protectors) to protect them from being destroyed by workers. The procedure was reasonably common. Should more beekeepers be taught to produce their own cells rather than to produce or purchase mated queens? Seems sensible to me.

Buying cells is dramatically cheaper, but with issues. It takes longer to get a functional queen to the monarchial position – maybe about 50% longer. Current technology would preclude shipping ripe cells, but I'm sure procedures could be developed. Yet, a single emerged virgin queen cannot be ignored. If cells were in a common shipping container and a single queen emerged, you know what would happen. You have one live queen and a bunch of dead cells.

Many, many years ago, a commercial beekeeper, whose name I have long forgotten, told me that each time he opened a colony, he pressed two ripe queen cells into combs as far from the brood nest as possible – usually in upper supers. The queens quietly emerged in that remote part of the colony and gradually worked their way to the brood nest area. At worst, the cells were destroyed, but he estimated that he requeened about 60% of his colonies without ever finding or evaluating the old queen. Keep in mind; this story was based on personal observations and estimations. However, the beekeeper was insistent that it worked for him.

<sup>4</sup>Cost and time investment would be the primary two reasons for using cells rather than mated queens.

## Candling virgin queens while in mature cells

A ripe cell can be held in front of a bright light to determine if the queen is alive and mobile. Being alive is about all that can be determined. However, the procedure is quick and will prevent wasting time trying to introduce dead queens. Several years ago I posted a YouTube video showing the slight movement of a live queen while still confined in her queen cell. It is posted at: <https://youtu.be/LwlosPG7gn0> on my channel<sup>5</sup>.

## Queen cell protectors . . .

To prevent cells from being destroyed, queen cell protecting devices are still available from bee supply companies. These devices are inexpensive but rarely used. Ironically, I still have one of the old metal ones. The one pictured is only one of many designs that have come and gone.

## Requeening with unmated queens . . .

I don't have a lot of experience introducing unmated queens. In the bee literature, virgin queens are known to be more difficult to introduce, but procedures and success stories abound on the Internet. After all, virgins emerge within the colony, fight amongst themselves, and ultimately one becomes the colony ruler. Is the odor of the foreign unmated queen

<sup>5</sup><https://youtu.be/LwlosPG7gn0>  
Shortened url: <http://tinyurl.com/Candled-Queen>





*An old-styled queen cell protector. The straight wire was meant to be stuck through the wax comb.*

the factor making her difficult to introduce?

Decades ago, I successfully installed unmated queens by shaking a pound or so of nurse bees from a healthy colony into an improvised cage where I dropped a typical queen cage containing an unmated queen. Secondly, I made up a nuc from the same colony and let it sit for a day or so. Into this nucleus colony, I released the caged bees with the unmated queen. Depending on the bees' behavior toward her, sometimes I left the queen caged longer or sometimes I released her immediately. This short period with the caged bees gave the queen time to acquire the nuc's odor. The few times I tried this, it worked.

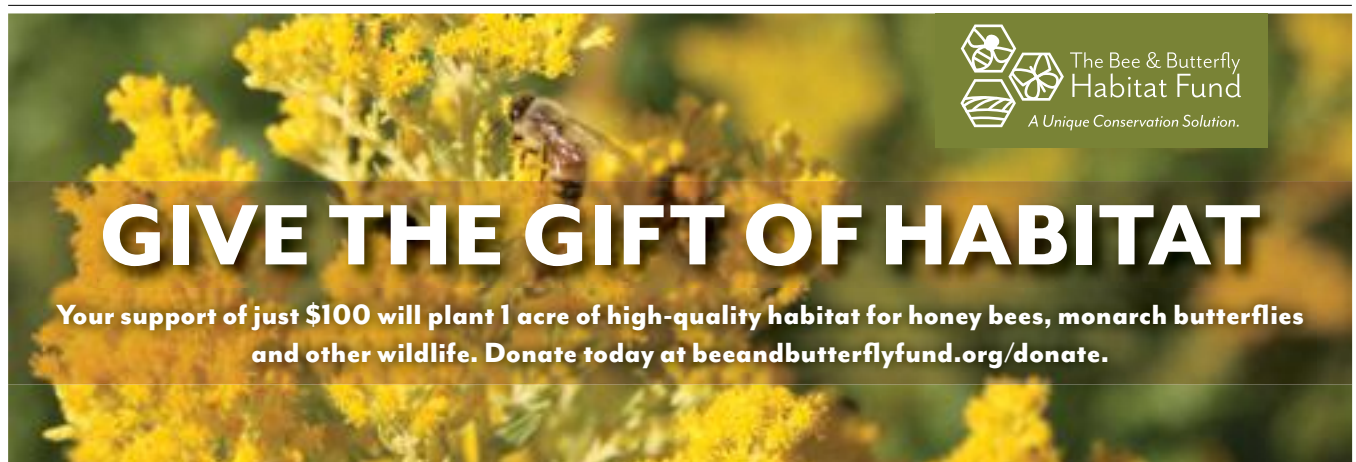
At the time, I was producing queens I had extra unmated queens that had no colony and no future. Essentially, they were available and free of cost to me. That made it a worthwhile procedure for me. Using a nuc to introduce queens, either mated or unmated, is a good idea.



 The Bee & Butterfly Habitat Fund  
A Unique Conservation Solution.

# GIVE THE GIFT OF HABITAT

Your support of just \$100 will plant 1 acre of high-quality habitat for honey bees, monarch butterflies and other wildlife. Donate today at [beandbutterflyfund.org/donate](http://beandbutterflyfund.org/donate).

### Personally speaking . . .

1. Due to price and availability, packages and queen introduction are more demanding than it has been in many, many years.
2. Yes, our queens and possibly our drones do not seem as vibrant as they were 30 years ago. Reasons are unclear.
3. Old techniques of requeening with mature cells or even free-flight unmated queens are possibilities for simplified beekeeper-produced queens.
4. The apiary's colonies should be headed by premier queens. How many and from what producer is still the individual beekeeper's decision.
5. If the beekeeper produces cells or virgins, the grafting stock would come from these high quality queens. The resulting beekeeper-grown queen would potentially result in a good, homegrown utility queen. Maybe excellent or maybe a bummer, but either way, less costly and more readily available.
6. Explore buying queens or cells from local queen-producing specialists. They require less labor but they are

- more costly.
7. Alternatively, do practically nothing for queen management. Depend on natural swarming, splits, spring packages, and occasional purchased queens to keep most of the colonies headed by "youngish" queens.
  8. Lastly and realistically, an option is to pay the price for quality queens, hope they are successful, complain when they are not, but when they become boomer colonies – boast of your achievement. You're out the money, but you could save quite a bit of time.

### Odds and Ends

We should remember this – keeping bees is a remarkably simple procedure. To actually keep bees, one needs a bee colony (swarm) with a queen, proper hive equipment with frames, a smoker, and some kind of hive tool. Control colony pests. That's it. Everything else in the supply catalog is acquired because the beekeeper *wants* it.

Queen production is not much different. You need very young larvae, a sized stick to make queen

cups, a bit of beeswax, a smaller stick to transfer larvae, and a strong queenless colony to grow the larvae for transfer. Good vision helps. Boom – queen cells.

But the beekeeper must commit time and scheduling. To many, it becomes convenient just to buy queens. Your call. But beekeepers do have other options. I wish we talked about these alternative choices more often.

And to be perfectly fair, sometimes a good queen is asked to live in poor housing, taken care of by a, well, let's just say inexperienced beekeeper, and things go south from there. But this is a discussion for another time.

Okay – let me have it. Light up my world. **BC**

Thanks, Jim

---

*Dr. James E. Tew, State Specialist, Beekeeping, The AL Cooperative Extension System, Auburn Univ; Emeritus Faculty, The OH State Univ. [Tewbee2@gmail.com](mailto:Tewbee2@gmail.com); <http://www.onetew.com>; **One Tew Bee** RSS Feed ([www.onetew.com/feed/](http://www.onetew.com/feed/)); <http://www.facebook.com/tewbee2>; @onetewbee Youtube: [www.youtube.com/user/onetewbee/videos](http://www.youtube.com/user/onetewbee/videos)*

## Beeswax Rendering



# A.H. MEYER & SONS INC.

## Cash for Beeswax



**16 Ga. Galvanized  
Pallet Clips**



**Wax Rendering  
Facility**



**Original Fluorescent  
Nets-Made to Order**

Let Us Render Your Beeswax While You Focus On Your Bees!

## [www.ahmeyerandsons.com](http://www.ahmeyerandsons.com)

**P.O. Box 98, Winfred, South Dakota**  
**Phone: (605) 485-2221 or 1-800-841-7952 Fax: (605) 485-2231**

## Polypropylene Hive Bodies



Pricing:	1-4	5-99	100+
9 $\frac{5}{8}$ " with Insulation Panels	\$21.50	\$20.00	\$19.00
9 $\frac{5}{8}$ " w/o Insulation Panels	\$16.75	\$15.25	\$14.25
6 $\frac{5}{8}$ " w/o Insulation Panels	\$14.50	\$13.50	\$13.00

## Hi-Flo Spouts (38mm)

Many Colors available.  
Prices start at  
\$60 per 1000



**New!**



US Pat. Pend.

### NEW Cap n Ladders

- Easier Assembly!
- Easier to fill!
- Easier to clean!

9 $\frac{5}{8}$ " or 6 $\frac{5}{8}$ "	9 $\frac{5}{8}$ " - 2 Frame
1-9 \$1.55	\$ 1.65
10-799 \$1.40	\$ 1.50
800+ \$Call!	\$Call!



### In-Hive Feeders

9 $\frac{5}{8}$ " or 6 $\frac{5}{8}$ "
1-9 \$2.60/ea
10-799 \$2.40/ea
800+ \$ Call !



### 2 Frame Feeders

For 9 $\frac{5}{8}$ "
1-9 \$3.10/ea
10-559 \$2.90/ea
560+ \$ Call !



### Cap n Ladders

9 $\frac{5}{8}$ " or 6 $\frac{5}{8}$ "
1-9 \$1.55/ea
10-799 \$1.40/ea
800+ \$ Call !



**Mother Lode Products**  
15031 Camage Ave.  
Sonora, CA 95370  
Ph: (800) 657-9876

Order online at: [www.motherlodeproducts.com](http://www.motherlodeproducts.com)

*Everything we sell  
is made by us in  
the U.S.A.*



## Happy Halloween!

Where you're "treated" and not "tricked"!



### Woodenware

We are famous for our  
"Long-Life"  
Cypress woodenware.

Now offering Pine  
Woodenware!

Give your bees the most  
comfortable home possible.

### Containers

Various containers for bottling are in  
stock. Glass and plastic, any size you wish.  
Choose from several styles of  
closure.

Other packing supplies available.



### Medication

Chemical and drugs to  
treat many various pests  
and diseases that will  
destroy your hive.

Protect your colony and  
treat to prevent loss.

Call Us today!  
1-800-333-7677

Visit Us online at  
[www.gabees.com](http://www.gabees.com)

# TOP BAR PROTEIN

Wyatt Mangum

*Top Bar hives need a hanger for a protein patty.  
And Small Hive Beetles just love them, too!*

Feeding a pollen substitute helps stimulate brood production during different seasonal conditions.

In my location, Piedmont, VA (mid-Atlantic), the Fall nectar and pollen flow is marginal (from golden rod and aster). Summer rains help to enhance the pollen coming in by early Fall. Conversely, a dry Summer can easily cause a pollen shortage. Rampant seasonal mowing also destroys these resources (see Figure 1). In late Summer and early Fall, the need for pollen is critical. During this time colonies produce their long-lived over-wintering bees needed to sustain the colony until the following Spring.

An alarming scenario would be dry Summer conditions, leading to a severe pollen shortage by the Fall. That would damage the production of long-lived bees, increasing colony mortality in the Winter.



**Figure 1** Death on the left meets life on the right. On the left, excessive mowing has destroyed the wildflower diversity, leaving a green desert of grass. On the right, aster, the tiny snow-white flowers, and goldenrod provide nectar and pollen to honey bees, and other insect communities living on nectar: solitary bees, bumble bees, butterflies and moths, even wasps and flies.

Part of vigilant bee management is planning for pollen shortages. Then in the beginning of their occurrence, the beekeeper can respond rapidly, delivering pollen substitute to the hives, across all apiaries, with an efficient method to maintain colony health.

Frame-hive beekeepers do that. From bee supply companies, they purchase a pollen substitute, prepared as a patty roughly ½-inch thick, sandwiched between two thin papers. A one-pound patty fits snugly between the top and bottom bars of frames in the vertically stacked hive bodies.

Top-bar hive beekeepers need a feeding method too, using the same commercially prepared patties (see Figure 2). However, the top-bar hive requires a hanger to hold the patty, all of which is more complicated compared to just laying the patty on the top bars of a frame hive. In 2015, I began designing patty feeding methods with various wire hangers during dearth conditions.

For the resulting patty feeding design, I paid close attention to the difficulties presented by small hive beetles in the heat of Summer when their invasion pressure is high. I wanted these conditions to be similar to those in the Southeast, as close to the worst case as possible, producing a severe test of my patty feeding design.

In case beekeepers want to change my design, keep these two points in mind:

1) The bees should have continuous access to the maximum surface area of the patty. Therefore, do not put the patty on the floor of the top-bar hive with either a screen or wooden floor. Adult small hive beetles can get up under the patty and produce larvae, which tunnel inside the patty, where the bees cannot evict them (see Figure 3).

2) Be careful about feeding a

colony too much patty at one time. I think about the last part of the patty to be eaten by the bees. How long will that take given the local conditions? If feeding too much patty, the last part could remain for too long in the hive. Consequently, small hive beetle larvae would have more time to foul it. Then the bees will reject the remaining patty, leaving the rest for the beetle reproduction (see Figure 4). From my observations, I came to see pollen substitute as a cryptic source of new beetles if not properly applied.

A starting amount of patty that has worked under my summer time dearth conditions with severe pressure from small hive beetles has been a 1/3 to 2/3 pound. That patty amount is for colonies covering their top-bar combs from the entrance end of the hive extending back for two to three feet long. (I have top-bar hives up to five-feet long, but the colony is smaller than that in the Summer.) As expected, most strong top-bar colonies can consume one-third of a pound of pollen patty quickly, easily in less than a week, especially in a pollen dearth. Surprisingly a few will not. Usually I do not feed a pound of patty at once. Rather, I feed two-thirds of a pound. Then I reevaluate after the



**Figure 2** Ready to insert pollen patties into three top-bar hives. I have removed the hive covers and dealt out the patties (pointed out by the yellow arrows). The patties will hang between the combs from homemade wire hangers. I usually feed pollen patties to about 25 top-bar hives at a time. These “pollen patties” are actually a pollen substitute and do not contain natural pollen. Nevertheless, the slang is to call them pollen patties. These top-bar colonies were finishing a pollination contract, pollinating squash.



**Figure 3** Small hive beetle larvae hidden under a pollen patty on the floor of a hive. Even propping up in a corner, letting the bees get to both sides, did not work. The patty does not have that much structural strength, and it eventually fell over. Then the patty provided a protected refuge for adult small hive beetles, and they began producing larvae. Conditions were “dry” in this situation and there was no slime.

first feeding to see how quickly the bees consumed the patties. On the other hand, if the bees are foraging on some minor Summer source, I will start even strong colonies with 1/3 pound and see how quickly they consume the patties. (I am expecting the consumption to be slower, and overfeeding could provide some of the patty to small hive beetles.)

For smaller colonies, like a nuc, a colony in a one-foot long top-bar hive, or even mating nucs, a pair of colonies in a one-foot long hive separated by a partition, I give them smaller pieces of a patty (much less than 1/3 pound). For the exact patty size, I just estimate it from the cluster size, being careful not to give a small colony too much. The small patties still go into the hangers. With these smaller colonies, I need to make sure the patties stay protected within the clusters for the feeding duration. Otherwise small hive beetles will likely infest them.



**Figure 5** A top-bar observation hive testing a patty feeding method. The miniature wire hanger works like a full-size one. Ideally the patty position is below the honey bands, where there is a little more space between the brood combs. The hive is in a special bee house with 30 single-comb top-bar observation hives, where I study bees and film their behavior.

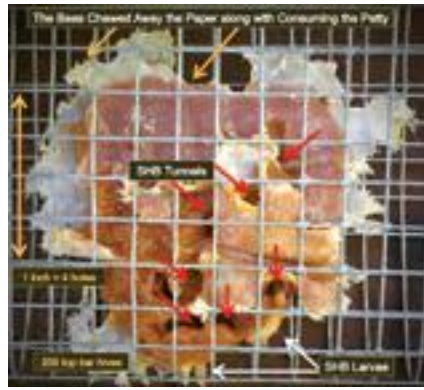

**Figure 4** A small piece of patty infested by small hive beetle larvae. Only about 1½ square inches remained when the other colonies had finished their patties from Summer feeding during intense small hive beetle activity. The two white arrows point to beetle larvae, difficult to discern without magnification. Notice the numerous tunnels in the pollen substitute. Red arrows indicate some of the tunnels.

Before diving into the details of a full-size hanger (holding one-third of a pound patty), Figure 5 shows a miniature version of the hanger design in a single-comb top-bar observation hive with a small piece of patty. The patty resides in the fold of the hardware cloth. The wire grid doubles over, supporting both sides of the patty, ideally with no hiding places for pests. Several rounds of testing in my apiaries showed patties (1/3 pound) needed support on both sides by the wire grids. Otherwise, the patty slouched, or flopped over, forming folds, which became refuges for small hive beetle larvae to begin an infestation.

Notice in the observation hive, the hanger, as a *single* grid of wire, extends up (by the honey band) and protrudes out of the hive as a bent-over tab, holding the patty in place and marking the hanger’s location for its quick recovery. As explained below, I want the patty at the edge of the brood nest. Figure 6 shows that same edge location as a thermal (heat) image.

Here are the directions to construct a full-size hanger (holding 1/3 pound). I use ¼ inch wire hardware cloth, a common mesh size easily found at hardware stores. The cross section of my top-bar hive dictated the hanger’s dimensions. The hanger size should work for similar size top-bar hives; just make a trial hanger and see.

The hanger dimensions aim to lower the patty below a typical

(capped) honey band because lower down there is a little more distance between the combs. Between the upper-capped honey bands, which can bulge, the bees leave a minimum of *one* bee space. Lower down, between the brood part of the combs, which do not bulge, the bees leave *two* bee spaces, for nurse bees working back-to-back. I could have made the hanger to hold the patty even lower because in some situations the patty may still be between extra wide honey bands. Two points against that are: 1) a larger hanger is bulky to handle to pack and transport; 2) As the patty approached the lower edge of the comb, it has less protection by bees against small hive beetles.

Using Figure 7 as a guide, the dimensions of the wire rectangle are 15 and ¾ by four inches (63 by 16 mesh holes). If your wire cutting is off a little bit, don’t fret. It need not be exact. Now make the bottom fold that cradles the patty. With the rectangle lying on its side like in Figure 7, measure six inches (24 mesh holes) from the (lower) bottom and fold it around to the right as shown. When bending the wire grid, it is best to put a little flat stick in the fold so the crease will be wide, helping it to accept the width of the patty as indicated in Figure 8.

Next make the top tab, which sticks out of the hive. Measure 1 and ¼ inches (five holes) from the top of the rectangle. Make a right angle fold by bending that part of the wire to the left as shown in Figure 7. This folded part forms a tab protruding through the top bars, which is bent over and keeps the hanger from slipping down in the hive. The tab also reminds the beekeeper which hives still have

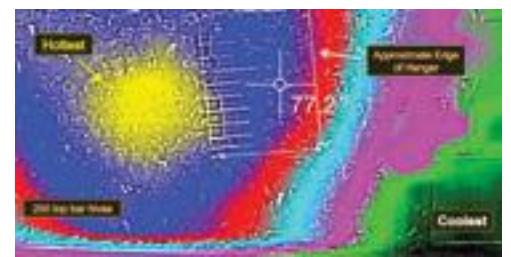

**Figure 6** A close-up thermal image of the observation hive from Figure 5. The pollen patty is at the same location in the color-coded scene (yellow is the hottest and green the coolest). The patty is in the blue, a location of intermediate warmth, near the edge of the brood nest. The patty has plenty of warmth around it from the bee activity, a situation ideal for quick consumption. The 77.2°F is the camera-reported temperature on the outside of the glass, cooler, of course, than inside the hive.



# SAVING BEES, ONE HIVE AT A TIME!



**ORDER  
NOW!**

With its unique blend of ingredients, APICARE improves the health of bee hives by helping honeybees defend themselves against common diseases and pollutants.

**100%  
ORGANIC**

## Natural Bee Care

- Prevents viruses even black queen cell virus
- Aids with removing toxins
- Prevents bacterial and fungal disease
- Aids in digestion and nutrient absorption
- Easy application reduces stress in hives

Contact Justin at: 209.777.8985 or visit: [www.naturalbeecare.com](http://www.naturalbeecare.com)

Call to reserve the best  
**Queens**  
money can buy!

**Wilbanks Apiaries, Inc.**  
Claxton, Georgia

Five Generations of Beekeeping

**912.739.4820**

Our queens score an "A" in NC State University's Queen & Disease Clinic's lab testing for high reproductive quality, size & mating success.

**HIGHEST QUALITY  
Queens  
for 69  
years!**

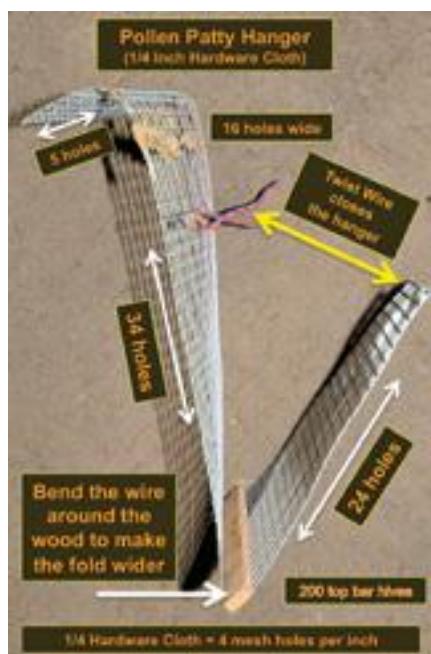

**Figure 7** Bending the wire grid to make the pollen patty hanger. The directions are in the text. The 24-hole side will support the patty vertically against the other side. A vertical patty in the hive environment needs wire on both sides, from top to bottom, for complete support. Otherwise, the patty will slump over and give refuge to small hive beetles. Note the thin red and blue wire. It lines up with the top edge of the wire that will hold the patty, closing the hanger.

hangers in them.

Now make a closure from a scrap of thin wire, which holds the wire grids around the patty. Twist on a short piece, about three inches long of wire to the long side of the hanger,



**Figure 8** Loading a new hanger with a patty in four positions. See the thin red and blue wire about three inches long (position 1) to close the hanger. Locate that closing wire where it will close the end of the folded wire grid as shown in position 2. Fold over the closing wire on the long side of the hanger grid. With a patty loaded in the hanger, press the two wire grids together gently. Hook the closing wire tails through to the opposite grid as shown in position 3. Thread the closing wire tails back through to the other grid and make a snug closure from the other side of the hanger, as shown in position 4. The small pink binding clip at the top of the figure can close the grids too. I cut the one-pound patties approximately into thirds with a box cutter or a large pizza cutter.

even with the top of the other wire grid as shown in Figure 7. Figure 8 shows the twist of wire closing a new hanger as it is loaded with a pollen patty.

A good patty location is adjacent to the brood nest, near where pollen combs should be. I try not to put the hanger in the brood nest, and definitely not next to sealed (pupal) brood. (The hanger might block their emergence.)

Warning. Expect the hanger between the combs to be a snug fit. Gently nudge the bees out of the way with the hanger and close the combs together slowly around the hanger. I leave a wee bit of extra space between the top bars. Do not leave a gap wide enough to let in bees, because it will form another entrance. Expect extra propolis packed into any tiny crack you leave around the wire tab protruding from between the top bars when done with feeding. I just scrape it off, accepting it as a minor annoyance with the method.

One could put in a thin spacer stick to make an extra gap between the combs for the hanger. I have never done that, mainly because I have many hives. A spacer is certainly feasible for a top-bar hive beekeeper with a few hives. (The foundation cleat from a frame or a half of a bottom bar could serve as a spacer. They could be obtained at a bee club meeting. If the honey bands at the top of the adjacent combs are not capped, and a nectar flow is occurring, expect the bees to bulge the honey bands into the extra space, which eventually must be trimmed back when removing the spacer.)

My top-bar hives have the entrances at one end of the hive. The bees situate the brood nest near that end. That arrangement allows rapid access to the brood nest without moving much honey, most of which is towards the back of the hive. I typically insert the hanger a few top bars from the entrance end of the hive right before the beginning of the brood nest (see Figure 9). Replacing hangers is a quick operation too. For feeding numerous top-bar hives, and driving among apiaries, I first load the hangers with patties on my workbench. Then I pack the hangers in containers. Folding the wire tabs the same way makes the hangers easy to stack and pack in the containers for transport. In the



**Figure 9** Feeding another pollen patty in late Summer. This power-house hive was in a three-foot hive and quickly consumed its first patty, which was in the empty hanger on the right. The next patty was the one on the left, propped up for the picture. With bees packing the hive full to the front end, I could certainly feed more than a third of a pound at a time.

apiaries, I work from the containers, placed on the tailgate of the bee truck (see Figure 10).

Scientific investigation of honey bee nutrition has gained importance in recent years, leading to the development of pollen substitutes based on the bees' physiological needs. Frame hive beekeepers have benefited from that research using commercially prepared pollen patties. Now top-bar hive beekeepers have a way to use them too, with little risk of the resource being taken over for small hive beetle reproduction. **BC**

#### Acknowledgments

The author thanks Suzanne Sumner for her comments on the manuscript. Visit: [TBHShyWAM.com](http://TBHShyWAM.com)



**Figure 10** An efficient apiary workflow centered at the tailgate of the bee truck. Here is a storage container with loaded hangers and some extra patties cut into thirds. Returning from the hives, I drop the empty hangers into another container behind the cab of the bee truck.

# Neonicotinoid Pesticides: A Major Problem For Bees, Part I

*The often heard refrain that Varroa is the primary cause of colony losses associated with CCD is simply not supported by the evidence.*

In June 2014 President Obama issued a memorandum creating a Pollinator Health Task Force. Co-chaired by the USDA and the EPA it was charged with creating a national pollinator health strategy to promote the health of pollinators, including honey bees. One of the outcomes of the task force's work was the implementation of a policy by the EPA that among other things, recommended that states and tribes in the U.S. establish Pollinator Protection Plans.

In 2016 the Vermont Legislature passed Act 83 creating a Pollinator Protection Committee. This committee composed of beekeepers, researchers, farmers, pesticide applicators and a government official from the Vermont Department of Agriculture, was charged with a number of responsibilities including evaluating the status of pollinator health in Vermont, as well as the effectiveness of pesticide applicator licensing and regulation. I was privileged to be one of two beekeeper representatives chosen to serve on the ten person committee.

## **Pesticide Lobby at Work**

Unfortunately, I did not discover until after I had agreed to serve, that the Vermont Pollinator Protection Committee was also directed by Act 83, to develop a State pollinator protection plan using the framework and critical elements from the *Association of American Pesticide Control Officials's Pollinator Protection Plan Guidance*. This requirement sent up a huge red flag for me. It appeared that the pesticide lobby had been hard at work trying to ensure that the pollinator protection committee would be boxed-in in such a way that whatever recommendations we came up with would not threaten the pesticide industry's

profits. I wondered to myself, would it be possible to develop a meaningful pollinator protection plan and recommendations while following a guidance framework written by a group that is an integral part of the pesticide industry and actively works on the "development, implementation, and communication of sound public policies and programs related to the sale,

application, transport, and disposal of pesticides?"

Thankfully, while our committee followed the AAPCO framework we did not limit ourselves to only doing so and as a result, were able to put forward some recommendations based on sound science and common sense that has the potential to make the state of Vermont a leader in the area of pollinator protection. Over the course of the next few months, I intend to share many of the things I learned and some of the things the Vermont Pollinator Protection Committee considered when drafting its recommendations for the state of Vermont.

## **Pesticides Rise to the Top**

Upon consideration of the many variables deemed responsible for colony health (nutrition, pathogens, pests, etc.) pesticides quickly rose to the top as the most obvious issue that needed to be grappled with in order to turn the health of pollinators around. *Varroa* mites are the number one scapegoat used by the pesticide industry to divert attention from their toxic products. But *Varroa* were already established in France from 1963 to 1994 without any reports of mass colony deaths in the French literature. It wasn't until the agricultural use of imidacloprid was introduced in 1994 that beekeepers began reporting dramatic increases in colony losses. Similarly *Varroa* was first identified and spread throughout the U.S. in the late 1980's and early 1990's but it wasn't until the mid-2000s that CCD emerged as a major problem. CCD would not have waited some 20 years before becoming a problem if *Varroa* was the true catalyst in creating the disorder.

Since most every colony has mites, or will have them soon, it can be honestly said the *Varroa* is the biggest problem bees and beekeepers have to deal with. However, we can't let this designation distract us from the evidence that strongly suggests that it is actually pesticides, and their lethal and sub-lethal effects, that is primary responsible for the dramatic increase in colony losses that have been associated with CCD over the past 10 years.

When it comes to talking about pesticides, I want to be clear – there is growing evidence that *all pesticides* are likely to have some kind of an effect on honey bees and pollinators. It does not matter if the pesticide we are talking about is an herbicide, fungicide, miticide, or those that are actually designed to kill insects: insecticides. Today's primary focus on the systemic insecticides known as neonicotinoid pesticides, is because these chemicals are the most widely used insecticides in the world.

## **An evolutionary leap in pesticide technology**

It needs to be acknowledged that neonicotinoid insecticides are an evolutionary leap in pesticide



## OTS QUEEN REARING

- 100% Spring Swarm Free
- Free Queens

*"Beekeeping for the Future"*



For more information, visit:  
[www.mdasplitter.com](http://www.mdasplitter.com)  
 INTERNATIONAL MATING NUC, INC © 2016

## BEE POLLEN

Low moisture

10 lbs. -----	\$ 76.00
50 lbs. -----	\$ 335.00
100 lbs. -----	\$ 650.00
250 lbs. ---	\$ 1,575.00
500 lbs. ---	\$ 3,055.00
1000 lbs. -	\$ 5,920.00

FOB Auburn, NE

DRAPER'S  
 SUPER BEE  
 (402) 274 - 3725

Since  
 1997



Your source for double vetted Pacific Northwest bred queens and nucs. Selecting for vigor, disease tolerance, and productivity.

Caucasian and Survivor Stock

[www.oldsolbees.com](http://www.oldsolbees.com)

541.582.2337

**JZ's BZ's**  
**866-559-0525**  
 to order  
**Cups, Cages**  
**& Cell Bars**



## CONTAINER MADNESS

MASSIVE SELECTION OF  
 CONTAINERS AT PRICES THAT  
 CAN'T BE BEAT

**Call Us Today**  
**B&B Honey Farm**  
 5917 Hop Hollow Rd  
 Houston, MN 55940  
 Information Line 507 396 3055 • FAX  
 507 396 4134 • Order Line 800 342 4811  
 email: [b2bhoney@scgroup.co](mailto:b2bhoney@scgroup.co)  
[www.b2bhoneyfarm.com](http://www.b2bhoneyfarm.com)  
*We have fantastic freight rates*

**PLASTIC** - Honey Bears, Skeps, Jugs - 3 lb., 5 lb., Flat Plastic w/Bee, Cylinders, Economy & Classic Cut Comb Boxes

**Glass Bee & Bear**

**Multi-Faceted**

**Hex Jars**

**Dipper Jar**

**Oval Hex**

**Clear & Decorated**

**Honey Mug & Apothecary Jar**

**Sample Jars**

**5 lb., 3 lb. & Pint Jugs**

**Old Fashioned Bail Jars**

**Skeps & Cylinders**

**Glass or Plastic Queenline**

**Flat Plastic w/Embossed Bee**

**GLASS** - Regular & Oval Hex Jars, Classic European Jars, New Glass Bear of Bee, Old Fashioned Bail Jars, Classic Queenline Jars, Apothecary Jars, Honey Acorn Jars, Honey Mugs

## SIMPSON'S BEE SUPPLY

Order 2018 Package Bees

Formic Pro™

Classic Glass & Plastic Jars  
 4.9mm Plastic Drawn Comb Frames  
 4, 8, 16 oz. Muth Jars With Corks  
 Honey Filled Candy \$65/case



15642 Tiger Valley Road  
 Danville, OH 43014

740.599.7914



[cwsimpson@embarqmail.com](mailto:cwsimpson@embarqmail.com)  
[www.simpsonsbeesupply.com](http://www.simpsonsbeesupply.com)

## BJ SHERRIFF

EST. 1968

Specialist makers of  
 fine beekeeping apparel



USA Stockist  
 Sacramento Beekeeping  
[info@sacramentobeekeeping.com](mailto:info@sacramentobeekeeping.com)  
 (916) 451 2337  
[www.sacramentobeekeeping.com](http://www.sacramentobeekeeping.com)



Vermont's Pollinator Protection Committee in action.

technology in several ways. Firstly, since humans are able to metabolize nicotine better than insects, neonicotinoid insecticides are not as harmful to people as most other insecticides, however they are hyper-toxic to bees. Researchers have found that the neonicotinoid insecticide Thiacloprid (trade name Proteus) is twice as toxic to bees as DDT. The most commonly used neonic, Imidacloprid (trade name Gaucho) is 7,000 times as toxic as DDT. And at 10,000 times the toxicity of DDT, Clothianidin (trade name Poncho) is the most toxic of all the neonicotinoids... so far. (Pisa, 2015) It is interesting to note that the use of the least toxic of these insecticides, Thiacloprid, has been voluntarily cancelled in the U.S. by the chemical manufacturer, although it is still in use in other countries.

Organophosphates, which the EPA is working to phase out due to their toxicity to humans, kills insects at a dose of a few parts per million (ppm), but neonicotinoids kill at parts per billion (ppb). However neonics don't just kill insect pests, they also poison many other organisms and contaminate the soil and water. Just to give you an idea of the level of toxicity we are discussing here, one part per billion is equivalent to one teaspoon in 1,000 metric tons of water, roughly the volume of an Olympic swimming pool. Five to 10 teaspoons of clothianidin in an Olympic pool (5-10 ppb) would disable or kill every bee that drank from it.



Varroa mites were around a long time before CCD occurred indicating that something other than Varroa is the primary cause of the dramatic increase in colony losses we have seen over the last decade.

The second evolution leap is that these poisons are systemic. Applied as a seed coating, they are absorbed in the water and are taken up by the roots. The pesticide industry's rationale was that neonics could be used on food crops, with little or no danger to people or non-target organisms like bees, because the chemical stayed inside the crop and never reached the flowers. But that has proven to be absolutely false. Neonics render every part of the plant toxic, from the roots to the flowers including the pollen and nectar, so that the plant in essence becomes a pesticide itself.

Unfortunately, when a canola or corn seed is coated with neonicotinoids, only about three percent of the poison is absorbed into the plant. The balance (about 97 percent) diffuses into the soil. When protected from sunlight, neonics are highly stable and can persist in the soil for three to five years. On clay soil, they can last 19 years. Since soil residues may be present for years following an application (Jones 2014), untreated plants may take up residues of neonicotinoids still present in the soil from previous applications (Bonmatin 2003, 2005).

Neonics are also water-soluble, so they leach into ditches and ponds, streams and rivers. This allows the pesticide to migrate great distances from the fields where the treated seeds are planted and be taken up by wild plants and trees – the very foraging sources that would normally act to dilute, and to some extent mitigate, the toxins in the pollen and nectar that foragers collect from treated and contaminated plants.

Seeds that have been coated with systemic pesticides and are classified as treated articles are the primary vehicles for the introduction of insecticides into our environment. The classification of pesticide coated seeds as treated articles is a loophole that allows the pesticide industry and the EPA to avoid many pesticide regulations. Since the pesticide is not being applied by the farmer in the field, the EPA and almost all the states do not consider the use of a treated article a pesticide application and therefore they are not regulated like pesticides.. – in fact treated articles are not regulated at all, nor is anyone keeping track of the amounts of pesticide introduced into the environment through the application of treated articles. This may change soon in Vermont due to legislation (ACT 99) that grants Vermont the authority to regulate treated articles and treat them like pesticides. As

of this writing I believe Vermont is the only state in the nation that, so far, has given itself this authority.

The third evolutionary leap is that neonics are used prophylactically as a kind of pest insurance policy. Farmers are using pesticide coated seeds year after year whether they have pest problems or not. This practice goes against decades of smart farming where growers only spent money and put resources into using pesticides when they had a verifiable problem and a need existed.

The increasing prophylactic use of neonicotinoids, such as seed coatings, applied before pest damage has occurred represents a shift away from integrated pest management (IPM) and this has been shown to hinder the use of biological control agents. For example, in a recent field study researchers found that the use of thiamethoxam-coated seeds depressed the activity and density of the predatory ground beetle, *Chlaenius tricolor*, thereby partially eliminating predation of crop-damaging slugs, resulting in a 5% reduction in soybean yield (Douglas 2015).

Next month, in Part II of this series, we will look at some of the documented impacts that neonicotinoid pesticides are having on pollinators and wildlife, before moving on to their effects on honey bees themselves. **BC**

Ross Conrad is author of *Natural Beekeeping: Revised and Expanded Second Edition*.

## References

- Bonmatin, J. M., I. Moineau, R. Charvet, M. E. Colin, C. Fleche, and E. R. Bengsch, (2005) *Behaviour of imidacloprid in fields. Toxicity for honey bees*. Environmental Chemistry, edited by E. Lichtfouse, J. Schwarzbauer, and D. Robert, 483–494. Springer, Berlin, Heidelberg.
- Bonmatin, J. M., I. Moineau, R. Charvet, C. Fleche, M. E. Colin, and E. R. Bengsch, (2003) *A LC/APCI-MS/MS method for analysis of imidacloprid in soils, in plants, and in pollens*. Analytical Chemistry 75(9):2027–2033.
- Douglas, M. R., J. R. Rohr, and J. F. Tooker (2015) *Neonicotinoid insecticide travels through a soil food chain, disrupting biological control of non-target pests and decreasing soya bean yield*. Journal of Applied Ecology 52(1):250–260.
- Jones, A., P. Harrington, and G. Turnbull, (2014) *Neonicotinoid concentrations in arable soils after seed treatment applications in preceding years*. Pest Management Science 70(12):1780–1784.
- Pisa, L.W., Amaral-Rogers, V., Belzunces, L.P., Bonmatin, J.M., Downs, C.A., Goulson, D., Kreutzweiser, D.P., Krupke, C., Liess, M., McField, M., Morrissey, C.A., Noome, D.A., Settele, J. Simon-Delso, N., Stark, J.D., Van der Sluijs, J.P., Van Dyck, H., Wiemers, M., (2015) *Effects of neonicotinoids and fipronil on non-target invertebrates*, Environ Sci Pollut Res 22:68–102 DOI 10.1007/s11356-014-3471-x



An organic and noninvasive solution targeting and killing *Varroa* mite infestations, that are killing honey bees, developed by joined forces of, Bee Hive Thermal Industries ([www.beehivethermalindustries.com](http://www.beehivethermalindustries.com)) and OVEN Industries ([www.ovenind.com](http://www.ovenind.com)), experts in temperature control.

You may have heard that “honey bees are in trouble”. There are a few reasons we could list in this dilemma and most experts will most likely agree that the *Varroa* mite is at the top of that list. **Bee Hive Thermal Industries** designed this **Thermal System** utilizing an industrial grade heater blanket and electronic controls which are easily installed and removed from the hive. The end goal of the product is to raise the temperature of the hive to a programmed temperature, killing the mites without harming the bees based on studies done in Europe. To see the game changing product in action, click the link and view the video. <https://youtu.be/D314G2Ws91o>

In the fight against today's *Varroa* mites, beekeepers are often, if not always, resorting to pesticides as the solution. Bees have many other predators and hardships to endure, including weather related issues such as cold temperatures, moisture and diseases. The effect of the *Varroa* on the overall colony is paralyzing to both general activity and honey production within the hive. This revolutionary product is showing positive results in killing and controlling mites and hive beetles, with only a few applications annually.

Bee Hive Thermal Industries, located in beautiful Pageland, SC, is recognized as a global leader in the design, development and distribution of organically suitable products for the bee industry globally. The company strives daily to provide unique and safe solutions for beekeepers everywhere, providing them with high quality, value and reliability. Caring for our bees is very important to the mission of **Bee Hive Thermal Industries**. Visit our website [www.beehivethermalindustries.com](http://www.beehivethermalindustries.com)

**\*\*Entrepreneurs Needed For Sales & Support\*\***

## Bee Hive Thermal Industries, Breaking News, Saving Honey Bees Organically

Lynn Williams  
803.504.9313

[lynn@beehivethermalindustries.com](mailto:lynn@beehivethermalindustries.com)



# Honey Jumbles

Peter Sieling



In the late nineteenth century, before freezers and food preservatives, bakers in some of the metropolitan areas produced Honey Jumbles, a delicious snack that improved with age. One company in Wisconsin used ten tons of honey a year in their manufacture. Beekeepers wanted the secret formula. Somehow, Dr. C.C. Miller, a regular columnist in *Gleanings in Bee Culture*, acquired the recipe and shared it in his December 15, 1896 *Stray Straws* Column:

#### Honey Jumbles:

Flour 196 lbs, lard 10 lbs, honey 12 gallons, molasses, three gallons, carbonate of soda, four lbs, salt



one lb, water three gallons, vanilla extract, one pint.

Ernest Root, the editor of *Gleanings*, considered this recipe a “real acquisition, if it was actually the real formula.” Writers and editors of bee magazines aren’t necessarily expert cooks. Dr. Miller set his “women-folks” to the task of reducing the formula for the home kitchen.

The result was a great success. Dr. Miller sent some samples to Ernest Root, who pronounced them as good as or better than the commercial product. More a chemist than a cook, Ernest felt the proportions should be exact. He republished the recipe in January 1896 using pounds, ounces and gills as the units of measurement.

In the February issue of *Gleanings*, Ernest further reduced the recipe and converted it to common kitchen measures. In the March issue, responding to a reader’s question, he finally explained how you actually make Honey Jumbles.

Honey Jumbles were such a big deal I had to try them. Ernest’s final directions still left out details like baking temperature and time, but that was not unusual for his day.

Wood and coal stoves ruled the kitchen in 1896, so precise temperature and cooking time were not usually a part of recipes. The *People’s Cook Book* from 1882 tells cookie bakers to “roll thin and bake quickly.” The 1905 *Monarch Cookbook*

gives similarly vague cooking directions. “Bake on a buttered tin sheet”, “cook until done”, and “bake in moderate oven” are the types of directions given. It was assumed you knew how to use a wood fired oven without a thermostat, because that was how everyone cooked.

I enlisted my own “woman-folk” for help with the recipe. As a 30 year veteran of cooking with both wood fired and modern gas ovens, Nancy could convert an old recipe to fit a modern kitchen. She threw me out of the kitchen and whipped up a batch. When they came steaming out of the oven, I could hardly wait to try them.

How did they taste? Good, but not exciting. The original Honey Jumbles are simple cookies, made without spices, chocolate chips, nuts, and other added ingredients people enjoy today. The original recipe is worth trying for a taste that was appreciated



by your ancestors. We were able to improve upon it significantly by adding a few spices and either rolling them in sugar before baking or adding some frosting.

Honey Jumbles stayed fresh tasting in an era before preservatives and refrigeration were available. Ours lasted for two months and tasted as good as they did on the first day. Ernest Root must have saved some of the original Honey Jumbles that Dr. Miller sent him. In December of 1910, he said those Jumbles tasted as good as fresh after 12 years.

You can find recipes and images of Honey Jumbles online. They are usually lozenge or cookie shaped and frosted. The originals had a hole in the center, like a flat doughnut. Make a batch for your next bee club meeting. Maybe they'll make you chairperson of the refreshment committee. **BC**

*Peter Sieling keeps his bees, builds things and bakes at his home in Bath, NY.*

*Original Honey Jumble Recipe for the modern kitchen*

- 1T shortening
- 2/3 C honey
- 1/4C molasses
- 1 t baking soda
- ½ t salt
- 1 t vanilla
- ¼ C water
- 2 2/3 C flour, extra if needed

Melt shortening and blend with honey and molasses. Add half the flour along with the other dry ingredients. Stir in water and vanilla. When thoroughly mixed, add the remaining flour. If the dough is too sticky to handle, add more flour until you can handle it with floured hands and roll it into balls. Compress balls, and place on a greased cookie sheet. Bake at 350 for 10-15 minutes.

For spiced Honey Jumbles, add: ½ t cinnamon, 1 t ginger, and 1/8 t cloves.

You can also roll them in sugar or cinnamon sugar before baking or add your choice of icing.



Visualize  
Whirled  
Peas





# STOP

## PREDATORS

### IN THEIR TRACKS

**To Protect Your Property From Night Predator Animals**

Nite•Guard Solar® has been proven effective in repelling predator animals for the past 19 years. Nite•Guard Solar attacks the deepest most primal fear of night animals, that of being discovered. At sunset, Nite•Guard begins to flash and continues until sunrise. The simple but effective fact is that a "flash of light" is sensed as an eye and becomes an immediate threat to the most ferocious night animals and they will run away.

SATISFACTION  
**GUARANTEED**  
or your money back!

#1

NITE•GUARD

Solar

For information & videos log on to:

niteguard.com • 1.800.328.6647

PO Box 274 • Princeton, MN 55371

\$19.95

EACH

FREE SHIPPING  
When You Buy 4 Lights or More

PROMO CODE  
4FREE

#1  
 The World's  
 Top Selling  
 Solar Powered  
 Security System

DON'T BE FOOLED BY  
COPY CATS

**Nite•Guard Repellent Tape**

Keeps predators away during the daylight hours

\$14.95

Per Roll

LIKE US ON FACEBOOK

# All The BUZZZ in...

## Hello Friends,

Fall is full of the fruits of our flying friends. Thank our pollinators everytime you eat pumpkins or squash.

Bee B. Queen

Bee B. Queen Challenge

Send me a game you created using your bee bot.



Hopeful Elmatti, 7, FL



## A Poem and Picture

Me and my brother walk on the street.  
We smell honey so sweet.

Ian Elmatti, 6, FL

## Bee Bots

Create a simple, inexpensive honey bee robot using a vibrating toothbrush.

### You Will Need

- battery operated vibrating toothbrush
- fingernail brush
- index card
- markers
- chenille stick
- tissue paper
- scissors
- 2 rubber bands



### Directions

#### Make a Paper Bee

1. Body. Cut an index card in the shape of a bee body about 3 inches long. Color strips on the abdomen to represent the segments. Draw two compound eyes. (Fig. 1)
2. Legs. Cut a chenille stick in thirds. Twist together in the center to form the legs. Bend each leg to form an "L" shape. Tape them to the underside of the paper bee. (Fig. 2.)
3. Wings. Cut and glue tissue paper wings to the body.



### Tips:

- Buy the least expensive vibrating tooth brush available at drug and grocery stores. It works better to have a vibrating handle not just a vibrating brush. Some electric toothbrushes have detachable brushes you can remove.
- Cut the bristles on one the short sides of the nail brush at an angle to help with the movement.

#### Make the Bee Bot

1. Use a rubber band to attach the paper bee on the top of the brush part of the toothbrush. (Fig. 3)
2. Connect the nail brush to the toothbrush handle using a rubber band. (Fig. 4)
3. Place the bee bot on a smooth surface. Turn on the toothbrush and watch it go.
4. Experiment creating different flight paths by adjusting the direction and placement of the nail brush.



Fig. 1

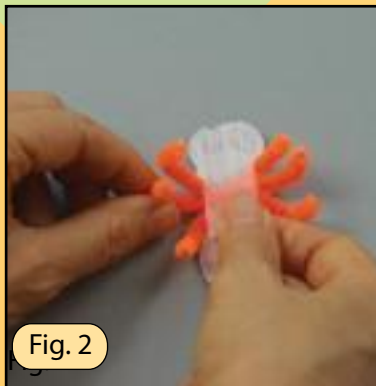

Fig. 2



Fig. 3

# ... Bee kid's corner

Produced by Kim Lehman -www.kim.lehman.com

www.beeeculture.com

October 2017

## Bee Buddy

Meet Zoe Brown, age 9 from Massachusetts . It all started when Zoe's dad began keeping bees. It wasn't long before she began helping him in the bee yard. Zoe says, "I didn't like bees at all at first because I hate bugs, but over time, I got used to them. To me, it's really cool how they collect honey and pollen!"



As a natural leader, Zoe started a community garden with an after-school group. They planted nectar and pollen producing flowers that attract bees. During the school year, Zoe enjoys participating in track and tennis. Keep up the great work Zoe!

## Become a Bee Buddy

Send two self addressed stamped envelopes and the following information to: Bee Buddies, PO Box 2743, Austin, TX 78768.

<b>Name</b>
<b>Address</b>
<b>Age</b>
<b>BirthDay Month</b>
<b>E-mail (optional)</b>



We will send you a membership card, a prize and a birthday

Send all questions, photos and artwork to: [beebuddiesclub@gmail.com](mailto:beebuddiesclub@gmail.com) or mail to the above address.



## Bee Bot Experiments

- What happens when you turn the nail brush sideways or move the toothbrush to the back or front of the nailbrush?
- What surfaces provide the fastest flight?
- Learn more about the research and design of RoboBees based out of Harvard's School of Engineering and Applied Sciences.

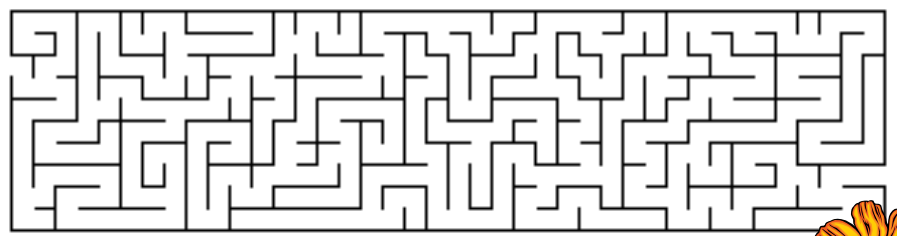

Help the bee find the flowers.



## Science and Bee Robots

Scientists and engineers are studying the way insect see and fly to create very small robots for use in pollination, emergency rescues, exploring hazardous areas, weather mapping, traffic monitoring along with many more applications.

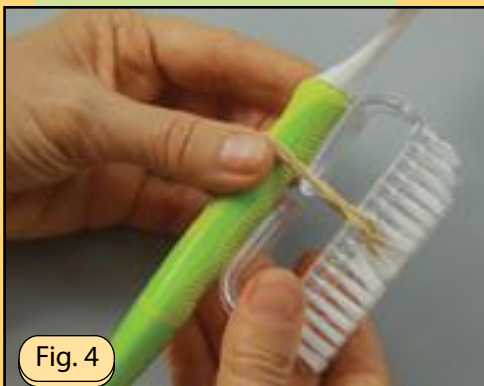

Fig. 4



## Bee Bot Pollination Game

Place paper flowers on a smooth floor. Turn on your bee bot. Count how many flowers the bee bot touches. Better yet, make up your own bee bot game!

**Pierce**  
Beekeeping Equipment  
Made in the USA



**Electric Uncapping Knife**



**Uncapping Tub Kit**

**2 Year Warranty!**

For A Dealer Near You:  
**(714)447-3855**

Dealer Inquiries Welcome  
[www.PierceBeekeeping.com](http://www.PierceBeekeeping.com)

**nozevit™ Plus**

"All Natural Honeybee Food Supplement"  
Your partner in helping maintain the intestinal Well-Being and Integrity of your honeybee Colonies



Helps maintain healthy colonies.

Promotes productivity of honeybees.

Treating your honeybees the natural way.

as little as **32¢** per use.

Available at:  
**eKoBeekeeping.com**  
**Dadant & Sons**  
Or ask your local beekeeping supply store.

Brought to you by **Complete Bee**  
"All Natural - All The Time"



The leading honey & food lab since 1954  
ISO Accredited 17025

Adulteration | Traceability | Residues | Authenticity

- Antibiotics (Fluoroquinolone, Nitrofurans, Chloramphenicol, Carbendazim)
- Aflatoxin Analysis – Chemical Analysis
  - Microbiological Analysis
- Pesticide Analysis – Pyrrolizidine Analysis
- Pollen Analysis – specific testing for honey
- NMR Honey Profiling – world's largest database

[www.qsi-q3.de](http://www.qsi-q3.de)

Tentamus Group Illinois  
Lauren Fleming | [lauren.fleming@tentamus.com](mailto:lauren.fleming@tentamus.com) | (630) 488-7434  
Quality Services International GmbH, QSI | Bremen | Germany  
[info@qsi-q3.de](mailto:info@qsi-q3.de) | +49(0)421-5066070

Columbia Food Laboratories | Portland, Oregon  
[info@columbiafoodlab.com](mailto:info@columbiafoodlab.com) | (503) 895-2287



**Thymol.net**

- Buy Online At [www.Thymol.net](http://www.Thymol.net)
- 100% Pure Food Grade Thymol Crystals
- Free Shipping In The Continental US!



1 - 4 lbs .....	\$24.00/lb
5 - 9 lbs .....	\$18.00/lb
10 - 24 lbs .....	\$16.00/lb
25 - 49 lbs .....	\$14.00/lb
50+ lbs.....	\$12.00/lb

Common Uses: Thymol naturally occurs in many essential oils. It is used as a flavorant in many foods, candies and personal care products.

**Thymol.net**

# You Missed It!

Ann Harman

No matter where you live in the U.S. you had a big regional bee conference in your area this Summer. You either went somewhere else for a vacation or stayed home. Those of you in the East could have attended the Eastern Apicultural Society (EAS), the oldest one, started in 1955. The middle of the country has the Heartland Apicultural Society (HAS) while out West there is the Western Apicultural Society (WAS).

Membership in these is not restricted so that you will find beekeepers being members of two or even all three. Both HAS and WAS were started with the encouragement of EAS so that beneficial beekeeping information could be given to beekeepers without their incurring very long distance travel. As with EAS, both HAS and WAS include the Canadian provinces north of their region.

The conference programs of all three regionals are similar. Their conference meeting place changes each year, keeping within the territory designated. In general there will be presentations that are suitable for all levels of expertise, from beginners on up to experienced beekeepers. The speakers will be researchers, local or regional beekeepers, apiary inspectors, and other specialists in the world of beekeeping. How-to-do-it workshops provide all beekeepers a chance to learn a skill or craft. Local beekeepers provide hives for open-hive demonstrations. Sometimes tours are offered, not only beekeeper-oriented but also for local places of interest. Banquets, barbecues and other social events bring beekeepers together where they can share their successes and catastrophes. The vendors' displays feature the large commercial bee equipment suppliers, smaller local ones as well as local crafters. A business meeting is

usually held for officer elections and to choose future meeting sites.

Now let's take a more detailed look at what you missed. We'll start with the oldest one, EAS. Its region covers all the states east of the Mississippi River and includes the Canadian Provinces of Ontario, Quebec and the Canadian Maritimes. However people from all over the U.S and sometimes from around the world attend. This year the host state was Delaware for the third time there. The Conference Center of the University of Delaware was the site of all the activities. In addition, the university's apiary was used for open-hive work.



At the university, Dr. Deb Delaney, Professor of Entomology and Applied Ecology, conducts honey bee research and helped coordinate the EAS event held there from July 31 through August 4.

The EAS Short Course is divided into levels, Beginner, Intermediate and Advanced but those who attend can go to lectures at any level. For example, the Beginner level included Bee Biology and hive inspections in the apiary. In the Intermediate level the topic of nucs and their uses was presented. In the Advanced, beekeepers could learn microscopy and dissection of bees. The problems of *Varroa* mites were included in all levels. Open-hive work in the apiary was an important part of the Beginner and Intermediate levels.

The conference itself, beginning on Wednesday and continued Thursday and Friday, featured two keynote speakers to start the day. After these two presentations the rest of the morning was split into five separate sections where you could take your choice of topics and speakers. Apiary time was scheduled in the afternoon as well as several presentations. Evening programs,

after dinner, were for entertainment. Since Delaware has several famous botanical gardens, afternoon tours of these were scheduled. Programs for children were given on two days. You could enjoy a special evening visit to Delaware's only meadery.

EAS gives several awards: the Hambleton Award for an outstanding bee scientist, the Student Award for an exceptional graduate student, The Roger A. Morse Award for Teaching/Extension/Regulatory activity, the Divilbiss Award for public outreach. In addition a fund was created for a stipend to a honey bee researcher. The EAS Master Beekeeper program, begun in 1981, is a series of four exams: written, lab, field and oral. These exams are given early in the week. The EAS Honey Show has been held for many years at the conference and brings in entries representing the many honeys of the East Coast.

Now let's see what you missed this year. Presentations by Jennifer Berry, Michael Palmer, Tom Seeley, Marla Spivak, Jay Evans (USDA), Jim Tew, Tammy Horn Porter, Bart Smith, Maryann Frazer, Kim Flottum, Vince Aloyo, and a number of others. Entertainment by Cliff Sunflower with his Dancing With The Bees, Bee



**COWEN**  
MANUFACTURING CO. INC.

**Save Money**  
**Pumps and Spinners**

2" Gear  
3" Progressive Cavity  
Cappings Spinner

**Buy Cowen**

[www.cowenmfg.com](http://www.cowenmfg.com) 800-257-2894

**Hive Tracks**  
KNOW YOUR BEES

- iOS And Android Mobile Apps Now Available
- Record Inspections With The Touch Of A Button
- Track The Health Of Your Hives

Download The Hive Tracks iOS App In The iTunes App Store  
And Receive Your First 14 Days Free!  
Signup At [www.HiveTracks.com](http://www.HiveTracks.com) Today!

*"Honeybees are the backbone of agriculture"*

**STRACHAN**  
**APIARIES INC.**

New World Carniolan Bees & Queens 

We select for:

- Hygienic Behavior
- Honey production
- Mite resistance
- Gentleness

2522 Tierra Buena Road Phone: (530) 674-3881  
Yuba City, CA  
95993-9654 Fax: (530) 674-5802  
[www.strachanbees.com](http://www.strachanbees.com) [orders@strachanbees.com](mailto:orders@strachanbees.com)

**Now accepting orders for 2018**

**OxaVap.com**  
*Your Source for Oxalic Acid Vaporizers*

Don't Let Mites Kill Your Bees,  
**Vaporize** Then  
With an **OxaVap Vaporizer!**

Featuring the Varroa Vaporizer  
acknowledged in Scientific Beekeeping as  
"One of the highest ranked models!"  
The only good mite is a "Vaporized" one!

Jeopardy with Howland Blackiston, a honey tasting workshop with Marina Marchese, Sarah Red-Laird and all the kids, including a session with deaf children, all topped off with Jim Tew as the banquet speaker. What a week!

Let's cross the Mississippi River into the territory of the Heartland Apicultural Society (HAS). Although this region could include those states west of the Mississippi River to the border of Colorado and also the Canadian Province of Manitoba, conferences have usually been in Indiana, Illinois, Missouri and Michigan, as well as a few in Kentucky and Tennessee. This year the 15<sup>th</sup> annual conference was held July 13 through 15 at the University of Southern Indiana.

Heartland Apicultural Society



Discovering the program and activities on the website was difficult.

Since the conference actually started early on Thursday morning, many beekeepers came on Wednesday. HAS planned a movie night for those who arrived on Wednesday. The program began each day with a speaker in the main meeting hall for all attendees. After a short break the beekeepers had quite a few choices of programs. The beginning beekeepers had their special program each day with time in the apiary for open-hive work.

The concurrent breakout sessions each day featured two apiary sessions – one of those especially for beginners. Four separate tracks were suitable for all beekeepers. A special Lab session was offered only in the morning. An Advanced track and a Queen Rearing session completed the day's choices. Some of the sessions were repeated during the three days. The Thursday Lab session topic was nosema and the Friday one was anatomy. Queen rearing sessions also had apiary times. The topics in the breakout sessions covered just about everything to do with bees and beekeeping, including apitherapy, planting for bees and top bar hives.

HAS also has a honey show similar to that of EAS. In addition this year a special Art Exhibit was held for everyone's enjoyment. The art items were brought by those attending the conference. Paintings, drawings, photographs, wax art, encaustic painting, and even antique items,

all with bee and beekeeping themes, were accepted for display. Craft items were not included.

On Thursday night, after dinner, an ice cream social gave everyone a chance to talk – about bees of course. Friday night everyone enjoyed “a good old BBQ.” The conference ended Friday afternoon at 4:00.

Lets see what you missed here. Presentations by Ernesto Guzman, Jeff Harris, Zach Huang, Tom Webster, Greg Hunt, Jim Tew, John Skinner, Jerry Hayes and Tammy Horn Porter. And you also missed the Art Show, the ice cream and the BBQ

It's time to move to the Western Apicultural Society's annual conference. This conference marked their 40<sup>th</sup> year. The territory WAS covers are the states of Arizona, California, Colorado, Hawaii, Idaho, Montana, New Mexico, Oregon, Utah, Washington and Wyoming, as well as the provinces of Alberta, British Columbia, Saskatchewan and the Yukon. That is a large area with quite a range of climates!

The chosen site this year was the University of California at Davis where much bee research is conducted. Dates were September 5-8. The conference met for the main lectures at the ARC ballroom with the vendors in the adjoining part. Events were also held at the Bee Biology Facility and the Bee Haven Garden.

Tuesday evening, the 5<sup>th</sup>, there was the Bee Buzz Social in the evening. The conference was to begin Wednesday morning with a presentation by Serge Labesque on the Seasonal Honey Bee Colony Population Cycle, but a family issue caused Serge to miss the program, so Amina Harris, Director of the UC Davis Honey and Pollination Center at the Robert Mondavi Institute stepped in. Her topic was Moderated Honey Tasting.

On Wednesday afternoon the beekeepers were offered a choice: a series of tours or a three-part Short Course by Dr. Larry Connor on Keeping Your Bees Alive and Growing, for an extra charge. The four tours were organized with transportation so that the attendees

would visit all four. The tours were: (1) the Mann Lake warehouse and showroom plus their sugar syrup blending facility, (2) the Z Specialty Food Company that sells the Moon Shine Honey Company's honey and hive products, (3) the UC Davis native bee habitat restoration project and (4) the Häagen Dazs Bee Garden.

Mini-sessions were given at the Bee Biology Facility and the garden on various topics such as preparing bee samples for molecular studies, selecting plants for bees, and types of beehives that contained colonies.

Thursday morning and all of Friday presentations were given in the ARC Ballroom. Topics included *Varroa*, African honey bees (they are in California and other WAS states), native bees, top bar hive management and queens. Rod Scarlet, the Executive Director of the Canadian Honey Council, presented Topics of Interest from Canada.

The banquet was held on Friday evening marking the close of the conference. Two awards were given: one for Outstanding Service to Beekeeping (including U.S. and Canada) and a local award, the Thurber Award for Inventiveness.

Let's see what you missed at UC Davis. Elina Niño, Randy Oliver, Eric Mussen, Kim Flottum, Larry Connor, Robbin Thorp (native bees and bumble bees), Rod Scarlet of Canada, honey tasting, the tours of Wednesday and the demonstrations at the Bee Biology Facility and Bee Haven Garden.

Now go and attend your local club meetings. Maybe someone there attended a regional conference and can bring you up to date. Now is the time to start planning to attend one of these conferences in 2018! **BC**

*Ann Harman travels to lots of meetings throughout the year. She was in Medina, Ohio in September. Watch for her, you never know where she'll show up.*



# BIGGER PICTURE

Jessica Louque

## Bee Equipment Take II

In our line of work, we have some really odd issues sometimes. Walking around in public with a swollen or black eye because you had an encounter with an angry bee can lead to stares or confused questions. Smelling like smoke and covered in sweat picking your kids up from school (also in camo pants and dirty t-shirts) can cause a different set of questions for parents who don't know what you do for a living. As is common with beekeepers, we *may* have a slight hoarding tendency with bee equipment, causing the delivery guys to wonder why your house looks like it should be packed up and moved to the dumpster. To be fair with this, hive boxes sitting around make it harder to mow, but we leave some patches to grow up for our birds to hide from predators – or at least, that's our excuse. For bee equipment, most of the time you use it until it falls apart, but a lot of times we have an excessive surplus that's not reusable for a variety of uncommon reasons, such as being used in a study or pollinating in a field that had a spray incident. For these additional pieces of equipment, I can't bring myself to just throw them away, but I know they shouldn't be

used again with bees. This is when you start getting creative with your bee equipment usage to give it a second life.

As most people who even vaguely know me would realize, I love shoes, books, and birds. There are now maybe 14 hive boxes in the bedroom holding shoes and some clothes. Our house is around 70 years old and closet space was apparently optional at the time of construction. There are five closets in the house and none are more than two feet deep or four feet wide (that's the biggest one). It would be pushing the measurements to say the linen closet was 2' x 2' and nowhere near big enough to hold towels and sheets for six people. Hive boxes make pretty good stackable shelving though, and can usually fit long-ways on the ground in the closets to add vertical space. One eight-frame box sits underneath my monitor as a computer stand. Hive bodies can also be turned to accommodate books of varying sizes, making bookshelves a popular option for reuse. For books in particular, a shelf liner is a necessity because wax or propolis is not necessarily the best thing to have on the bottom of a shelf for book bottoms. After overuse

of hive equipment in the house, you begin to look for places to use them outside.

Three hive boxes turned sideways can make a nice little "tunnel" where you attach a hook to the middle box at the top to hang a chicken feeder. It makes a good rainy day shelter for an additional feeder, and keeps the chickens from knocking too much of the food out since it's only accessible on two sides. The height can also keep the chickens from getting into the top of the feeder (a favorite place to stay for some of them). Stacking the hives in a sort of stairstep-fashion can create a fun roosting playhouse for your birds as well. For the turkeys, when they were younger they could fit through hive boxes, but now they use them for a perch. Marshall is a broad breasted white (an accident on my part) and besides the horrible wobble walk, he/she can't really perch well from the weird angle of his drumstick legs on the sides of his/her body. I thought Marshall was a boy but now I am thinking he might be a girl, hence the he/she above. The hive stands are the perfect width for Marshall to rest comfortably without fear of falling off, and Scooter (I think a broad breasted bronze but he doesn't have the same horrible leg issues as Marshall) seems to like sitting on the boxes more than sitting on a perch.

The current project is a quail pen made from hive equipment. I am fairly sure this is going to be a never ending building game, but it's at least functional. For any of you that might be interested in raising pheasants or quail, this might be a good option for you in the future. It definitely cuts down on some of the more particular details of woodworking and sizing. This was a basic design I came up with after looking at other people's small bird pens. I'm sure this can be modified for other sizes or uses, but hopefully this will at least get your creative juices going.

This pen will be (eventually) a



Putting together the pieces.



Grinding down the edges.



*"We have been using the Dakota Gunness Uncapper, and we just love it."*

Mike Rolewicz  
Vernon, NY

.....

We sell liquid sucrose and 55% High Fructose Corn Syrup as feed for your bees.

### Dakota Gunness, Inc.

P.O. Box 106, Abercrombie, ND 58001

888.553.8393 or 701.553.8393

dakgunn@rrt.net • [www.dakotagunness.com](http://www.dakotagunness.com)

### Get your hives strong for pollination season with SuperDFM-HoneyBee.

The Original probiotic supplement for honey bees.



Look for the green "M" for best quality and value.

Created by microbiologists for your honey bees.

Made in Milwaukee, Wisconsin, U.S.A. 



P.S. Visit our booth at California State Beekeepers Association at Lake Tahoe this November 2017!



1.844.My.Micro | 248.385.3248  
[www.strongmicrobials.com](http://www.strongmicrobials.com)

WEAVER'S FAMOUS QUEENS

BUCKFAST & ALL AMERICAN

Beekeeping Supplies & Beginner's Kits

Summer 4-Frame Nuc's Pick Up Only



THE R WEAVER APIARIES, INC

16495 C.R. 319  
Navasota, TX 77868

RWEAVER.COM

936.825.2333 • RWEAVER@RWEAVER.COM

### Hardeman Apiaries

#### Italian Queens

1-9	10-24	25+
\$20.50	\$19.00	\$18.75

#### Russian Hybrid

1-9	10-24	25+
\$23.00	\$21.25	\$21.00

P.O. Box 214, Mount Vernon, GA 30445

**912.583.2710**



### TABER'S Honey Bee Genetics

Russian Carniolan, Hybrid Italian Queens & Packages



*Selected For Winter Survivorship & Mite Resistance*

**707.449.0440**

P.O. Box 1672

Vacaville, CA 95696

[www.honeybeegenetics.com](http://www.honeybeegenetics.com)



*George and Maggie getting eggs.*

three-tiered freestanding “condo” structure, but for now, we don’t quite need that much space, and also we will probably move them soon and the “standard edition condo unit” will be easier to move. Each unit is the perimeter dimensions of a hive body; roughly measuring the sides comes out to 20” wide and 16” tall. The length is approximately eight feet just to make cutting easier. We could buy 8’ pieces of wood to stabilize the outside and not have to cut any edges for that part. To cap the ends, old migratory tops were used because they fit perfectly on the sides of the hive boxes.

Here’s a basic list of materials used per “condo unit” level:

- 4 – 1”x4” boards eight feet long
- 4 – 1”x2” boards six feet long
- 1 – box of 2” wood screws
- 1 – roll of 50’ hardware wire

- 2 – packs of hinges (two per pack)
- 2 – sets of eye hooks
- 2 – handles
- 2 – wooden bound queen excluders
- 7 – deep supers
- 2 – migratory tops

The first part of construction was to take three hive boxes and space them out to be centered for an eight foot length. The 1x2 boards were cut so that they fit inside the boxes to make a nesting area. Migratory tops were screwed into the two end boxes for the sides. We wrapped wire around the outside that had ½” squares for the caging, and used a slap stapler to attach it to the boxes. The 1x4 boards were attached to the outside on the front and back for structure support and framing using way too many wood screws. On the front side, the 1x4 boards were cut to size to frame the doorways. In this instance, it’s so difficult to reach everything in a quail pen that we wanted to have a door on each side to remove eggs, clean up, and add food or water easily. The doorways were sized so that a queen excluder would cover it completely. There was some debate as to how to attach the doors. It might have been easier to attach them as a “normal” door that hinges to the left or right, but hanging hinges from the top was better for weight distribution. It took two hinges per door to hold the excluders because they are a bit heavy. We had a couple options for handles as well, going between a knob or the open handles, but knobs add too much weight to an already heavy door.

Eventually the plan is to attach legs to the bottom by way of 4x4 posts, but more hive boxes were

perfect right now because they are the same size as the boxes on the inside. We had to go for one extra though, giving us a sad odd number of boxes (I like symmetry). In the original plan to make all three interior boxes into a nesting area, I didn’t think about the fact that the waterer would not be able fit in that area. This meant that the waterer (not a light object when full) had to sit on the wire with no support. Another hive box had to be put under the waterer to keep it from pulling on the wire too much. I think it might have supported it, but I don’t want to find out the hard way that it doesn’t.

Another thing to keep in mind is that Bobby went in behind me and used a Dremmel tool to grind down the sharp ends of the screws. Sometimes the screws were just a bit too long and watching the birds impale themselves on the points was not really in the game plan. It made nice sparks and a really cool slow-motion video during the process. There’s still a few literally “loose ends” because I haven’t made time to trim the wire off of the ends, but I don’t see that as an immediate danger to the quail (maybe the turkeys since it’s at eye level).

In the future, we will attach tin to the top for a roof, but it is resting under the overhang of the shed right now and has decent overhead protection. When we have a bit more time and can build the other two levels, the tops of each one will have a tray built in to be able to remove poop without it going on top of the birds below, and only the highest level will have a roof. This will be a bit difficult to move as one entire piece, so it might stay in single “condo units” for now.

In Magic Land, the place where all my ideas are completely finished, we would have a small concrete pad with a three-sided shed that almost perfectly fit the entire quail condo and could be closed in by a fourth side during the winter to avoid drafts and keep temperature consistently while allowing ventilation. I guess after we move, maybe part of that can happen in real life! **BC**

Jessica Louque and her family are living the dream with kids, bees, birds and shoes in North Carolina.



*The finished product.*

MERRIMACK VALLEY APIARIES, INC.

# NUCS *Spring* 2018

*Taking orders starting November 1st*

*Check our website for details.* First ordered, first served.

**www.mvabees.com • 978-667-5380**

## BE BOLD OR *ITALIC* BUT NEVER REGULAR



IN YOUR HIVES.  
OFF YOUR MIND.

In order to get the longest life out of *Varroa* control products, rotation is essential. Mite resistance can develop in a short period of time and that is why it is key to rotate your control materials with products like Apistan.® Rotating on an annual or semi-annual basis with products that have different modes of action will help manage mite resistance. Start your rotation program with Apistan.®

For more information, call 1-800-347-8272 or visit [www.centralapiary.com](http://www.centralapiary.com).

Always read and follow label directions. Apistan and the Apistan design are trademarks of Wellmark International. ©2011 Wellmark International.

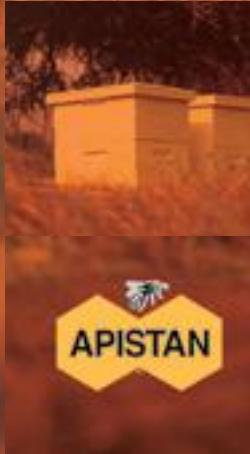

Olivarez Honey Bees/Big Island Queens is seeking motivated beekeepers to join our Hawaii team! Experience preferred. Self-motivator and ability to work in a team environment a plus. Positions are full time, salary based on experience. Great Benefits Package. Prior work history and references required. Advancement opportunities available. Submit resume to [info@ohbees.com](mailto:info@ohbees.com) or Olivarez Honey Bees Inc/Big Island Queens, P O Box 847 Orland Ca 95963, Fax: 530-865-5570, Phone 530-865-0298



 **Gold Star Honeybees**

*Setting the Gold Standard for Natural Beekeeping!*



*The Thinking Beekeeper  
Book Series*

Treatment-Free Bees • Top Bar Hive Kits  
Tools & Accessories • Classes • How-to Videos

**GoldStarHoneybees.com**

**207-449-1121**

## It's not too late!!!

As fall approaches, *mite populations can approach levels that can take down a colony well before winter.* Please make the next good weather day a **“MiteCheck Day”** and monitor for mites in your colonies.

**If they exceed 3% (3 mites/100 bees),** please choose a treatment that will work in your area and apply immediately. While you are monitoring, **please join us in this NATIONAL effort and upload your mite loads with MiteCheck at:**

[www.mitecheck.org](http://www.mitecheck.org)

## Be Included. Be Involved. Bee Informed.

Using Beekeepers' real world experiences to solve Beekeepers' real world problems



FOR MORE DETAILS, GO TO: [BEEINFORMED.ORG](http://BEEINFORMED.ORG) -OR- [BIP2.BEEINFORMED.ORG](http://BIP2.BEEINFORMED.ORG)



## Bee Smart<sup>®</sup> the Ultimate Beekeeping Products! New for 2017

D E S I G N S

### Ultimate Robbing Screen

UNIVERSAL: FITS 8 OR 10 FRAME HIVES



Catches robbing bees and immediately alerts the authorities!

**New!**



### Ultimate Capping Slicer

**New!**



AVAILABLE INDIVIDUALLY OR WITH UNCAPPER

Blades slice through caps with minimum amount of wax debris and damage to cells.

### Ultimate Bottom Board



**New!**

Slide-out Inspection Board. Reversible entrance reducers/mouseguards. More!

1-800-600-7446 • [www.beesmartdesigns.com](http://www.beesmartdesigns.com) • Made in USA

## Bee-Z-Smoker



\*Use discount code **BCMAG** excludes shipping & handling

### Cool Bee Smoke, Without the Choke!<sup>®</sup>

**What?** A long-lasting, rebuild-able power tool that produces cool smoke without fire.

**How?** Easy, safe, efficient heating element 'toasts' kiln-dried pine shavings, creating a bed of embers. Smoke is blown out the spout with a fan.

**Why?** In the end it's about the time spent with your bees – not your smoker!



**\$134.99\***

Order your beekeeping power tool for \$134.99 - use discount code BCMAG - excludes shipping and handling. Visit our website for EZ video demonstrations and proper usage techniques.

[www.BeeZSmoker.com](http://www.BeeZSmoker.com)  
603-446-7913 | [info@beezsmoker.com](mailto:info@beezsmoker.com)

After completing my WALT TOP BAR HONEY EXTRACTOR published in the October 2013 issue of Bee Culture, I wondered if my favorite five-gallon pail was large enough to use for a two frame centrifugal extractor.

I placed two 6¼ frames in the pail and decided I could space them 3" apart and still rotate them in the pail. Of course the pail is only 15" high and the frames are 19" long so the pail is too short. I could use extra pails as extensions to make my extractor tall enough to suit the frame.

Review the pictures, and then gather the following materials:

1. Two plastic pail covers
2. Four plastic five-gallon pails
3. One plastic five-gallon pail with honey gate
4. Four metal strips 1 x 13" and two 1 x 1 x 2" metal angles
5. Two wood blocks ¾ x 2" – one 3" long – one 6¾ long
6. Two 3/8" brass grommets (as used with canvas tarps)
7. Eight machine screws ½" long with nuts and eight wood screws
8. One 3/8 threaded rod 19¼ long with two nuts and 4 washers
9. Two 3/8 plain rods- one 6" long - one 1 ½" long
10. Two 3/8 coupling nuts
11. Honey strainer bag
12. Plastic cement

# THE WALT TWO-FRAME HONEY EXTRACTOR

— Walt Dahlgren

2. Cut two D shaped holes in one cover for insertion of honey frames. Drill and install grommet in the center of the cover for the shaft. This will be the top cover for your extractor. See left cover in Photo #1.
3. Cut an 8" hole in the second cover that will be attached to the bottom of the extractor. Right cover in Photo #1.
4. Cut a 1" section from the bottom of the first pail. This pail with handle is used as the top section of the extractor. Refer to Photo #2 left unit.
5. Cut a 4" section from the top of the second pail and cut the ¼" rim from the bottom. Drill five holes as shown in Photo #2 for honey drainage. Four holes are probably enough, but five gives the artistic appeal. Drill and install the grommet in the center of the pail bottom for the shaft .



Photo #1.



Photo #2.



Photo #3.

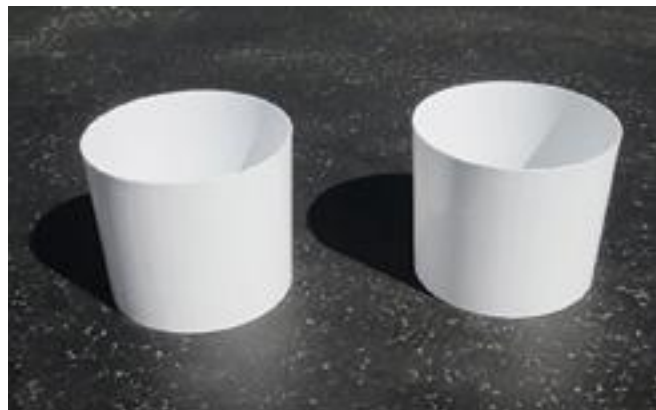

Photo 3A.

Making the extractor:

1. Cut the tabs from two covers as shown in Photos #1 & #2. Cut every other tab from each cover, then cut the remaining tabs to 1½" in length. This makes assembly and disassembly much easier.

# BETTER QUEENS BETTER WINTERS

*“What do I do now that I’m a beekeeper?”*



YOURS FOR ONLY  
**\$29.95**

## Better Beekeeping

grow your business grow and your own honey crop, raise your own queens and winter healthy bees ...

This book takes serious beekeepers past the beginning stages and learning curves and offers solutions and rewards for keeping bees a better way.

TO ORDER VISIT OUR WEBSITE  
[www.bee-culture.com](http://www.bee-culture.com)

**Bee Culture**  
The Magazine Of American Beekeeping



## Queen Right Colonies®

Beekeeping Supplies, Package Bees, Queens, Honey & More



**We are NOW accepting orders for Package Bees!**

## CALIFORNIA PACKAGE BEES

Daryll & Barry have help with your orders!!



We plan our delivery for approximately the third week in April. Check our online store & Facebook for updates.

**2018**

New World Carniolan & Italian Packages with Queen

**3 lbs. for \$TBD**

*Stop by or call to pre-order today!*

43655 State Route 162  
Spencer, OH 44275

[queenrightcolonies.com](http://queenrightcolonies.com) | 440-647-2602

*If you don't have a seat at the table,  
You're probably on the menu.*

Elizabeth Warren

HEARTLAND APICULTURAL SOCIETY

# HAS 2018

JULY 12 - 14

WASHINGTON UNIVERSITY IN ST. LOUIS  
DANFORTH CAMPUS



Photo #4.



Photo 5 & 5A.



6. Attach the cover with the hole to the above pail with screws and nuts. This is the bottom section of the extractor and will snap on to the honey storage pail. See Photo #2 and right unit in photo #3.
7. Cut a 1" section from the bottom and 4" section from the top of the two remaining pails. These are used as extensions to make the extractor high enough to suit a standard Langstroth frame. Refer to Photo #4.
8. Assemble and cement the plastic pail parts together to form the body of extractor. Place the two stack extensions in the bottom pail and fit pail with handle into extensions. See Photo #4.
9. The fifth pail with the honey gate will support the extractor and store the extracted honey.

Making the extractor shaft - Refer to Photo #6 :

1. Drill a 3/8 hole in the center of the 3" block for the top frame holders.
2. Drill a 3/8 hole in the center of the 6 3/4 block for the bottom frame holder.
3. Bend four metal strips to form the "C" shaped frame holders making inside dimensions 1 3/4 x 6 3/4 to suit a

- 6 1/4 frame. I used 1 x 13" x 16 GA stainless steel strip.
4. Attach "C" shaped frame holders to the wood blocks as shown. Use the angles to attach the lower clips.
5. Drill one end of each coupling nut to suit the plain rods. Pin the rods to the coupling nuts. The 6" rod will be used at the top of the shaft and the 1 1/2" rod at the bottom.
6. Attach wood frame holders to 3/8 threaded rod as shown with washer, nuts and coupling nuts. Use Loctite or similar product to lock the coupling nut to the 3/8 threaded shaft.
7. Make removable shaft extension. Refer to Photo #7.

Assemble shaft and cover to the extractor as shown in Photo #5. Then snap it on to the five-gallon honey storage pail into which you have placed the honey strainer bag. The honey may be bottled directly from this pail.

Use a variable speed drill to turn the shaft. When the extracting frames are empty, lift the drill off the shaft, allowing the basket to coast to a stop. Follow all normal precautions as with any extractor.

Have fun with your new WALT TWO-FRAME HONEY EXTRACTOR! Still another use for the beekeepers' favorite piece of equipment - the plastic five-gallon pail. **BC**

## Gardner's Apiaries

Spell Bee Co. LLC

510 Patterson Road • Baxley, GA 31513 • Ph: (912) 367-9352 • Fax: (912) 367-7047

### ITALIAN QUEENS

100+	\$17.00
25 -99	\$18.00
10 - 24	\$20.00
1 - 9	\$22.00

Over 100 Years of Experience • All Bees are State Inspected

**Superior S Bee**

**Improve Winter Survival**

6 Frame \$54.95      10 Frame \$64.95

2" thick wall with R8 insulation value!

Toll Free 844-260-2015  
Business 937-464-4422

The next generation of hive ware

**Dealer Inquiries Invited**



**Your Complete Bee Hive Supply Company**

All wooden-ware available assembled and painted

Hives are constructed using precision box joints.

Our hand hold cuffer leaves no tear-out!

Unassembled Frames  
Assembled Frames  
Wax Foundations  
Shallow Super & Illinois Super  
Hive Body  
6 Frame Equipment  
Deep and Medium Nuc Boxes  
Honey Processing Equipment  
Smokers, hive tools and much more.

Made with Eastern White Pine

Shipping Available

**Forest Hill WOODWORKING**  
1985 Mine Road • Paradise, PA 17562  
717-806-0193  
Manufactured in Lancaster County, PA  
www.ForestHillBeeSupply.com

**Some People Come To A Hive To Smell The Honey. Others, Just Get Stung**

**Stuttering Gets the Royal Treatment**



King George VI, whose live broadcasts of hope and inspiration kept the spirits of the British people alive during the dark days of World War II, met the challenge of stuttering with courage.

If you stutter, you should know about this gentle and courageous man, dramatized in *The King's Speech*. For more information on how you can meet your challenge, contact us.



www.StutteringHelp.org  
www.tartamudez.org

800-992-9392

**HIVE REPAIR MADE EASY**

**Do It All With FIXIT®!**

USE FOR CRACKED, CHIPPED OR ROTTED FRAMES, PATCH HOLES, RE-BUILD CORNERS, MORE!  
FIXIT® WORKS GREAT ON WOOD, METAL, FOAM, PLASTIC AND MORE!

- SAVE MONEY REPAIRING YOUR HIVES!
- 100% SAFE FOR YOUR BEES!
- PERMANENT, SELF-HARDENING - WATERPROOF
- EASY TO USE, BLEND & SMOOTH
- 2 HR. WORKING TIME
- HARD & DURABLE, GREAT ADHESION
- NO SHRINKING/CRACKING
- SAND, FILE, CARVE, & DRILL
- AVAILABLE IN 5 COLORS

**ORDER NOW:**  
**1-800-261-2837**  
ITEM SHOWN: FIXIT® 1 LB. \$20.00

**WWW.AVESSTUDIO.COM**

**AVES® MANUFACTURERS OF FINE CLAY & MACHE**  
PO Box 344 RIVER FALLS, WI 54022  
MADE IN THE U.S.A.

BEFORE

AFTER

ASK ABOUT OUR AVES SAFETY SOLVENT FOR SMOOTHING & CLEAN UP. ALSO GREAT FOR SOAP REMOVAL!

©2014 AVES® STUDIO

The Bee Shed in Rochester, MN was looking for display shelving to be used when selling honey and hive products at flea markets and other events. They decided that a bee cell would be the most eye-catching form for this display. The cell shape is instantly recognizable and immediately produces feelings of hard work and industry.

Once the hexagon shape was decided on, an additional requirement was added. The display had to be adjustable by size, that is, the number of cells used had to be variable to adjust for different space requirements.



### Parts

1.  $\frac{1}{2}$ " or  $\frac{7}{16}$ " – Plywood paneling (Cell sides)
- I used 2' x 4' handy panels.
2. 1" x 8" x ??' Pine board (Base)
3.  $\frac{1}{2}$ " Veneer edging

### Construction

In this article, we will make an individual display cell.

Since each cell is identical (a regular hexagon) they can stack together like bee cells on a frame. The size and quantity of the cells is dependent on your needs. You can either glue the sides of individual cells together for a rigid assembly or use fasteners to hold them together. Using a fastener gives you the flexibility to arrange your display to any desired size. In this

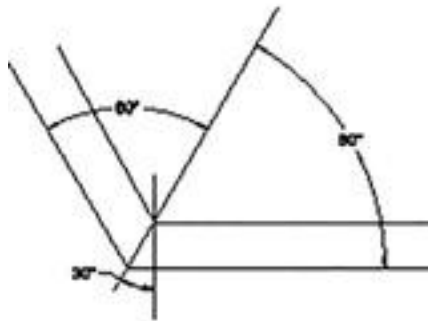

construction, each cell has six sides. That means, unlike real bee cells, there will be a double wall between common cell sides.

**Note:** Angles AB and AC are 60-degree angles. Because most saws can only make a maximum 45-degree cut, we will make 30-degree cuts. This is the 90-degree complement of 60-degrees. See step #2 for blade positioning.

**Note:** Measurements are not provided in the drawings. The measurements in the text are for reference only. You should develop all the measurements for your own situation. Although it sounds difficult, it is very easy. All the angles are 30-degrees and the outside edge of each segment is the same width. For my display, I chose 7 inches as the outside edge width. I also used 7 inches as the depth of each cell. The 7-inch depth along with a base board provided for display stability.

**Hint:** Before you start making cells for a display, I suggest you take the time to make a single cell prototype. This enables you to adjust the dimensions to your liking and it also provides a jig that can be used to hold and align the cell sides in place during assembly. Without this aligning jig, it is difficult to keep the sides in position while the glue dries.



# Build A Cell Shaped Display

Ed Simon

**Note:** I made my jig out of the standard 1" x 8" pine. The  $\frac{3}{4}$  inch thickness of the wood helped hold the sides in alignment while building the prototype.

**Note:** For overall alignment purposes of each cell, the distance to opposite corners is exactly twice the width of a side.

**Step 1:** Cut the plywood panels (part #1 above) into 7  $\frac{7}{8}$ " wide strips each 4' long.

This initial cut that will allow easier handling and cutting of the bevels in the next step.

**Note:** The 7  $\frac{7}{8}$ " wide strips are for a 7" side. The extra width will be trimmed off when the 30-degree angles are cut.

**Note:** I cut three 7  $\frac{7}{8}$ " wide strips each 4' long from each 2' x 4' panel. Each strip was then able to be cut into six 7" sides for a total of 18 sides from one 2' x 4' panel.

**Hint:** If you are using a 4' x 8' sheet of plywood, some home improvement stores will cut wood to a manageable size for you at no extra cost. I can no longer manipulate a 4' x 8' sheet of plywood, so it comes

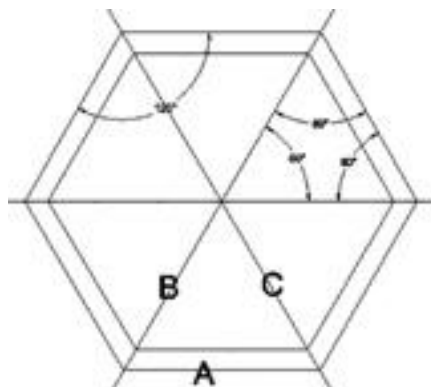

# Bee Culture's BOOKSTORE



\$25

**X12 What Do You Know?**  
By: Clarence Collison. A comprehensive study guide 8½x11, 415 pp.

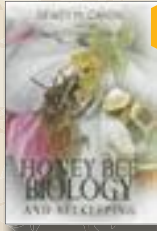

\$50

**X70 Revised Honey Bee Biology and Beekeeping.**  
The best book on honey bee biology. Dewey Caron & Lawrence Connor, 355 pp.

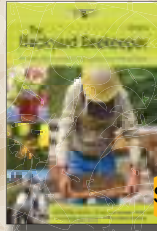

\$29.95

**X141 Backyard Beekeeper, 3rd Edition, 2014.**  
This best-selling beginner's book. Kim Flottum, 208 pp.

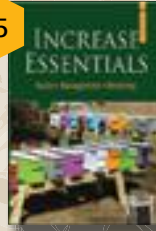

\$25

**X163 Increase Essentials, 2nd Edition.**  
Starting new, healthy & production hives. 176 pp.



\$19.99

**X167 Honey Bee Removal.**  
The only book of its kind 80 pp.



\$29.95

**X172 Better Beekeeping.**  
Growing your business. 176 pp.



\$19.95

**X216 Following the Wild Bees.**  
Beekeeping made easy. 164 pp.



\$34.95

**X178 Insect Pollination of Cultivated Crop Plants — Reprint.** Republished in its entirety. 411 pp.

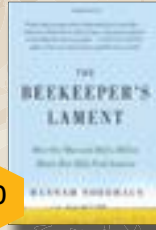

\$20

**X176 The Beekeeper's Lament.**  
The story of Miller Honey Company. 288 pp.



\$25

**X175 The Backyard Beekeeper's Honey Hand book.**  
The next level in honey marketing, production, and harvesting. 168 pp.



\$30

**X181 The Honey Connoisseur.**  
Explore how honey is made. Examine 30 common & exotic honey plants. 208 pp.



\$25

**X182 The Thinking Beekeeper.**  
Keeping Bees in Top Bar hives. 208 pp.

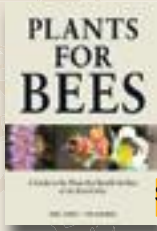

\$49.95

**X184 Plants For Bees.**  
If you want to know what bees like to eat. 311 color pp.



\$19.99

**X188 Beekeeping Journal.**  
Daily beekeeping records. 176 pp.



\$30

**X190 Wisdom for Beekeepers.**  
James E. Tew. 500 tips for keeping bees. 288 pp.



\$15.99

**X192 The Indispensable Honeybee.**  
Historical look at the beekeeping industry in 1973. 137 pp.



\$10.99

**X196 Smoking Allowed.**  
Paul Jackson's collection of antique smokers is second to none. 64 pp.



\$25

**X197 Beeswax Alchemy.**  
How to make your own candles, soap, balms, salves. 136 pp.



\$20

**X198 The Beekeeper's Problem Solver.** Jim Tew.  
The basics, equipment, biology, behavior and more. 224 pp.



\$19.99

**X203 Chicken Problem Solver.** Covers nutrition, housing, pens, pests, rearing and more. 224 pp.



\$20

**X205 Principles of Bee Improvement.**  
How to select and improve bees from the local bee population. 86 pp.



\$20

**X208 Steve Taber on Beekeeping.**  
Collection of articles from Beekeepers Quarterly. 80 pp.

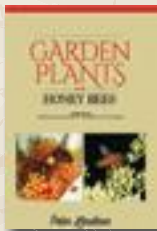

\$35

**X211 Garden Plants for Honey Bees.**  
This photo-rich guide can help you identify your most bee-friendly plants. 398 pp.



\$25

**X213 Swarm Essentials**  
The ramifications of swarming behavior, the benefits of swarming. 128pp.

**TO ORDER VISIT US AT:**  
[www.BeeCulture.com](http://www.BeeCulture.com)

All prices include domestic postage.

in handy to have the sheets cut to smaller sizes.

### Step 2 – First 30 degree Cut:

Cut a 30-degree bevel on one edge of the 4' panels. Make sure the bevel is cut in the correct orientation. See the diagram for the alignment needed.

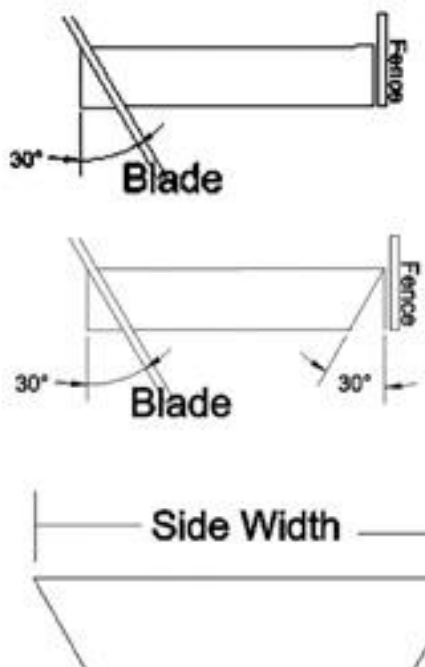

To cut the strips correctly:

- 1) Set the saw bevel angle to 30 degrees.
- 2) Set the saw blade to the correct height to cut the panel.
- 3) Set the rip guide on the saw to cut the angle.

**Note:** If only one side of the panel is good, then make sure the good side of the panel is either up or down depending on whether you want the inside or the outside of the cell to be smooth.

**Explanation:** This step will cut the bevel on one edge of the panel. The next cut will cut the bevel on the other edge at the correct width for the side of a cell.

- 4) Cut one edge of all the panels with this saw setting.
- 5) Set the saw up for the cutting the second beveled edge.

Move the rip fence to a position where the cut will make a 30-degree bevel at the correct orientation and width.

**Caution:** Measure from the tip of the blade at the panel thickness height to the rip fence. This will be the width of your cell side

6) Now make a test cut on some scrap wood to validate your settings. Change settings as needed to achieve the correct side width. Repeat step #5 until you are satisfied.

7) Cut the second edge of all the panels with this saw setting.

**Caution:** Make sure the orientation is correct for each panel. If the good side was up for the first beveled cut, then it should be up for this cut.

The result should be a trapezoid shape when looking at the end of the strip of plywood.

**Step 3:** Cut the panels into the length (cell depth) you need for your display. I made mine seven inches. You need six sides for each cell being built. If you have extra sides, hold on to them. If during assembly you find a flaw, you may have to substitute one.



**Step 4:** Sand the edges to remove any ragged/splintered wood. It is easier to do it now than to clean the edges after the cell is assembled. Leave the beveled edges un-sanded except for removing splinters. These edges will be smoothed out after the cell is assembled.

**Note:** You want the cell edges to be as sharp as possible without being dangerous.

**Step 5:** Drill two 5/32" mounting holes in each cell segment.



Space the holes 2" inches from the front and back edges and centered between the beveled edges. These holes with this spacing should allow the cells to be positioned and attached in any order or orientation.

**Hint:** Make a simple jig so the holes will be positioned correctly and align up with its counterpart in a sister cell. Using a positioning jig and drilling the holes now will ensure the holes match up in any combination of cell positioning.

**Note:** If you are going to glue the finished cells together then this step is unnecessary.

**Step 6:** Glue two of the sides together to make a wide "V".

**Jig Recommended:** This is where the jig comes in handy.

Add glue to one beveled edge on each of two sides. Then place the two sides on the outside of the jig with the glued edges touching and in alignment. Then strap the sides in place. After a couple of hours, the glue will have dried enough to very carefully remove the straps and then set the assembly aside to completely dry. Three of these assemblies are required for each completed cell.



**Note:** Use bungee cords to keep the segments aligned.

**Hint:** Place a piece of waxed paper at the glued edges, between the jig and the sides. This will prevent the glue that leaks from the joint from binding with the jig.

**Step 7:** Glue three of these assemblies made in step #6 together to make a cell. The 30-degree bevels should allow the six segments to make a complete cell (hexagon).

**Hint:** To align (square) the final assembly, the opposite corners should measure exactly twice the width of a single side.



**Step 8:** Add the veneer edging to the front of each cell. The easiest veneer to use comes with the glue already applied. This glue is activated by heat. Cut the veneer to length and shape with scissors. Then iron it to the front edge of each cell. After it cools, trim the excess width from the veneer.



**Hint:** Use a paper towel to protect the iron's surface.

**Step 9:** Sand the cell. Now is the time to make sure the corner edges of the cell are smooth. Splinters tend to release some very emotional expletives.

**Step 10:** Temporarily assemble your cells on top of the pine board (part #2), into the usual (standard) configuration you will be using. When in place drill two  $\frac{5}{32}$ "

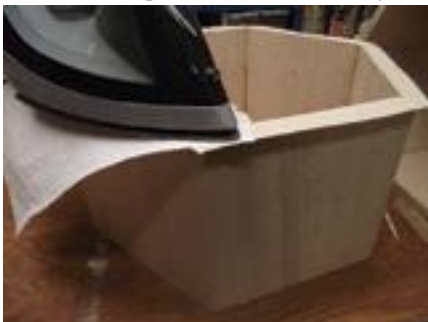

mounting holes from the bottom cells alignment holes into the base. This provides stability for the display.

**Step 11:** Stain, paint or varnish the individual cell and the base.

If you need to have flexibility in your display, you can use shortened nails as pegs to hold the cells in alignment.

**Step 12:** To make aligning pegs from nails, cut an 8d common nail to a length of  $\frac{7}{8}$ " (less than twice the thickness of a side) and then remove the rough end with a file or a grinder. These stubby nails when slipped into the holes drilled in Step #5 and Step #10, will hold the cells in position.



This step is not needed if you are going to glue the cells together.

**Note:** Using a small bolt and nut would make a sturdier display.

### Wall Display

There will probably be unused sides or sections of left over plywood. You can use these "SCRAPS" to create a neat wall display. This will look nice hanging behind your booth at the next flea market.

The steps to make a wall display are the same as the original display except for the depth. I made the depth  $2\frac{1}{2}$ " to keep the display light in weight and the shallow depth keeps the product to the front of the cell so light could reach it easier. I also glued all the cells together so they would hang nicely.

### Conclusion

An eye-catching display increases sales dramatically. Use this type of display to help you get the reward you deserve for your beekeeping skills. **BC**

Get a copy of Ed Simon's book *Bee Equipment Essentials* with detailed drawings, construction hints and how-to-use instructions for dozens of beekeeping tools and equipment from [www.wicwas.com](http://www.wicwas.com). Ed can be contacted through [SimonEdwin41@gmail.com](mailto:SimonEdwin41@gmail.com).

Established  
25 years



**The independent international magazine with the UK slant for all serious beekeepers**

FULL COLOUR throughout • 56 pages of up to date information

- Regular articles by highly respected beekeepers
- Practical hints and tips
- Latest research and environmental matters







Only \$40.00 Price includes Surface Post  
and digital edition at £15 - via Page Suite pay by paypal - approximately \$22.50

**Subscriptions:** 623 West Liberty Street, Medina, Ohio 44256, USA  
**Free Toll Number:** 800.289.7668 ext 3220  
**Please make checks payable to Bee Culture**

# GLEANNINGS

OCTOBER 2017 • ALL THE NEWS THAT FITS

## THE BETTER THE MANUKA HONEY, THE FASTER THE TREATMENT

Manuka honey can have significant healing properties, but not when low unique manuka factor (UMF) is used; Australian researchers say.

University of Sydney research tested whether UMF 20 honey had better effects on healing than UMF 5 honey and generic-store bought honey, compared to untreated wounds/

In a report published in the Australian Veterinary Journal, corresponding author, Prof. Andrew Dart from the university's School of Veterinary Science, says the research was the most recent of a series of studies investigating the effects of manuka honey on healing of open wounds of horses.

"Honey has been used to help healing of wounds since ancient Egypt," says Dart, an equine surgical specialist.

"Recent interest in manuka honey has been for its superior antibacterial activity, particularly in humans where it can be effective against many of the antibiotic resistant strains of bacteria."

Manuka honey is the only honey graded for antibacterial activity. It is graded against the standard antiseptic phenol. The grading scale is UMF with a range from 0-30.

Most honeys are active against bacteria because they contain an enzyme glucose oxidase which produces hydrogen peroxide from glucose. With heat treatment and time this enzyme is destroyed. The active constituent in manuka honey is methylglyoxal which increase in concentration over time.

The new research tested whether UMF 20 honey had better effects on healing than UMF 5 honey and generic store-bought honey compared to untreated wounds. It also analyzed whether the healing was primarily due to manuka honey's antibacterial effects or because of effects on the cells that help healing.

The study found wounds treated with UMF 20 honey daily for as

little as 12 days healed faster than wounds treated with generic honey and untreated wounds.

Wounds treated with generic honey did not heal better than untreated wounds.

Wounds treated with UMF 5 honey healed better than untreated wounds and wounds treated with generic honey but not as well as those treated with UMF 20 honey.

However, these results were not statistically different but Dart says it is possible if more animals were studied, this difference may have been significant.

Dart says his findings support previous studies that UMF 20 manuka honey does improve wound healing in horses. Most of the beneficial effects are due to the antibacterial activity but there may be some direct effects on the wound to enhance healing.

"If a wound is heavily contaminated or at risk of infection using a high UMF manuka honey is warranted, but if the wound is not heavily contaminated then using a lower and less expensive manuka honey may be beneficial," he says.

"Store-bought generic honey probably has no beneficial effect over no treatment.

"While it is not possible to directly translate this research to humans or other animals, it is likely that the effects are similar and safe based on the body of research available."

*Alan Harman*

*Bee Culture's  
Calendar Photo  
Contest: Beeyards  
At Sunset. Send  
photo w/contact  
info to  
[kim@beeculture.com](mailto:kim@beeculture.com)*

## NIGERIA PLANS LIVE BEE EXPORTS

Nigeria plans to begin exporting bees next year.

Federation of Bee keepers Association of Nigeria president Bidemi Ojeleye says the country aims to become a listed European Union bee exporting country after an EU team visit to provide training and guidelines for residue monitoring plans for bee exportation.

"For a trade in bees within the European Union, the general conditions that apply to 'other' live animals apply, as the conditions are laid down in the EU Council Directive," Ojeleye says.

The News Agency of Nigeria says to boost the country's bee production, the federal government has devised a scheme to attract young

people by subsidizing the cost of bee keeping equipment and hosting free training on bee production.

"Beekeeping generates income without destroying the habitat, while bees do not compete with any other livestock for food," Ojeleye says.

The Federal Ministry of Agriculture and Rural Development and Nigerian Export Promotion Council has produced guideline training for bee producers.

Gideon Mshelbwala, director of the Veterinary and Pest Control Services, says the training will also help show producers modern bee keeping practices so they can comply with international standards in honey production.

*Alan Harman*

## MCDONALD'S ACTS TO CUT FARM ANTIBIOTIC USE

Farmers globally have been put on notice – cut your antibiotic use or risk losing one of the biggest buyers on the planet.

Global food giant McDonald's is to reduce the routine use of antibiotics in all food animals, but stops short of eliminating all medically important antibiotics from its meat supplies.

It has announced a global policy for only sourcing broiler chickens that have been raised without antibiotics defined by the World Health Organisation as "highest priority critically important" (HPCIA) for human medicine.

The policy will be in effect in Brazil, Canada, Japan, South Korea, the United States and Europe by 2018, in Australia and Russia by 2019 and the rest of the world by 2027.

Environmental group Friends of the Earth says the company is sending a powerful signal to meat and poultry producers that they must act swiftly to reform their practices or lose potential large buyers such as McDonald's.

"We urge other fast food chains to follow McDonald's lead and get more serious about reducing the use of antibiotics in their supply chains, especially in their beef and pork supply."

McDonald's new policy updates its 2014 plan devised after it gathered a team of global experts to study and comment on antibiotic use in food animals. Their recommendations formed the chain's programme for antibiotic stewardship.

"We anticipate that the body of knowledge on antibiotic use in food animals – beef, chicken, pork, dairy cows and laying hen production – and the impact of such use on antibiotic resistance in animal and human populations will continue to evolve," it says

McDonalds says it also has to deal with the complexities of different global industry structures, government bodies and regulatory oversight, making it difficult to implement a single global approach.

"We are committed to working – to gain alignment and identify appropriate paths forward, and will

# This Year Get Your Bees Past **THE HARDEST SEASON**

## *October To April*

Saturday, Oct. 14, 2017, 9:00 AM – 4:00 PM

Bee Culture Conference Room

623 West Liberty Street, Medina, OH 44256

**Sponsored by Bee Culture Magazine**

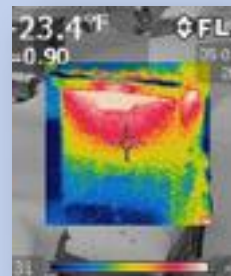

- Session 1 – Fall mite, disease management – Tracy Alarcon
- Session 2 – Winter Nutrition, evaluation, fall feeding – Kim Flottum
- Session 3 – Winter Protection – Roy Hendrickson

Lunch

- Session 4 – Emergency Winter, and Spring Feeding – Roy Hendrickson
- Session 5 – Swarm Management and Mite Control – Tracy Alarcon
- Session 6 – Spring flow, supering and making splits – Kim Flottum

**Registration \$50 includes lunch**

**Send checks to Hardest Season, 623 W. Liberty St, Medina OH 44256**

**OnLine – go to <http://store.beeulture.com/events/>**

**Call 800.289.7668 ext 3255 or 3214**

**Walk-ins welcome, but lunch not guaranteed**

### Tracy Alarcon

- 30 colonies, raises queens and Nucs
- Portage Cty Inspector 6 years
- OSBA Certified MB Manual BMP author
- NL Editor; Medina, Portage Board member



### Kim Flottum

- Bee Culture and BEEkeeping Editor
- Author 4 beekeeping books
- 40 years in the business

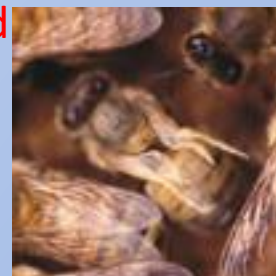

### Roy Hendrickson

- Keeping bees 43 years
- Retired 300 colony Commercial Beekeeper, + pollination, honey, nuc sales
- Writes for Both Bee Journals and OSBA NL
- Runs 30 colonies





work to develop timelines for implementation and verification criteria via 3rd party, resulting in reduction of antibiotic use in food animals," it says.

McDonald's is committed to reducing the need for antibiotics, and says it will give preference to using products from food animals supplied from progressive farming practices including the responsible use of antibiotics.

"As one of the world's largest food companies, we will seize the opportunity to use its scale for good, to influence industry change on the issue of responsible use of antibiotics," it says.

McDonald's listed seven criteria to serve as goals for its suppliers:

- Antibiotics can only be used in conjunction with a veterinary-developed animal health care programme.
- Source raw material from beef, chicken, pork, dairy cows and laying hens that are not treated with HPCIA – cephalosporins (3rd, 4th, 5th and newer generation); glycopeptides; macrolides and ketolides; polymyxins and quinolones.
- Antibiotics identified as High Priority Critically Important, Critically Important, Highly Important and Important for human medicine and now approved for veterinary use, should not be used

as first line treatment, and only be used after susceptibility testing by the attending veterinarian of the diseased animals has shown other classes of antibiotics to be ineffective.

- It will not source raw material from food animals that are treated with antibiotics used solely for growth promotion.
- Routine prevention use of antibiotics is not permitted, but suppliers may continue to use Ionophores, not used in human medicine, subject to applicable laws and regulations.
- Use animal production practices that reduce, and where possible eliminate, the need for antibiotic therapies in food animals and adopt existing best practices and/or new practices that would result in subsequent reductions of antibiotic use.
- Benchmarking and measurement of antibiotic usage is required to track performance.

McDonald's is to prioritise establishing principles and criteria for responsible use of antibiotics in food animals; develop demonstration or flagship farms for each species to demonstrate the benefits of responsible use of antibiotics; develop methods to verify their responsible use and establish goals for measuring progress.

*Alan Harman*

## MORNING COFFEE SAVED BY BEES!!

Bees will be the saviors of coffee drinkers with areas in Latin America suitable for growing coffee facing predicted declines of 73% - 88% by 2050.

Research, co-authored by David Roubik, senior scientist at the Smithsonian Tropical Research Institute, finds diversity in bee species may save the day, even if many species in cool highland regions are lost as the climate warms.

"For my money, we do a far superior job of predicting the future when we consider both plants and animals – or in this case the bees – and their biology," Roubik says. "Traditional models don't build in the ability of organisms to change. They're based on the world as we know it now, not on the way it could be as people and other organisms adapt."

The research team modeled impacts for Latin America, the largest coffee-growing region under several global-warming scenarios – considering both the plants and the bees.

The team consisted of bee experts from the Smithsonian in Panama; the International Center for Tropical Agriculture in Vietnam; the Tropical Agri. Research and Higher Education Center in Costa Rica; Conservation International and the University of Vermont in the U.S.; CIRAD in France; and CIFOR in Peru.

Despite predicted declines in total bee species, in all scenarios at least five species were left in future coffee-suitable areas; in about half of the areas, 10 bee species were left.

For land no longer suitable for coffee production, the team recommended management strategies to help farmers switch to other crops or production systems.

In areas where bee diversity is expected to decrease, but coffee can still be grown, adaptation strategies may include increasing bee habitat and maintaining native bees.

Many coffee types prefer to grow in the shade of tall trees. Choosing tree species that favor bees is a win-win strategy, the researchers say.

Roubik's favorite example of a potentially huge environmental change that did not play out as predicted is the case of Africanized honey bees, which were accidentally released in Brazil in 1957.

Roubik's studies in Panama of coffee pollination taking native rainforest bees into consideration began in the 1970s as the aggressive non-native Africanized honey bees swarmed north through Latin America.

Doomsayers predicted the worst – the killer bees would disrupt the delicate balance between tropical forest species and their native pollinators. Roubik discovered the opposite to be true.

In lowland tropical forests in Mexico, plants pollinated by very busy Africanized bees ended up producing more flowers, thus making more pollen and nectar available to native bees.

"Africanized honey bees in the Western Hemisphere both regulate their nest temperature and their own body temperature using water," Roubik says. "When the climate is hotter – unless it's too dry – they're better adapted to endure climate change and pollinate coffee, an African plant"

The research, published in the Proceedings of the National Academy of Sciences, suggests that by paying attention to biological processes and managing coffee for maximum pollination depending upon the effects of climate on both the plants and the bees, as well as strategically adjusting shade, rotating crops and conserving natural forests, it may be possible for coffee producers to adapt to climate change. – *Alan Harman*

**Z SPECIALTY FOOD, LLC**  
Moon Shine Trading Co. & Island of the Moon

<p><b>WE BUY, SELL AND PACK:</b></p> <ul style="list-style-type: none"> <li>Natural &amp; Varietal U.S. Honey</li> <li>Round Comb Honey</li> <li>Fresh Bee Pollen</li> <li>Retail • Wholesale • Bulk</li> <li>Custom Packing</li> </ul> <p>Z Specialty is a small, family run packer of honey and other tasty treats. We'd love to meet &amp; speak with you!</p> <p style="font-size: small;">Buying and Selling Honey from America's Beekeepers since 1979!</p>		<p>Contact us: tasty@zspecialtyfood.com www.zspecialtyfood.com 800-678-1226</p> <p>Visit us and send samples to our home: 1250-A Haeter Ave. Woodland, CA 95776</p>
---	--	---

*Fourth Generation Beekeeping and Queen Rearing Experience*

**Italian Queens**

Strong Hives for California Almond

Very comparative for Honey Crop and Overwintering in Northern States

April-October & January

**(530) 671-6188**  
ambees@yahoo.com

**Queen Cells**

Shipping and Local pick up

March-September

# SUBSCRIBE NOW!

BEEKeeping Magazine – Your First Three Years



Hand Delivered by  
Trusted Federal Agents

**RIGHT TO YOUR  
MAILBOX!**

**GET FOUR  
ISSUES FOR  
ONLY \$20**

(That's 30% off the Newsstand Price!)

**CALL NOW: 1.800.289.7668, ext. 3220**

**ORDER ONLINE AT:**  
[www.BEEKeeping3.com](http://www.BEEKeeping3.com)

**SEND A CHECK TO:**  
Beekeeping3  
623 W. Liberty St.  
Medina, OH 44256

We still have Spring and Summer 2017 Issues available.  
Visit: [Store.BeeCulture.com/Magazine](http://Store.BeeCulture.com/Magazine)

# CLEMSON ECLIPSE

About two miles from the Clemson University campus, where 50,000 people gathered to gaze skyward during the Aug. 21 total solar eclipse, bee researcher Jennifer Tsuruda kept her eyes focused earthward to see how honey bees behaved when nighttime darkness momentarily interrupted afternoon sun.

The lives of honey bees are intertwined with the sun. They are most active outside their hives during daylight hours when flowers tend to be unfurled and forager bees can load up on nectar and pollen. They also use the sun as a navigational reference point and can even communicate to hive mates where food is located in relation to the sun.

Tsuruda, Clemson Extension's apiculture specialist, and Olav Rueppell, professor of biology at the University of North Carolina-Greensboro, were curious how honey bee activity might change during a total solar eclipse. Prior studies from Europe have shown that bees decrease their activity outside the hive during 85- to 95-percent solar eclipses. Tsuruda and Rueppell, animal behaviorists at heart, wanted to know whether bee colonies that harbored a food surplus and few developing bees that needed feeding might differ in their response to a 100 percent solar eclipse when compared to colonies whose honeycombs were comparatively bare of food but had many developing bees.

"What's neat about this experiment is that we're looking at how flexible bees are in response to both the outside environment and the inside environment," Tsuruda said. "Meaning, inside the hive because we changed the amount of food and developing bees – also known as brood – and outside the hive because the amount of light changed."

A while back, Rueppell contacted Tsuruda about collaborating on an eclipse project. Since Tsuruda maintains several hives at Clemson University, which was directly in the path of totality, and Rueppell has an eager team of researchers who were interested in this once-in-a-lifetime opportunity, it was a great match-up. The project would not have been possible without the members of Rueppell's lab: Esmaeil Amiri, Saman Baral, Shilpi Bhatia, Anissa Kennedy, Kevin Le and Prashat Waika. Rueppell's daughter, Anika, also helped monitor hives during the eclipse.

Preliminary observations ap-

peared to indicate that honey bee activity slowed drastically during totality.

Image Credit: Pete Martin / Clemson University

"We set the hives up so that some did not have a lot of brood and they had lots of extra food," Tsuruda said. "In those hives, the foragers did not have a strong stimulus to seek food. But in the other colonies, we had lots of brood and not much food, so the foragers in these colonies had a strong stimulus to find more food to feed their developing bees."

The amount of brood in a hive, as well as their specific stages of development, influence how many



and how hard forager bees work to gather nectar and pollen via an intricate orchestration of stimuli and responses.

On Aug. 19, which coincidentally was National Honey Bee Day, Tsuruda set up the experimental hives. Her team did not want the bees to have too much time to acclimate to their newly renovated colonies; otherwise, the hives lacking food might have gone on a foraging frenzy to equalize their deficit.

Armed with counting clickers and aided by several students from Rueppell's lab, the research team gathered baseline data one day before the eclipse. Every time a bee entered or departed a hive, it was counted with a click. By determining what normal activity levels looked like at each hive, they would then be able to compare activity on a normal day to that of the eclipse day.

"We were so lucky," Tsuruda said. "The weather was similar across the days," which reduced the chance that variable weather conditions might influence their results.

Each researcher was assigned to a pair of hives to monitor: one with low food needs and one with high food needs. The researchers monitored the hives for 30-minute time blocks. On the day of the eclipse, they monitored the hives before the eclipse, during the partial eclipse leading up to totality, during totality, in the post-totally partial eclipse and after the eclipse ended. Because bee foraging activity varies throughout the day, the observations are more meaningful when specific times of day will be compared across multiple days and not just pre- and post-eclipse.

Careful to point out that the data has not yet been processed, Tsuruda was still able to provide some anecdotal observations. She noticed that

eclipse events. During a partial eclipse, ants placed some distance from their nest returned as usual. But during a full eclipse, they remained motionless in their new location and didn't march homeward until the light returned.

Tsuruda and the UNCG team removed both worker bees and drones from a hive, moved them about 500 feet, dabbed them with fluorescent marker powder and released them. A team member stood ready at the hive with two clickers and a timer. "We wanted to see if there was a difference between a worker bee and a drone in terms of their readiness or ability to return to the hive," Tsuruda said. Upon releasing them, some bees flew up and around while others stayed on the ground "because they were freaked out that they'd been put in a jar and sloshed with powder and released outside of their hive." But soon afterward, the bees started to make their way home. During the full eclipse, some bees flew up into the air but then went down to the ground and did not attempt to fly – similar to the ants – until it got light again and they began to fly home.

Precisely why bees change their foraging during an eclipse and why they stay grounded during totality after being relocated isn't known. Tsuruda said the answers to these questions could enhance our understanding about behavioral flexibility in honey bees and their ability to adapt to new and unique environments. Honey bees are the main managed pollinators in modern agriculture. They are moved in hive boxes to farmlands all across the United States, where they pollinate crops ranging from apples and almonds to cucumbers and blueberries.

"Some people don't even realize bees have brains," Tsuruda said. "But they are actually these really complex, fascinating animals."

She plans to work with Rueppell and his students to publish the findings at a future date.

But truth be told, bees are not the creatures that most fascinate Tsuruda during an eclipse.

"The animal that has the biggest change in activity in an eclipse is the human," Tsuruda joked. "We all go outside and look up. We basically shut down for the day and don't act as we normally would. How strange is that?"

*T. Delene Beeland*

# CALENDAR

## ◆INTERNATIONAL◆

**Caribbean Bee College** – November 1-4 at the University of West Indies, Cave Hill Campus, Weststand, Barbados. Two days of training and then a testing day.

For details visit <https://www.eventbrite.com/e/2017-caribbean-bee-college-tickets-34694369794>.

**Beekeeping Tour to Cuba** November 11-19 featuring visits to apiaries, processing plants, research centers and more.

Contact Transeair Travel if you are interested in more details, 202.362.6100 or [Blubic@TranseairTravel.com](mailto:Blubic@TranseairTravel.com).

## ◆ARIZONA◆

**Arizona Honey Bee Festival** will be held November 18 in Phoenix. Bee experts, kid zone, food trucks, music, demonstrations, honey tasting and more.

For information visit [azhoneybeefest.com](http://azhoneybeefest.com).

## ◆CALIFORNIA◆

**CA State Beekeepers Association** will hold their annual convention November 14-16 at Harrah's Lake Tahoe.

Featured speakers include Karen Ross, Secretary of Agriculture and Susan Talamantes Eggman, assembly member.

To register [californiastatebeekeepers.com/events](http://californiastatebeekeepers.com/events).

**UC Davis Beekeeping Classes** offered this Fall at the Davis Bee Lab.

All classes are taught by Elina Lastro Niño. Planning Ahead for Your First Hives, October 7 and Queen Rearing Basics, October 20. Class size is limited so register early. You'll need to bring your own beesuit.

For more details visit <http://eliniobeelab.ucdavis.edu/>.

## ◆CONNECTICUT◆

**CT Beekeepers Association Meeting and Workshop** with Leo Sharashkin, October 14-15 in Bethlehem.

The cost is \$25/person. Registration is required.

Visit [ctbees.org/workshop-with-dr-leo-sharashkin](http://ctbees.org/workshop-with-dr-leo-sharashkin) for details and registration.

**Back Yard Beekeepers Association 2017 speaker schedule** – October 31, Kirk Webster; November 14, Jennifer Berry.

For information visit [www.backyardbeekeepers.com](http://www.backyardbeekeepers.com).

## ◆FLORIDA◆

**FL State Beekeepers Association** will hold their conference October 28 at the United Church of Gainesville, 8:00 a.m. to 5:00 p.m.

The featured speaker is Leo Sharashkin. Also John Maynard.

For registration visit [eventbrite](http://eventbrite.com).

## ◆GEORGIA◆

**Henry County Beekeepers** will host a Beekeeping Short Course October 28 at Heritage Park, 07 Lake Dow Road, McDonough.

For information friend Henry County Beekeepers on Facebook or call 770.461.6686 or 678.983.7698.

**Georgia and Southeastern Beekeepers** will welcome Randy Oliver, October 6-7 in Griffin, GA for the Fall statewide meeting.

Other speakers include Jennifer Berry, Rusty Burlew, Keith Delaplaine, Tammy Horn and Kerry Owen.

Visit <https://gball17.wildapricot.org/event-2540629>.

## ◆INDIANA◆

**The Beekeepers of IN** will hold their Fall meeting at Fourwinds lakeside Inn and Marina, October 27-28.

Guest speaker is Roger Hoopgarner. For reservations at the Inn call 812.824.2628 and mention Beekeepers of IN for a special rate.

For more information visit [http://indianabeekeeper.com/contact\\_us/fall\\_conference](http://indianabeekeeper.com/contact_us/fall_conference).

## ◆IOWA◆

**IA Honey Producers Association** will hold their 105th Annual meeting November 10-11 at Gateway Church of the Nazaren, 140 Gateway Drive, Oskaloosa.

Keynote speakers are Marion Ellis and Dennis vanEngelsdorp.

For more information contact Eve Banden Broek, [mrstheo@iowatelecom.net](mailto:mrstheo@iowatelecom.net) or 515.491.6760.

## ◆LOUISIANA◆

**21st Annual Field Day at USDA Honey Bee Lab, Baton Rouge** will be held October 21 at the lab, 1157 Ben Hur Road. Gates open at 9:30a.m.

Pre-registration is \$30/non-refundable. There will be talks from LA Beekeepers Assn and the staff of the lab.

For information visit [labeekeepers.org](http://labeekeepers.org) or Frank Rinkevich, 225.276.3998, Sandra Hineman, 225.767.9280.

## ◆MISSISSIPPI◆

**The MS Beekeepers Association** will hold their annual meeting November 3-4 at Workforce Training Center on the campus at Southwest MS Community College.

Speakers include Jeff Harris, Jim Tew, Phil Craft, Kent Williams, David Burns, Richard Adee and more.

For information and to register visit [mshoneybee.org](http://mshoneybee.org).

## ◆NEW YORK◆

**Rochester Beekeepers** presents Peter Sieling, The Mysteries of the Beehive Explained, October 14, 1-3p.m. at Hansen Nature Center in Tinker Park, 1525 Calkins Road, Henrietta.

For information [Rochesterbeekeepers@gmail.com](mailto:Rochesterbeekeepers@gmail.com).

**Long Island 4th Annual Bee Conference** October 8, Farmingdale State College.

Pre-registration is \$65, includes breakfast and lunch. \$75 at the door. Speakers include Nicholas Nager, Jennifer Berry and Clarence Collison.

For information visit [www.longislandbeekeepers.org](http://www.longislandbeekeepers.org).

## ◆OHIO◆

**The Ohio State University Bee Lab Webinars** are held the third Wednesday of the month at 9:00 a.m. EST.

October 18: Community-based Pollinator Conservation in Cities – Kevin Matteson.

To join a webinar follow the link and log in about 8:55 a.m. – <http://go.osu.edu/theOSUbuzz>.

## ◆OKLAHOMA◆

**The OK State Beekeepers Association** will have the annual meeting October 27-28 at the Will Rogers Garden Exhibition Center, 3400 NW 36th Street, Oklahoma City.

For more information visit [www.okbees.org](http://www.okbees.org).

## ◆OREGON◆

**OR State Beekeepers** will hold their Fall Conference October 27-29 at the OR Garden in Silverton.

Speakers include Sue Cobey, Virginia Webb, George Hansen, Ramesh Sagili, Elina Nino, Judy Wu and more.

For more information visit [www.orsba.org](http://www.orsba.org).

## ◆TEXAS◆

**TX Beekeepers Association** will hold their annual convention November 9-11 at the Mayborn Convention Center in Temple.

Speakers include Jennifer Berry, Dewey Caron, Jerry Hayes and Ann Harman.

For more information visit [www.texasbeekeepers.org](http://www.texasbeekeepers.org).

## ◆WASHINGTON DC◆

**17th Annual North American Pollinator Protection Campaign International Conference** will be October 17-19 at the American Farm Bureau Federation, 600 Maryland Ave., SW, Ste 1000 W.

Speakers include Sam Droege, Jeff Pettis, Tammy Horn, Craig Regelbrugge, Deirdre Remley, Jane DeMarchi, Mary Phillips and Danielle Downey, Pete Berthelsen, Zac Browning.

Visit [kr@pollinator.org](http://kr@pollinator.org); [www.NAPPC.org](http://www.NAPPC.org).

## ◆WISCONSIN◆

**WI Honey Producers Association** will hold their Fall convention November 2-4 at Holiday Inn Eau Claire South, 4751 Owen Ayres Court. Hotel reservations 715.830.9779.

Speakers include Ross Conrad, David Tarpay, Marla Spivak.

For more information visit [www.wihoney.org/](http://www.wihoney.org/).

## Beekeeper Training DVD

~Great Stocking Stuffer~

Featuring Dr. Jim Tew & John Grafton  
2 DVD Set - Over 3 1/2 Hours in 36 Videos.

Hive Management, Queens,  
Hive Inspection, Package Bees,  
Swarm Removal, and more!

**\$24.99** Shipping included!

To order call: 567-703-6722

Or order on-line:

[www.OhioStateBeekeepers.com/dvd](http://www.OhioStateBeekeepers.com/dvd)



## THE HONEY STICK MACHINE



Easy and convenient way for small beekeepers  
to make their own honey sticks with  
their own honey.

**ONLY \$395.00**

\*how to instructions and DVD included



Buy online at [www.honeystickmachine.com](http://www.honeystickmachine.com) or call Wayne at 785.221.4756

Send check or money order to:

John & Wayne Honey Farm LLC, 3117 E 261st ST, Quenemo, KS 66528

## Display Advertisers

### Bees & Queens

A.N. Bees.....	91
Gardner's Apiaries.....	83
Hardeman Apiaries.....	77
Koehnen, C.F. & Sons.....	50
Kona Queen.....	1
Merrimack Valley Apiaries.....	79
Old Sol Apiaries.....	65
Olivarez Honey Bees Inc.....	45
Rossman Apiaries.....	59
Spell Bee Company.....	83
Strachan Apiaries.....	74
Taber's Queens.....	77
Weaver, R Apiaries.....	77
Wilbanks Apiaries.....	62

### Associations/Education

American Bee Journal.....	32
American Beekeeping Federation.....	18
American Honey Producers.....	8
Bee & Butterfly Habitat.....	57
Beekeepers Quarterly.....	88
Empire State Meeting.....	17
Farming Magazine.....	19
Hardest Season.....	90
HAS 2018.....	82
OSBA Beekeeper DVD.....	94
OTS Queen Rearing.....	65
Project Apis m.....	18
Wicwas Press.....	27

### Equipment

A&O Hummer Bee Forklift.....	4
Bee-Z-Smoker.....	80
Cowen Mfg.....	74
Dakota Gunness.....	77
Forest Hill Woodworking.....	84

Gold Star Top Bar Hives.....	79
Naked Bee Hives.....	14
Pierce Uncapping.....	72
Pierco Frames.....	6
Superior Bee.....	84
Ultimate Beekeeping Products.....	80

### Related Items

Angel Bottles.....	77
ApiCare.....	62
Apistan.....	79
Barkman Honey.....	19
Bee Hive Thermal Industries.....	67
BeeInformed.org.....	80
Beekeeping Insurance.....	7
Draper's Pollen.....	65
Fixit Hive Repair.....	84
FormicPro.....	16
Global Patties.....	2
GloryBee.....	54
Help Wanted.....	79
Hive Tracks.....	74
Honey Stick Machine.....	94
Medivet.....	37
MiteAway Quick Strips.....	31



Mother Lode Products.....	59
Nite Guard.....	69
Nozevit.....	72
OxaVap.....	74
QSI Bee Products Analysis.....	72
R. M. Farms.....	79
Root Candles.....	34
Sailor Plastics.....	19
Strong Microbials.....	77
Sugar Bricks.....	19
Thymol.....	72
Z Specialty Food.....	91

### Seeds & Plants

Ernst Seeds.....	18
Bees For Trees.....	19

### Suppliers

Acorn Beekeeping Equipment.....	3
B&B Honey Farm.....	65
Beeline Apiaries.....	50
BetterBee.....	33
Blue Sky Bee Supplies.....	Ins. Back
Brushy Mountain.....	37, Ins. Front
Dadant.....	13, 28
JZsBZs.....	65
Kelley Beekeeping Co.....	10
Mann Lake Supply.....	22, Back Cover
Maxant Industries.....	17
Meyer, A.H.....	58
Miller Bee Supply.....	42
Queen Right Colonies.....	82
Ross Rounds.....	42
Rossman Apiaries.....	59
Sherriff Beesuits.....	65
Simpson's Bee Supply.....	65
Valley Bee Supply.....	32
Western Bee Supplies.....	54

If you are having an annual meeting or teaching a beginning beekeeping class, we are happy to send you magazines to give to your attendees and students.

BUT – we need to receive your request four weeks before your event so that we have time to process your request.

Please email Amanda at [Amanda@BeeCulture.com](mailto:Amanda@BeeCulture.com) with the number of magazines needed, a complete mailing address and a contact person.

## Check Us Out At

- [www.BeeCulture.com](http://www.BeeCulture.com)
- [www.Facebook.com/Bee Culture Magazine](http://www.Facebook.com/BeeCultureMagazine)
- [Twitter.com/beeculture](https://twitter.com/beeculture)

**Sign up for the FREE News Service – CATCH THE BUZZ – at [BeeCulture.com](http://BeeCulture.com), and read hundreds of recent BUZZ posts at [BeeCulture.com/category/catch-the-buzz](http://BeeCulture.com/category/catch-the-buzz)**

**W**aiting for the gal Marilyn while she got a massage, I struck up a conversation with a gentleman waiting his turn. He said he ran a ranch dedicated to “biodynamic” principles. Biodynamic – think organic, with a pinch of mysticism. When he mentioned honey bees, the conversation took a turn.

“What do you do for mite control?” I queried.

“Nothing,” he said. He said he sees mites in his hives, “but they’re not a problem.”

“What are your Winter losses?” I asked.

“Thirty percent,” he said.

I suppose that’s possible. “But why don’t you have a mite problem, when everybody else does?” I ventured.

He attributed his bees’ vigor to his holistic earth-friendly biodynamic farming practices. At that point my BS antenna popped up.

I told him his bees don’t respect his private property rights. They undoubtedly fly to non-biodynamic neighboring properties.

He also said his bees were special in that they came from swarms, as opposed to nucs or packages. I don’t know if he called them “survivor bees,” but that’s what he implied. He described them as “very dark” and said they were so gentle he never wore a veil or used smoke.

We began to argue. Finally I said, “This is the wackiest conversation about bees I’ve ever had,” and walked off. I could have and should have used a little tact, but my famous temper got the best of me.

On the way home, Marilyn explained that she knew my new acquaintance. “Bob” is well known in his very hip community. His place is one of those idyllic farms where school kids come for field trips and where you can buy raw milk, grass-fed organic beef or a dozen eggs, if you just robbed a bank.

“Maybe Bob’s onto something,” Marilyn counseled. “Give him the benefit of the doubt. You should tell him you want to do mite tests on his bees and then see how they do. What do you have to lose? You could learn from each other. You want to educate beekeepers about mites, and he has a lot of pull in the community.”

I confessed that this was a brilliant idea.

When I wrote to Bob, first off I apologized for having gotten testy, noting that “I can be better than that.” I explained that I wanted to mite-monitor his bees with sugar-shake tests and then see how they fared over Winter. I told him that if his claims were borne out, “I’d jump for joy.” I meant it.

His reply came swiftly. It opened, “Your response to the possibility that we do not have a *Varroa* mite problem in our eight to 10 hives here (meaning that if a drone or forager does bring in a mite our bees clean/kill any intruders) was enough evidence for me that you are well entrenched in your linear industrial mindset which allows you to not only embrace but also promote chemically-laden methodology. Therefore, you are more likely than not utilizing reductionist techniques that are causing the systemic problem in the first place, hence the bloom of the *Varroa*.”

He continues: “First of all there is no way I would ever allow you to ‘monitor’ our bees – the consciousness you are suggesting to bring into our ranch, let alone deep into the organism of the beehives we host is and or would be detrimental.

“If you would like to meet and talk – in town – I would be glad to review the whole systems, ethics and principles that guide our stewardship methods and the Biodynamic approaches we implement honoring Nature’s rhythms/cosmic rhythms that guide us as to when to open a hive AND when NOT to. And share with you the abundant

health we are witnessing across the ranch in all systems.

“If you are interested in such a meeting I’d suggest you come with a far more open mind than I was witness to during our brief encounter. I sense, however, that you are quite convinced and sure of what you think you know. So such a meeting would likely fall on deaf ears.”

A little later: “I understand that I must also educate . . . so for the bees’ sake and the possibility of turning someone from the dark side, I will consider burning a few of the precious hours I have left on this plane to meet with you in some neutral place. If so what we will review will be an entirely different paradigm, one you cannot so easily take apart . . .

In closing, we cannot eradicate Nature. There always have been *Varroa* mites and there always will be AND they are not the enemy. They are the messengers. When you kill them you encourage them to come back a hundredfold because they then need to make their message to you even stronger/louder. They are not the problem . . . The problem is how people are working the bees, that and the pervasive use of pesticides, herbicides, and fungicides across the land.”

His remarkable finale: “Ed, people are the problem. Maybe what we need then is a “humacide.”

Look, I just wanted to do a little test, thinking that Bob might have some bees that either did not tolerate mites or maybe somehow learned to live with them. Or maybe just call his bluff. I wasn’t prepared to receive a lecture from someone who apparently didn’t even understand that *Varroa* are a recent phenomenon in honey bees. The “humacide” remark struck me as bizarre, too. Didn’t Hitler and Stalin try this? He had to be kidding.

Maybe Bob made a point or two worth considering, but I respectfully declined his invitation to meet. I was very polite. See, I *can* do better.

**Ed Colby**

## A Tale From The Dark Side

**BOTTOM BOARD**

# Blue Sky

bee supply®



**HALF SIZE  
CUT COMB BOXES**  
160 ct box  
**\$119.95**

#CCH-160 REG. ~~\$129.95~~

ALSO AVAILABLE IN  
80 CT BOX FOR \$72.00

**MEGABEE  
POLLEN PATTIES**

10 lb box  
**\$29.95**

40 lb box  
**\$76.95**



MegaBee Patty



**MEGABEE  
DRY POLLEN**

5 lb bag  
**\$26.45**

## Lega Equipment

**LEGA 15 FRAME W/ MOTOR**

**\$948.00**

#LG515MEX REG. ~~\$998.95~~

This Italian made extractor is perfectly balanced. Extracts 15 6-1/4" or 5-3/8" frames or 5 9-1/8" frames tangentially. Built with the highest quality German made 110 volt motor available. Two year warranty included.



**RESPIRATOR  
& GLOVES  
REQUIRED WHEN  
USING THIS UNIT.**

**LEGA HOT AIR OXALIC ACID  
VAPORIZER COMBO**

**\$398.00 + FREE SHIPPING**

WHEN YOU PURCHASE THE COMBO

#HAOV-SHG REG. ~~\$447.95~~ This device is used with a hot air gun (Steinel HL 2010 E IntelliTemp is recommended) to vaporize Oxalic Acid. It is the fastest way to apply OA to a larger number of hives. 15 sec. per hive!



## Honey Bottling



### PLASTIC PANEL BEARS

2 oz Panel Bears \$229.95/800 ct. Case No Caps  
6 oz Panel Bears \$181.45/660 ct. Case No Caps  
8 oz Panel Bears \$139.95/525 ct. Case No Caps  
12 oz Panel Bears \$109.95/400 ct. Case No Caps  
16 oz Panel Bears \$94.69/240 ct. Case No Caps  
24 oz Panel Bears \$85.50/195 ct. Case No Caps



### GLASS MUTH JARS

4 oz - \$28.49/36 ct. Case  
8 oz - \$12.95/12 ct. Case  
16 oz - \$16.95/12 ct. Case  
includes corks

### CLASSIC PLASTICS

8 oz - \$19.99/50 ct. Case  
16 oz - \$23.99/50 ct. Case  
32 oz - \$39.99/50 ct. Case  
No Caps



Family Owned & Operated in Ravenna, Ohio 44266  
(877) 529-9BEE | [www.blueskybeesupply.com](http://www.blueskybeesupply.com)

# Pro Health



## A Feeding Stimulant with Essential Oils

- Promotes digestive health
- Aids in overall health of bees
- Helps prevent syrup fermentation
- Stimulates bees
- Promotes healthy, vigorous hives
- Natural calming effect when sprayed on bees

Contains no  
Sodium Lauryl  
Sulfate



FD-350	<b>Pro Health</b> pint.....	\$ 21.95
	(Makes up to 25 gallons)	
FD-351	<b>Pro Health</b> gallon.....	\$ 99.95
	(Makes up to 200 gallons/757.08 l)	
FD-352	<b>Pro Health</b> 5 gallon.....	\$ 469.95
	(Makes up to 1000 gallons)	
FD-353	<b>Pro Health</b> 55 gallon.....	\$3995.00
	(Makes up to 11,000 gallons)	

**MANN LAKE**  
WE KNOW BEES

**800-880-7694**

[www.mannlakeltd.com](http://www.mannlakeltd.com)

\*Free shipping applies to most orders over \$100 sent standard service within the lower 48 states.  
Prices are subject to change without notice.