



REFERENCE GUIDE FOR EOD AND SAPPERS

“Engineering Munitions Used in Ukraine

Compiled by: “Minley”

Moscow
2025

Table of Contents

Introduction	2
High-Explosive Anti-Personnel Mines	
1. Belgian Anti-Personnel Mines.....	- M409 high-explosive mine 5
2. Brazilian anti-personnel mines.....	- T-AB-1 high-explosive mine 6
3. Ukraine's PPM	- “PRYANIK” high-explosive mine.....7
4. Ukrainian Military Equipment.....	- “EKLER” high-explosive mine10
5. Ukrainian PPM	- “MYLNITSA” high-explosive mine.....12
6. Ukrainian Military Police.....	- “FLYAGA” high-explosive mine.....13
7. Ukrainian Military Equipment.....	- “PAKET” high-explosive mine 14
8. Ukrainian Military Equipment.....	- “MUHA” high-explosive mine 15
9. Ukrainian PPM	- “LIGUMINA” high-explosive mine.....16
10. Ukrainian Military Equipment.....	- “UKRLEPESTOK” High-Explosive Mine 17
11. Ukrainian Military Equipment.....	- PPM-1P high-explosive mine18
12. Ukrainian PPM	- “BOLT” High-Explosive Mine.....19
13. PPM of Ukraine	- “Penal” high-explosive mine.....20
14. Ukrainian Army	- HFM0050 high-explosive cumulative drop mine.....21
15. Ukraine-U.S. Joint Project.....	- “STIK-F” (Stick IB) engineering munition 23
16. U.S. Military high-explosive mine.....	24
17. Italian high-explosive mine.....	26
18. Italian high-explosive mine.....	28
19. Italian high-explosive mine.....	30
20. French DV 59 high-explosive mine.....	32
21. Yugoslav high-explosive mine.....	34
Directional fragmentation anti-personnel mines	
22. U.S. Anti-Personnel Mines.....	- M18A1 "Claymore" fragmentation mine37
23. Yugoslavian anti-personnel mines.....	- MRUD fragmentation mine39
24. Finnish anti-personnel mine.....	- MPIM “HAILSTORM” fragmentation grenade41
25. Finland's PPM	- “MINI HAILSTORM” Fragmentation MPIM.....42
Fragmentation anti-personnel mines with circular blast effect	
26. German anti-personnel mines.....	- DM-41 fragmentation mine44
27. U.S. anti-personnel mines- M16A1 fragmentation mine.....	45
28. M-58 (M-72) fragmentation grenade.....	47
29. M-86 fragmentation grenade.....	49
30. POM-5 (K-2) fragmentation grenade.....	50
31. Fragmentation PPMs	- M-0.5 “Kukuruza”.....55
32. Ukrainian Anti-Personnel Mines.....	- UPM-O fragmentation mine56
33. Ukrainian Anti-Personnel Mines.....	- “Volchek” explosive device57
Fragmentation anti-personnel submunitions	
34. U.S. ammunition	- M-42 submunition.....59 -
35. U.S. ammunition	M-74 submunition.....61 -
36. U.S. ammunition	M-77 submunition.....63 -
37. U.S. ammunition	M-85, M-87 submunitions.....65
Anti-tank anti-track mines	
38. U.S. anti-tank mines - M-6A2 anti-track mine.....	68
39. U.S. anti-tank mines - M-15 anti-track mine.....	70
40. U.S. anti-tank mine - M-19 Anti-Track Mine.....	74
41. U.S. anti-tank mine - M-21 anti-track mine.....	76
42. British anti-tank mine - L9A2 and L18A1 anti-track mines.....	78
43. Belgian anti-tank mines- Panzermine M/56 anti-track mine.....	80
44. Anti-tank mines, Denmark.....	- Panzermine M/47 anti-track mine82
45. Swedish Anti-Tank Mines.....	- Stridsvagnsmina m/52B anti-tank mine83
46. Yugoslavian anti-tank mines.....	- TMA-4 anti-track mine88
47. Romanian anti-tank mines.....	- MAT-62B anti-track mine90
48. Romanian anti-tank mines.....	- MAT-76 anti-track mine91

49.	Bulgarian anti-tank mines.....	- RT Mi-BaIII anti-track mine	93	
50.	Bulgarian anti-tank mines.....	- ATM-01 Anti-Vehicle Mine	94	
51.	German anti-tank mines.....	- DM 11 anti-track mine	96	
52.	German anti-tank mine- DM 21 anti-track mine.....		99	
53.	Ukrainian anti-tank mine.....	- TM-2025 anti-track mine		10
54.	Anti-tank mines of Ukraine.....	- TM-124 Anti-Track Mine		2
55.	Anti-tank mines of Albania.....	- MKTVT anti-track mine		10
56.	China's anti-tank mines- Type 81 anti-track mine.....		107	4
57.	Italian anti-tank mine	- MATS-1.4 Anti-Vehicle Mine.....	109	10
58.	Spanish anti-tank mine- S-3V anti-vehicle mine.....		110	6
<i>Anti-tank bottom-contact mines</i>				
59.	ATMGermany	- DM31 anti-bottom mine.....	114	
60.	Anti-Germany tank mine	- DM1274 (DM1274A1) anti-tank mine.....	117	
		- P ro DM1399 (AT-2) anti-submarine mine.....	121	
61.	Anti-Germany tank mine	- HPD F2 anti-bottom mine.....	123	-
62.	Anti-France tank mine	UMK anti- -barrel mine.....	126	
63.	Anti-Poland tank mine	- Against , the MN-123 anti- -mine.....	127	
		- MR-123 anti-tank mine.....	129	
		- -type anti-submarine mine MS-71.....	130	
64.	PTMPoland			
65.	PTMPoland	- BLU-91/B anti-submarine mine.....	131	
66.	ATGRomania M	- M70 and M73 anti-tank mines.....	132	
67.	ATGUnited States M	- M78 anti-tank submunition.....	135	
68.	ATGUSA M			
69.	APMUSA			
<i>Anti-tank anti-</i>				
70.	German anti-tank mines- “PARM DM12/22” anti-side mine.....		137	
71.	German anti-tank mines- “PARM NextGen” anti-ship mine.....		139	
72.	French anti-ship mine	- F1 Anti-Ship Mine (MI AC AH F1).....	141	
73.	French anti-ship mines- F2 Anti-Ship Mine (MI AC AH F2).....		144	
74.	Estonian anti-ship mines.....	- Anti-ship mine RK-14/FORDONS MINA-14		146
<i>Universal anti-tank mines</i>				
75.	Yugoslav Anti-Tank Mines.....	- TMRP-6 multipurpose mine		149
76.	Czech anti-tank mines- Mi-U multipurpose mine.....		152	
<i>Special Mines</i>				
77.	United States	- SLAM M2 and M4 multi-purpose munitions.....	156	
78.	USA	- M 49A1 signal mine.....	159	
79.	US	- M142 fuse.....	161	
80.	Czechoslovakia	- RO-4 booby trap.....	163	
81.	Yugoslavia	- SU-24-M.83 delayed-action fuse.....	164	
82.	Yugoslavia	- MPR-M85 anti-vehicle magnetic mine.....	165	
83.	Ukraine	- “Kirpich” anti-personnel trap mine.....	166	
84.	Ukraine	- “BEP-LD-M1” non-contact electronic fuse.....	167	
85.	Ukraine-USSR	- Standardized smoke grenade UDSH-U.....	168	

NOTE: Based on information from the open press;

MINLEY

In Nenets mythology, Minley is one of the most powerful figures, a giant bird



with seven pairs of iron wings.

It creates the wind at the command of the god Numa. It is believed that thunder is the flapping of Minley's wings, and lightning is the flash of its eyes. It is considered the son of the supreme god Numa.

Her image is deeply symbolic and multifaceted: she serves as the embodiment of the elements, a dangerous abductor of humans, and an assistant to shamans. She controls

the winds and inclement weather. If Minley is in a good mood, she bestows happiness upon people, but if she is displeased, she can bring misfortune.

Introduction

Mines—some people don't even consider them weapons—yet they were the main companion of all wars in the 20th century, and clearly in the 21st as well. Only at first glance does the idea of packages of explosives buried in the ground, waiting for unlucky infantrymen or tank crews, seem outdated and laughable. Experience from global conflicts shows that anti-personnel and anti-tank mines will continue to be found in liberated territories for a long time to come (for more than a decade).

During the special military operation, thanks to the efforts of the Ukrainian Armed Forces and foreign mercenaries, Ukraine has turned into a vast minefield—about 40 percent of the country's territory has been mined. For eight years, foreign military instructors trained Ukrainian soldiers in demolition work and taught them to lay not only Soviet-made mines but also those from NATO countries.

Ukrainian Armed Forces units are equipped with NATO weapons (from Germany, France, and other European countries), but most of the mines are from the United States. Very often, our sappers encounter German anti-tank and anti-personnel mines, which the enemy fires at our positions using remote-mining systems (artillery, MARS-II-type multiple rocket launchers, cluster bombs, and hexacopters).

It is now clear that the actions of the engineering units (and all personnel attached to them) played a decisive role in halting the Ukrainian offensive in the south.

The tasks of laying and neutralizing anti-personnel and anti-tank mines (including foreign ones) can only be accomplished with a solid understanding of the physical characteristics of engineering munitions and the rules for handling them.

Old Soviet TM-series mines remain the enemy sappers' primary anti-tank weapon. However, anti-tank and anti-vehicle mines from foreign countries are being used with increasing frequency. The appearance of NATO-standard mines has not gone unnoticed. Despite their considerable age, such weapons pose a certain danger to our armored vehicles and, accordingly, can affect their combat effectiveness. Mostly, of course, they are laid haphazardly (due to a rapid retreat), but quite often they plant anti-tank mines at greater depths so that the vehicles are not destroyed immediately, but only after some time, once the vehicles have rolled out a track. Furthermore, such mines are quite difficult to detect with probes and mine detectors. There are cases where anti-tank mines are laid alongside anti-personnel mines. When an "Frog" mine detonates, the anti-tank mine explodes along with it.

Another favorite tactic of the enemy is to mine corpses, as well as disabled vehicles—tanks or infantry fighting vehicles, ammunition boxes... To increase the lethal effect, Ukrainian soldiers tie several "Lemon" mines together with electrical tape and connect them to a single detonator.

The militants of the Armed Forces of Ukraine do not shy away from making booby traps. Explosive devices are placed inside cans of condensed milk, stewed meat, or... boxes of candy. An explosion occurs when the "surprise" is opened.

Thus, various types of mines—both Soviet and foreign models, factory-made and homemade—are widely used in the current conflict. Using a variety of explosive devices, Ukrainian forces are attempting to slow down the advance of our troops. In addition to standard mining operations using mine layers, artillery, and the like, "Baba Yaga"-type drones are being deployed to carry heavy anti-tank mines—both for laying minefields and as concentrated charges to destroy our soldiers' shelters.

But no matter how the enemy tries to hold back our advance—we are still moving forward with confidence!

Because our cause is just! The enemy will be defeated, and victory will be ours!!!

M409 Anti-Personnel Mine (Belgium)

The Belgian PRB M409 anti-personnel mine, or simply the M409, was manufactured not only in Belgium but also in **Portugal under the designations M411 and M969.**



A round anti-personnel mine with a plastic casing (AP), a miniature metal mine of minimal size designed to injure or kill through the blast effect; the upper part of the mine consists of a solid plastic frame and a surface-pressure membrane. The mine is made entirely of plastic, with the exception of the spring-loaded metal firing pins and the dual-detonator housing. Therefore, it is difficult to detect.

Main Specifications:

Mine weight: total.....183 g
 Explosive (hexogen mixture)....80 g
 Dimensions: diameter.....8.2 cm
 height.....2.8 cm
 Actuation force..... . 8–23 kg



The mine consists of a lower casing containing an explosive charge and a double detonator. A plug is glued behind the detonator, which securely holds the double detonator in place within the mine casing. The mine casing is sealed with a plastic cap. A pressure plate is glued to the top of this cap. In the center of this plate is a pressure trigger that must be stepped on. A striker release lever (black) is glued to the underside of the pressure plate. The mine has a double impact fuse. **The firing mechanism consists** of two hook-shaped needles that are spring-loaded. As soon as the side release lever is pressed down far enough, the two needles swing inward, piercing the detonator's primer (red hole). This causes the primer, the detonator, and the mine to explode. During transport, the protective cap is held in place by a wire clip, which prevents the pressure plate from lowering.

The lower part of the mine's casing has small stiffening ribs running from top to bottom around its circumference.

There is no delay mechanism; the safety feature is a plastic cap held in place by a pin, which prevents the detonator from being pressed.

The transport/safety cover has a raised radial design with six stiffening ribs and an opening that fits over a bolt at the top of the anti-personnel mine's body.

The transport/safety cover is secured by a metal safety pin, which prevents the antipersonnel mine from detonating during normal handling.

The mine is armed by rotating the safety cap. After rotating it one full turn, the mine is armed. After the mine is deployed, the safety cap and the pin holding it in place are removed.

This is a pressure-activated mine; it is very small, but contains enough high-explosive to sever the foot of anyone who steps on it.

Its only metal components are two steel firing pins and two aluminum caps on the fuse. Their total weight does not exceed 1 gram, which makes detecting this mine using electromagnetic means an extremely difficult task.

A solid-color plastic casing. It is usually dark green or sand-colored.
 The safety cap may be black, transparent, or the same color as the mine's casing.

The mine was discovered by colleagues in the area where the special military operation is taking place.

T-AB-1 Anti-Personnel Mine or MAP NM T-AB-1 (Brazil)

The T-AB-1 anti-personnel mine, or MAP NM T-AB-1, is a small



cylindrical, fully waterproof, and impact-resistant Brazilian anti-personnel mine.

This anti-personnel mine contains a minimal amount of metal, found only in the steel firing pin (0.36 g) and the aluminum detonator (0.15 g).

Main Technical Specifications

Mine weight: total.....	125 g.
Explosive.....	62 g
Dimensions: diameter.....	6 cm
height.....	6.1 cm

The mine contains a 62-gram charge of pentolite (a 50/50% mixture of pentrite (TEN) and TNT) and an intermediate detonator.

The pressure fuse has a pressure threshold of 20 kg, and the primer contains a pyrotechnic mixture that is ignited by the impact of the firing pin.

The mine is typically olive-green in color and uses the AC Min NM AE T-AB-1 high-pressure fuse. It is no longer in production—production ceased in 1989—and all operational stockpiles have been destroyed.

Brazil's ratification of the 1999 Ottawa Treaty banning the production, stockpiling, accumulation, and use anti-personnel mines may have contributed to the fact that this T-AB-1 anti-personnel mine is actively used as an anti-tank fuse.



General Design of the Anti-Personnel Mine

This mine is present in Ecuador and Libya. In Libya, mines of this type were widely used in 2011 by various parties, and they were used to mine the perimeters of Libyan National Army bases.

In November 2024, reports emerged that this mine had appeared in the Ukrainian Armed Forces.

The two halves of the “Pryanik” mine’s “shell.” The cap with a self-tapping screw. The lower part containing the explosive and the tube for the detonator. The detonator is inserted into the tube. The two halves are screwed together.

Diagram of the “PRYANIK” mine.



“Pryanik” mines can be scattered by hand, which, in theory, could be carried out by enemy sabotage groups in our rear areas. However, in practice, they are most often deployed remotely using a quadcopter. A makeshift cluster system is attached to the drone. It consists of sections of



of PVC pipe of a suitable diameter, with 3–5 mines placed in each. The design features lids that open on command from the drone operator’s remote control, releasing the mines to scatter them across the target area.

A makeshift cassette system for dropping “PRYANIK” mines from a drone. Visible are perforated tubes—blue in color—and lids, as well as some sort of rubber band involved in the system for holding the lids in place and then opening and releasing them.

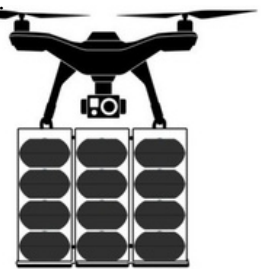

These devices are lightweight; when dropped from relatively low heights, the mines remain intact and ready for use.

Thanks to their shape, “Pryanik” mines land on one of two flat surfaces—it doesn’t matter which one. If stepped on, the thin, brittle plastic breaks easily, and the tip of the self-tapping screw pierces the primer. This ignites the main explosive charge.

The widespread use of “Pryanik” mines is held back by the enemy’s lack of a serious production program. For now, these are amateur “make-shift” creations. The scale is modest, and the capabilities of 3D printing are limited. Production capacity is modest, and are already tied up with various other tasks.

So, of course, the mine is dangerous and unpleasant. It poses a threat to soldiers in current operations, and many years later, some tourist, mushroom hunter, or fisherman might fail to notice such a “mushroom” in the forest floor, leading to a tragic outcome. At the very least, they’ll suffer a serious foot injury—and that’s assuming they can administer first aid to themselves and make it out of the forest... So, in regions that have been affected by military activity, you need to be especially vigilant about various strange objects under your feet.



The mine has gone into mass production. It has already been modified—a plate has been added that serves as a wing for gliding and a “soft” landing on the ground (like the PFM-1), and some

mines, a safety strip—a strip of plastic (cardboard can also be used)—has been added.



In the fall of 2024, it appeared in the Kursk and Belgorod regions, and in the fall of 2025, our troops discovered an even newer version of this mine in the Zaporizhzhia sector

The new version of the mine features an electric detonator. A “pill-type” battery is used as the power source.



In addition, the enemy increased the explosive charge to 45 grams and added fragmentation elements in the form of scraps of wire and bolts. Consequently, the mine’s weight has increased to 130 grams.

The mine’s safety mechanism remains the same—a strip of dielectric material.

In addition, as an extra



safety measure, the power cell contacts are routed to the mine’s outer surface and insulated; these are short-circuited by the sapper immediately before deployment (installation).

This, in turn, serves as a telltale sign (depending on the length of the wire tails) for an observant sapper!



In the fall of 2025, another upgrade to the homemade “Pryanik” mine appeared on the LBS.



The upgrade consists of an increased amount of explosive material in the mine, as well as the replacement of the power source with a more commonly available battery (a supply issue).

“Eclair” Anti-Personnel Mine (Ukraine)

The enemy has begun using new anti-personnel mines. On the Sumy and Zaporizhzhia



fronts, the Ukrainian Armed Forces have begun lacing our offensive lines with these inconspicuous-looking mines—deadly “garage-made” creations, semi-artisanal mines whose casings are 3D-printed.

Visually, they resemble a lighter (similar to the Soviet PTM-3 antitank mine, only smaller in size: about 10–11 cm long, 3.5–4 cm wide and tall), but they detonate upon contact.

The device is oblong in shape—blocky with rounded edges. Among familiar objects, (purely in terms of geometry), it resembles a woman’s lipstick or a pair of eyeglass cases. However, it is clearly larger than a lipstick and smaller than a pair of eyeglasses.



Because of its elongated, block-like shape with smoothed edges,



it has been nicknamed “soap dish” or “éclair” among soldiers.

They come in brown or green. All are matte. That is, they blend in very well with the ground, in forest litter, in grass, and in dirty snow.

The casing, 3D-printed from plastic, consists of two parts: the main “cylinder” containing the explosive (30–35 g PVV-7) and a cap.



The cap is geometrically more complex cap, and that’s where the main functionality is located. On the side is something like a wing, similar to the geometry of the PFM-1 mines, which allows the mine to spin in the air after release and glide more smoothly. This means it lands more gently on the surface.

There is a central bushing supported by two thin plates (fragments of the cap’s body). This provides a spring-like force and allows the sleeve to move when pressed.

Sleeve movement when pressed ⇒



A slot is provided for the safety plate, which also serves as a pressure-activated target sensor.



Left: view from the “cup” side; the end face of the sleeve is visible, into which the striker with a spring is inserted and the MD-5M detonator is then screwed in.

Center: side view of the cap. Visible are the firing pin with “tab” for the safety pin protruding from the top, and the safety plate, against which the firing pin also rests when cocked.

Right: top view of the cap. The firing pin is protruding

The explosion is initiated by a common MD-5M detonator (*or its semi-artisanal clones*). The detonator’s primer is activated by striking.

The firing pin is very simple, with a spring-loaded stop. At the rear end of the firing pin, there is a transverse hole (eyelet) into which the safety pin is inserted.

Components: Safety plate, firing pin, spring



Plastid is packed into the lower part of the casing (“cup”). The firing pin with the spring is inserted into the sleeve of the cap. Pressure is applied using a tool that fits the diameter (*a spoke, a thin screwdriver, a wrench*), driving the firing pin into the sleeve. The spring compresses, and the end of the striker with the tab protrudes outward from the cap. Insert a pin (*a pin, a piece of wire*) into the tab, securing the striker in the cocked position. Pull the striker back slightly by the pin. Insert



safety plate into the slot. Its edge also rests against the striker. Release the striker; the plate is pressed against it by the spring and holds firmly in place.

Left: a disassembled mine; the pin holds the striker in place.
Center: the bottom of the “cup” where the explosive charge is packed.
Right: Cap with an MD-5M detonator

The MD-5M fuse is screwed into the sleeve. The active part of the detonator is immersed in plastic explosive, and the two halves of the mine casing are pushed together, assembling the mine into a finished product.



As a result, after final assembly, the mine weighs approximately 80–100 grams. However, since the mine is currently manufactured by hand (not industrially), the weight may vary.

Like all mines, the enemy tries to camouflage them using whatever materials and means are at hand. Primarily rags, clay mixed with straw, and grass held together with glue. All of this is designed to take advantage of the troops’ inattention.



This is how the glue is applied and camouflage



The enemy’s sappers continue to improve their devices. This time, they’re incorporating traps into them. This doesn’t mean that every mine contains a trap. But since the mines are scattered from a container, there will be several of them within the detection area at once, while only 1–2 per container will contain a trap. Therefore, upon detection, you shouldn’t dismantle them (unnecessarily). It can be triggered either when disassembled or when moved from its original position (depending on the mechanism).



“Mylnitsa” Anti-Personnel Mine (Ukraine)

In the summer of 2025, yet another wave of improvised devices began appearing along the front lines. As evidence, the enemy has fewer and fewer standard, industrially manufactured mines.

Consequently, they are beginning to “invent” their own homemade devices. This time, they didn’t waste much time and based their “idea” on an old Soviet mine, the PMD-6.

The mine’s casing, like that of all homemade devices, is printed on 3D printers. After assembly, the two halves of the casing are secured with a soldering iron



in several places on both sides and is additionally wrapped with ordinary duct tape (for reliability when dropped from a drone).

The explosive used is a plastic explosive, such as C-4. The fuse (an analog of the MUV-type fuse) is also printed on a 3D printer.

The mine is dropped from a drone. Since the mine is lightweight, it appears that mines of this type are dropped from a container (like PFM mines) in batches of dozens at a time.

The mine’s operating principle is similar to that of the PMD-6 mine, except that here the casing itself breaks open and a T-shaped fuse is triggered.

Mines of this type must be camouflaged using any available materials, such as clay, straw, and bark held together with glue...



More detailed information (technical specifications) is not yet available.

“FLYAGA” Anti-Personnel Mine (Ukraine)

In 2025, another product of Ukrainian craftsmen’s ingenuity appeared.



It is an anti-personnel high-explosive mine, which they named “FLYAGA” or “FUNFYRIK.”

The mine is used as a payload dropped from UAVs. It is manufactured using a 3D printer. Essentially, it is analogous to the PFM and PMN mines.

A metal element is used as a fuse (as in the PMN mine)—the cut-off time in around 30 minutes.

The safety pin is removed before takeoff.



The mine is armed upon impact with the ground.

The mine’s operating principle is similar to that of the PMN mine, with the difference that the mine’s casing is made of soft 3-D plastic. An MD-9 (or equivalent) is used as the fuze.



The explosive used is a plastic explosive such as “Plastit” or C-4.



In a single flight, a quadcopter can drop up to 20 of these mines at once. Therefore, if one is detected, you must be prepared to encounter the rest of the dropped mines.

More precise specifications of the mine are not yet known. Our sappers have not yet recovered any specimens of these mines.



“Paket” Anti-Personnel Mine (Ukraine)

In 2025, Ukrainian DIY enthusiasts are intensively mastering the production of their own rapidly produced anti-personnel mines in an attempt to at least try to hold back the advance of our troops. Supplies of Western models are gradually running out (old stock was sent to Ukraine from warehouses long ago, and new, fresh supplies will come in handy for themselves...). Therefore, the Ukrainian Armed Forces have no choice but to switch to homemade devices.



And so another marvel of 3D printing was brought to light by the enemy: a remote-activated pressure-activated high-explosive anti-personnel mine

via a drone—though it now appears to incorporate a circuit breaker, an electric detonator (there are also variants using a detonator cap and an electric igniter), and a power source.



The casing is made of two “soft” plates held together with electrical tape. Essentially, this is yet another variant of the “petal mine.” Upon hitting the ground, the mine will automatically arm itself. It has no safety mechanisms or self-destruct

. Judging by its weight (exact data are not yet available), the mines are dropped from small containers carried by quadcopters. Therefore, upon



a single mine is detected, one must be prepared to encounter the rest of its “brothers” from the same container. Technical specifications are not yet available.

Recently, the enemy has also begun to camouflage them using covers made of camouflage fabric, plastic bags, and the like.



Enemy sappers continue to refine their devices. This time, they are incorporating traps into them. This does not mean that every mine contains a trap. However, since the mines are dropped from a container, there will be several of them within the detection area at once, while only 1–2 per container will have a trap. Therefore, upon detection, do not disassemble them (unless necessary). It can be triggered both when disassembling it

or when moved from their original position (depending on the filling).

“Mukha” Anti-Personnel Mine (Ukraine)

Another makeshift pressure-activated mine from the enemy, codenamed “Mukha” or “Mylnitsa,” has appeared on the front line. It is used for remote mining of terrain using various types of UAVs.



It consists of two halves of a casing; when the cover is pressed, the force is transmitted to the pin of a homemade firing pin (an analog of the MUV), which, in turn, when the pin is pulled out, strikes the mine detonator (a homemade analog of the MD-5, assembled from a printed circuit sleeve, a primer, and a KD-8a). This triggers the explosion of the mine’s main charge (various types of explosives are used, primarily PVV-4, S-4, etc.). “Wings” are mounted on the other half of the casing to stabilize the mine during deployment.

The pin serves as a safety mechanism, preventing the mine from detonating during transport, and is pulled out of the mine casing upon deployment.



(through) hole for the safety pin pin



opening the mine casing



internal mechanism mine

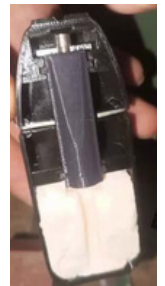

3D model of



3D sleeve with a primer fitted onto KD No. 8A



protrusions pressing on the firing pin and the release cap

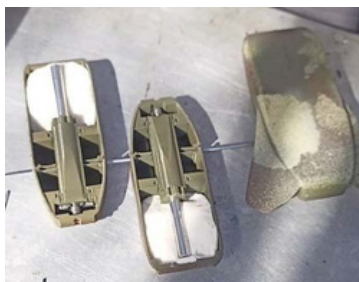

“Lugumina” anti-personnel mine (Ukraine)

In the fall of 2025, Ukrainian DIY enthusiasts unveiled their latest creation.



This mine is marketed as an anti-personnel/anti-vehicle mine with an electronic delay mechanism set to 2 minutes. It also features a self-destruct mechanism.

There is no data yet on the exact detonation time, but based on practical experience, it is likely around 20–30 days.



Dimensions (approximate):

- length 15–20 cm
- height/width: 3 cm
- weight: 60–90 g of plastic explosive

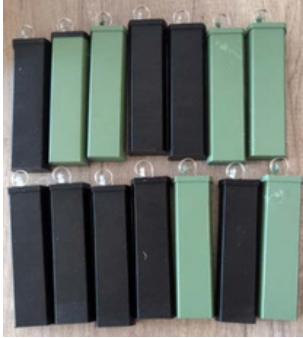

The mine is dropped from drones. Given its size and weight, it follows that the mines are dispersed from cluster munitions, which means that if one is detected, others will be nearby...

According to the enemy, the mine has passed field tests and has begun to be supplied to the troops.

“Ukrlepestok” Anti-Personnel Mine (Ukraine)

In the fall of 2025, the Ukrainians “invented” yet another anti-personnel mine. In essence, it is a Soviet-designed PFM-1-type mine, produced by hand.



The mine is used primarily as a payload dropped from drones for remote mining.

To do this, they again use a 3D printer (or even just plastic sheets and glue), an electric detonator, wire, a “pill”-type battery, plastic explosive (such as PPV-7), a piece of foil, and cardboard.

It's all, of course, quite simple and primitive, but it's clear they're at least trying to replenish their stockpiles of anti-personnel mines this way. They're also counting on our soldiers' inattention.

The mine contains approximately 10 grams of explosive, which is more than enough to inflict serious injury on anyone who steps on it.



How it works:

The mine's operation is extremely simple—when a person steps on the mine the contacts close, which in turn send a pulse to the electric detonator, causing the explosive to detonate.



Since this device is primarily used as a payload dropped from drones, if you spot one, you should carefully inspect the surrounding area—the rest will be nearby...

PPM-1P Anti-Personnel Mine (Ukraine)

In the fall of 2025, another new anti-personnel mine, manufactured using 3D printing, appeared on the LBS. There is very little information available about this device at this time.

Essentially, it is a prototype of the PMN mine, but it is triggered by a conventional electric detonator. The mine uses a standard lamellar switch.

A standard flat watch battery serves as the power source. A flat plastic strip (or even paper) acts as the safety mechanism. There are no other

safety mechanisms. It is possible that the mine may have a non-removable element ("jonik"). This element may also serve as a self-destruction mechanism.



Although using a "jonik" for such a mine is too great a luxury given their need for mines to deter our troops.

Main Specifications (approximate):

- Dimensions: diameter 8–10 cm
- Height.....3 cm
- Weight: mines.....100 g
- Explosive (plastic explosive) 40–50 g
- FuseEDP

It is possible that the enemy will further modernize them for use with drones....

It is quite likely that the mine is currently undergoing combat testing

“BOLT” Anti-Personnel Mine (Ukraine)

The enemy continues to come up with new homemade devices. And everything new is just the well-forgotten old. In this case, they’ve created a sort of prototype of the American C3A1 (A2) “ELSIE” mine, developed in 1962, only now using 3D printing.



The mine’s design is not particularly complex; the upper part of the mine appears to consist of a movable block secured by a pin to prevent downward displacement. When pressure is applied to the trigger mechanism, the entire block shifts, striking the detonator cap.

The detonator, along with the main charge, is housed in a separate block; it is presumed that the detonator is from an MDZ 12.7×108 cartridge and that the additional charge is a PVV charge.

The mine is set only manually.

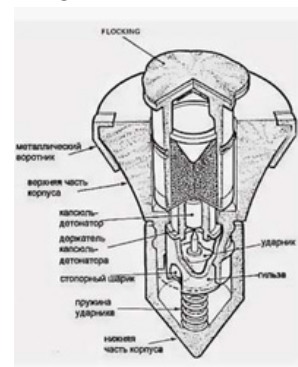

M25 "ELSIE" mine

Mine installation procedure:



- a) Unscrew the cap and remove the detonator charge (located in the same casing as the explosive);

- b) Turn the charge over and insert it back into the tube (with the primer facing the firing mechanism);

- c) Screw the cap back on;



- d) Insert the mine into a hole in the ground (you can use any stick to make the hole) up to the firing mechanism;
e) Remove the safety pin.

Due to the mine’s design (it is intended to be placed vertically) and the fact that it cannot be scattered, the likelihood of these mines being deployed over a wide area is low. The only places where they are likely to appear are narrow trails...

In July 2025, a video appeared online showing these mines being simply scattered across a field. It cannot be ruled out that the enemy has improved this mine so that the pin now holds a spring-loaded battery; when pulled out, the circuit closes and the MDV is triggered, after which either a vibration sensor or an impact sensor is activated, and upon impact or sudden movement, an electric igniter fires, directing a beam at the KD.

But it’s more likely that this is the work of very “experienced, trained” sappers.

The enemy isn’t standing still! Apparently, they have modernized this mine: adapted it for deployment from a UAV. The fuse has been replaced. It has become more sensitive to any movement. It appears to also have a mechanical trigger (of the metal-element type). Therefore, you must be very careful upon detection. If possible, it’s best to shoot it from a distance.

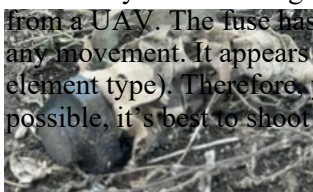

“Penal” Anti-Personnel Mine (Ukraine)

With each passing month, the Bandera-supporting sappers are inventing new types of munitions to target our soldiers. The main thing is that there be more 300-series mines.



To achieve this, they primarily use drones to manipulate magnetic fields, track movement, and so on.

And this year, a new type of munition has appeared, deployed from drones.

At first glance, it looks like an ordinary pencil case, a small tube. But it's loaded with an explosive—the TG-40. Or it could be any other explosive they have on hand.



The key component here is the Jonik; while its design is identical, it comes with different operating programs. This is a target sensor for remote mining using UAVs—the PDP.

The casing is made of plastic, 3D-printed.

There is a hole for the pin on top.

On the bottom is a hole for installing the KD and EDP. An accelerometer/magnetometer is likely installed inside.



According to available data (including photographs), the production of this munition and its associated fuse has been put on the assembly line...

It is possible that they could also use this fuse with other munitions... In addition, it appears that a ground-based remote mining system in the form of a cluster unit (analogous to the KSF).

HFM0050 anti-personnel drop mine (Ukraine)

Yet another “homemade device” found in the contact zone and nearby rear areas. As has become customary, the casing



is made of plastic using 3D printing (on 3D printers). According to enemy documentation, the munition is designated **HFM0050**. The mine is analogous to the S3A1 “Elsie” mine. It is described as a multipurpose device and contains a shaped-charge warhead. It can serve as:

- the warhead of an FPV drone (kamikaze) against personnel, unarmored vehicles, and cars;
- a drop payload for engaging unarmored vehicles and light armored vehicles;
- an engineering munition or anti-personnel mine. It

is already being actively used as a drop payload and as a mine dropped from drones.

Main Technical Specifications

Total weight including the safety fuse: 50–55 g
 Explosive.....10 g
 Detonator.....KD-N-19 (*probably also their semi-artisanal version*)
 Dimensions: length.....100 mm.
 Diameter.....40 mm
 Actuation force.....20 kgf.
 Hold-open force.....7.5 kgf.
 Safety features.....safety ring; calibrated spring.

General design:

1. cumulative charge;
2. cone;
3. housing;
4. retaining ring;
5. KD mounting sleeve;
6. spring;
7. tip;
8. target sensor;
9. safety catch;
10. rubber ring;
11. rubber ring.

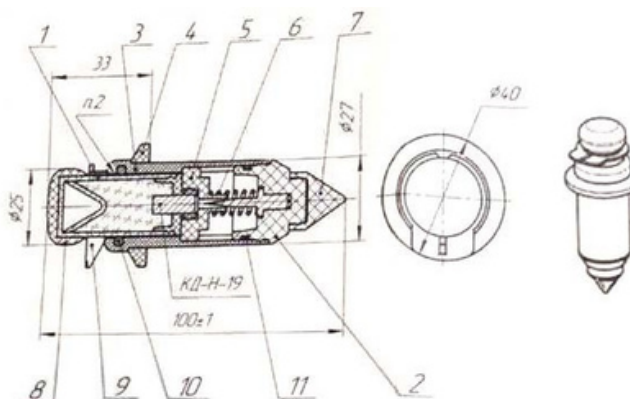

Combat use:

As a warhead for an FPV drone

In a hypothetical scenario involving a miniature FPV drone, the munition is mounted beneath it. The safety ring is removed. The UAV is launched. The operator detects the target and dives toward it. When the target sensor strikes an obstacle, this moving part comes to a stop, while the rest of the body continues moving due to inertia. The spring compresses, and the firing pin strikes



the primer. The charge detonates. The cumulative crater creates a projectile powerful enough to penetrate the thin roofs of many armored vehicles and APCs, not to mention unarmored vehicles. Even such a modest explosive charge is sufficient. A penetration can result in the driver or passengers being killed, the engine being disabled, a fuel fire, or the detonation of ammunition stored inside the vehicle.

Possibly, to increase the weight and effectiveness of the blast, an additional fragmentation jacket is provided, made of twisted steel wire that has been scored with an angle grinder so that it shatters more easily into fragments upon detonation.

Regarding deployment

In free-fall mode, the munition's center of mass pulls it toward the target sensor, but not with sufficient certainty. Therefore, for use as a drop bomb, the munition can be additionally loaded with several coils of steel wire on the side of the target sensor and secured with electrical tape. In this way, the munition falls with the target sensor facing downward. At the same time, the wire used for wrapping serves as additional striking elements.

When it strikes a car's roof or hood, it pierces through them and can injure occupants or ignite any flammable materials inside.

As an engineering munition (mine)

As an anti-personnel mine, it is simply installed by hand. The munition is thrust into soft soil, mud, sand, forest litter, or snow. Alternatively,

it is inserted into a hole dug with a knife in harder soils.

After installation and camouflage, the safety ring is removed, and the mine is armed.



Theoretically, these munitions could be modified for deployment by drones. But the center of mass would need to be shifted decisively toward the tip, somehow add extra weight. And it will only work on soft surfaces. It simply won't penetrate hard surfaces. Once the tip is embedded, the mine stands vertically, with the pressure sensor facing upward. Applying 20 kg of force is enough to trigger an explosion. The explosive charge is sufficient to cause a foot injury. Taking the cumulative charge into account, the injuries could be even more severe.

The danger of this munition lies in its innocuous appearance. It looks like some kind of obscure part—a plastic component from some piece of equipment or machinery—or a plastic bottle cap pushed into the ground... It does not look like an explosive device unless you know what it is.

This mine is used in the Donetsk theater of operations

“STIK-F” (Stick IB) engineering munition (U.S.-Ukraine)

The Stick IB engineering munition was developed specifically for use with remote mining systems employing “Baba Yaga”-type UAVs to engage personnel in modern combat conditions.



Main Specifications:

Weight: of the munition.....	320 g
Explosive (Anemix-P).....	110 gr.
Dimensions: diameter.....	38 mm
Length.....	195 mm
Discharge height.....	up to 50 m
Operating temperature range.....	-20 – +40°C

An electric detonator is used for detonation.

The munition has three levels of protection: two mechanical and one electronic.

Activation mechanism: triggered by a change in the magnetic field or displacement; activation range for a metal object: ≥ 0.3 m. Self-destruction timer (TMS): programmable, from 5 to 60 days (parameters are agreed upon with the customer for each batch).

Self-destruction principle: triggered by the timer (TMS) or when the battery reaches a critical charge level.

Effect (ground): 10×10 cm crater



A dedicated mounting and release system for this munition was developed for use with UAVs. STICKS KMPs is a comprehensive remote-mining system, developed in collaboration with combat units, specifically to the needs of modern high-tech warfare.

The solution enables the rapid and precise deployment of engineering obstacles by UAVs without the direct involvement of sappers, minimizing risks to personnel and ensuring a complete safety cycle—from deployment to combat readiness and controlled self-destruction.



Capacity of cassettes and modules:

- Stick cassettes: up to 6 Stick IB engineering munitions.
- Stick MPS release module: up to 2 cassettes (up to 12 munitions total).
- Deployment modes: at least 2 at a time (1 from each cassette); with a single cassette—1 at a time; automatic sequential mode is available.

Packaging (48 pcs.): gross weight $30 \text{ kg} \pm 3$



Therefore, if even a single piece of this ammunition is found, you should exercise increased vigilance and caution: similar ammunition will be nearby!

BLU-43/B “Dragontooth” (USA)

The BLU-43/B (“Dragontooth”) is an American pressure-activated anti-personnel mine with a chemical deactivation mechanism, serving as a submunition in an aerial cluster munition. The Bomb Live Unit (BLU-43) and its later variants are deployed on the ground exclusively via remote-controlled mining systems and are designed to neutralize enemy personnel by injuring their feet when they step on the mine, as well as certain types of vehicles when they drive over it. The BLU-43 earned the nickname “*toe popper.*” The BLU-44/B and BLU-44A/B variants differed from the BLU-43/B only in their deactivation mechanism.



Main Technical Specifications

Casing material.....	polyethylene
Mine weight: total.....	20 g
Explosive (nitromethane-nitroethane).....	9 g
Dimensions: length.....	7.3 cm
width.....	4.6 cm
thickness.....	1.4 cm
Pressure-sensitive DC.....	3.8 × 2.0 cm
Actuation force of the push-button DC.....	about 7 kg
Time to ready for firing.....	10–30 sec after ejection from the cassette
Operating temperature range	+1° – +56° Self-
neutralization (self-destruction) time.....	14–35 days
Self-destruction/Self-neutralization BLU-43/B.....	No/Yes
BLU-44/B; BLU-44 A/B.....	yes/yes
Number of mines per cassette.....	120 pcs.



The mine consists of a semi-soft polyethylene casing with a complex geometric shape. The central part is cylindrical in shape. It houses the fuze. On one side, the casing resembles a flat petal; on the other, it forms a chamber filled with 9 grams of liquid explosive (nitromethane and nitroethane). The asymmetrical, winged casing allows the mines to glide to the ground without a parachute. The wing on the larger side of the casing serves to ensure a greater dispersion across the terrain and to reduce their landing speed (to prevent damage upon impact with a hard surface, especially when dropped from significant heights).

Note: Nitromethane and nitroethane are products of the treatment of propane with nitric acid. They are formed simultaneously during the reaction and then separated by fractionation. In practice, they are mainly used as solvents. Both are flammable and explosive, but are not classified as explosives per se.

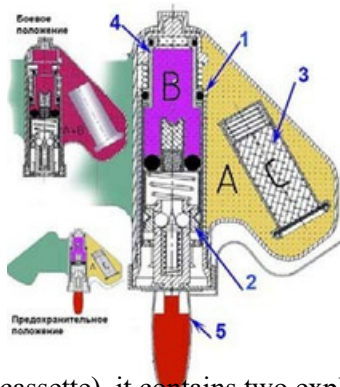

The detonator consists of an aluminum tube (1) containing a percussion-trigger mechanism (2). The mine’s casing is filled with the first component of the liquid explosive (A). In addition to the explosive, it also contains an aluminum capsule (3) holding a neutralizing agent (C), which is a mixture of methanol and propylenediamine. The capsule is sealed with a soluble cap, and the neutralizing composition is spring-loaded. The upper part of the casing is sealed by a spring-loaded piston (4), which separates the second component of the explosive (B), located in the upper part of the fuse casing. This piston is prevented from moving by a safety device (5).

Thus, while the mine is in the safety position (inside the CDU-2/B cassette), it contains two explosive components, neither of which is an explosive on its own.

Once the mine is ejected from the CDU-2/B cassette, the locking lever is released. This allows the spring to move the piston and open a passage from the chamber containing liquid “A” to the chamber filled with liquid “B.” When mixed, the two liquids form a liquid explosive. From this point on, the mine is in a combat-ready state.

If pressure is then applied to the mine’s casing (an enemy soldier steps on the mine), the liquid explosive, acting as a hydraulic fluid, will push the detonator cap and its holder downward. This will release the balls holding the striker in place. The released striker strikes the detonator cap, causing the mine to explode.

Once the BLU-43/B mine is armed—that is, once the two liquids have been mixed to form the explosive—this same mixture begins to dissolve the lid of the aluminum capsule located inside the mine’s cavity. As soon as the cap dissolves (which will occur in a minimum of three and a half days and a maximum of thirty-five days), the capsule’s spring will push a chemical reagent into the cavity, which will react with the explosive and convert it into a neutral substance. In other words, the mine will self-neutralize. It should be noted, however, that the detonator capsule is hermetically sealed and does not undergo neutralization. Thus, the mine remains somewhat dangerous even after self-neutralization. Self-neutralized mines must be collected and destroyed by incineration.



The mines utilized a chemical self-neutralization system that rendered the main explosive charge inert some time after activation. However, the reliability of this mechanism is largely unknown.

The BLU-44/B and BLU-44A/B mines do not self-neutralize but rather self-destruct. The mine’s neutralization capsule contains borohydride chloride and copper chloride. Sodium borohydride (after the capsule cap dissolves) begins to react with the methanol and water present in the explosive, producing hydrogen, which generates sufficient internal hydraulic pressure to trigger the detonator. If this does not occur, the increasing hydraulic pressure ruptures the casing, and the explosive leaks out, where it is absorbed into the soil and evaporates. If the casing does not rupture, the copper chloride subsequently reacts with the explosive, converting it into a neutral substance.

There are no external signs indicating whether the mine is active or neutral.

The mines may be olive, yellowish-brown, brown, or camouflage in color, without any painted or molded markings. Inert (training) mines are blue. Alternatively, a blue stripe may be painted on the wing.

Although the mine was not officially adopted by the U.S. Armed Forces, it was widely used during the Vietnam War from 1967 to 1975 and was the primary type of American mine used for aerial mining.

There have been reports of these mines being used by the Ukrainian Armed Forces, but the exact location of their discovery is unknown.

YM-1 Anti-Personnel Mine (Iran)

The YM-1 anti-personnel mine is essentially an Italian high-explosive anti-personnel mine manufactured in Iran but marketed under the name YM-I.



The YM-I mine, designed to target personnel, is intended for mechanized deployment by scattering it across the ground, including from helicopters. It can be deployed manually both on the surface ground or buried in the ground under camouflage

a layer up to 3 cm thick. The mine is sufficiently resistant to impacts and blast waves.

Its watertight design allows it to be used in water-saturated marshy soils.



Technical Specifications of the YM-1 Mine

Mine Type.....	High-explosive
Total weight.....	203 g
Explosive (RDX - Hexogen).....	52 g
Dimensions: diameter.....	90 mm
Height.....	48.5 mm
Target sensor diameter.....	35 mm
Actuation force	7–12.5 kgf
Stroke of the pressure cap before the fuze is triggered.....	5 mm



- 1 – Предохранительная крышка
- 2 – Верхняя накидная гайка
- 3 – Донная часть
- 4, 6 – Нажимные крышки
- 5 – Запал
- 7 – Гнездо запала
- 8 – Заряд ВВ
- 9 – Корпус
- 10 – Колпачок
- 11 – Боевая пружина
- 12 – Ударник
- 13 – Втулка
- 14 – Предохранительная пружина
- 15 – Коромысло
- 16 – Крышка
- 17, 18 – Резиновые балончики
- 19 – Элементы диафрагменной втулки

The mine consists of a plastic casing (yellow-brown in color), an explosive charge (EC), and a detonator (D). The mine casing is cylindrical in shape, with threaded outer walls at the top and bottom. A base section is screwed onto **the bottom** of the casing. In the center of the base is a threaded hole for installing the fuse (detonator cap). A rubber pressure cap is placed on **top** of the body and secured to it with an upper cap nut.

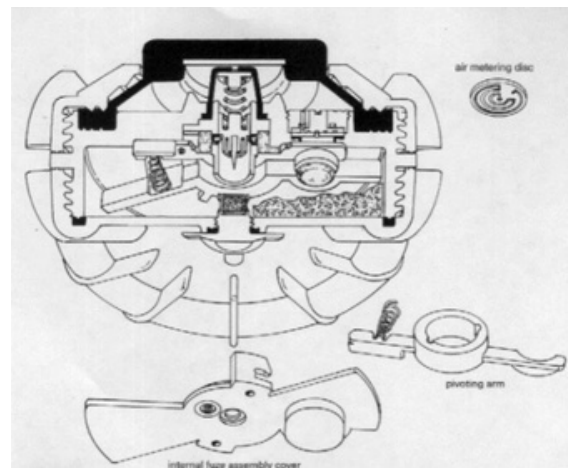

To increase rigidity, the pressure cap has a metal insert on the back side. The mine's marking is stamped on the outside in the center of the cap. In the transport position, the pressure cap is covered by a safety cap, which is secured to the upper cap nut using two locking pins. Stiffening ribs are located around the perimeter of the upper cap nut and the base.

The explosive charge is located in the lower part of the casing and consists of a shaped cylindrical block of phlegmatized hexogen. A hole is machined in the center of the block, coaxial with the threaded bore for the fuse in the bottom of the casing. In the center of the mine's casing, beneath the pressure cap, is an opening for housing the components of the detonator's striking mechanism: a main spring covered by a rubber cap on top, a striker, and a sleeve with balls that hold the striker in a safe position. On the rear side of the casing, a rocker arm is fitted over the sleeve with balls and the striker; one arm of the rocker arm is spring-loaded by a safety spring. The rocker arm and spring are covered by a cap. The other arm presses against an inflatable rubber bladder, which is connected via elements of the diaphragm sleeve to an air passage located eccentrically on the mine's body. If a load is applied to the pressure cover (for example, by stepping on it), it will flex and compress the main spring. At the same time, the air pressure in the cavity beneath the pressure cap will increase. Through the relief port and the labyrinth in the diaphragm sleeve components, air will flow into the rubber bladder. As the bladder expands, it will press against one arm of the rocker and turn it counterclockwise. The other arm of the rocker arm will compress the safety spring, and its central section will rotate around the sleeve containing the firing pin in such a way that the balls holding the firing pin in place will drop into the grooves of the rocker arm's central section. The firing pin will be released and, under the action of the main spring, will strike the fuse, causing the detonator and the mine's charge to explode. Some variants of this mine are equipped with an electronic fuse featuring a self-destruction unit and anti-removal elements, which cause the armed mine to detonate if an attempt is made to change its position. In these variants, the letters "AR" are added to the mine's designation. Such high-explosive mines may vary in the mass of their explosive charge. All parts of the mine, with the exception of the pressure cap insert, the main and safety springs, the two balls, and the striker, are made of non-metallic materials. Therefore, detecting these mines with induction mine detectors is difficult.

The mine is not equipped with a self-destruct mechanism. It has no non-removable elements, but its design features prevent the mine from being reset from the armed to the safe position.

The virtually complete absence of metal parts makes it absolutely impossible to detect the mine with induction metal detectors, and the mine's thorough sealing drastically reduces the smell of explosives emanating from it, which also makes it more difficult for dogs to detect the mine. The high sensitivity of the target sensor makes it impossible to locate these mines using probes.

Colors: yellow-brown, sand, green, camouflage.

Markings: applied in white paint on the pressure cap and includes: - YM-I – the mine's code.

According to Ukrainian sources, these mines were purchased by the Syrian Ministry of Defense and have been supplied to the DPR and LPR via Russia since November 2017.

There have been reports of these mines being detected by our sappers in the LPR.

YM-IB anti-personnel mine (Iran)

This is the Italian VS-50 high-explosive anti-personnel mine, manufactured in Iran under the name YM-IB. It is a pressure-activated anti-personnel blast mine. It is designed to neutralize enemy personnel. It features a waterproof plastic casing with reinforcing ribs. The mine's watertight design allows it to be used in water-saturated and marshy soils.



Due to the mine's buoyancy, the water level must not exceed 2 cm from the bottom of the mine. The mine's fuse is pneumatic and blast-resistant. The minimum distance between mines at which detonation of

of adjacent mines (in the event that one of them explodes) is 10 m.

The YM-1(B) mine uses the same casing as the earlier Iranian YM-1 mine; however, there is currently no information available regarding the full range of colors used for the mine casing.

Externally, both mines

look identical, with the exception of a switch on the underside of the YM-1(B) mine, next to the detonator socket, which serves as an additional protective mechanism ensuring complete disengagement of the internal explosive circuit components, and the stamped marking on the mine's pressure cap featuring the designation YM-1 and the letter B in a circle.

The stenciled markings on the underside of the mine include the designation YM-1-B, the date of manufacture, and the lot number.

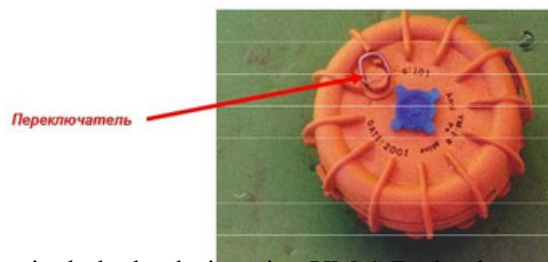

Technical Specifications of the YM-1B Mine

Weight: total.....185 g
 Explosive (TNT/RDX, RDX) 42–45 g
 Dimensions: diameter.....9 cm
 Height.....4.5 cm Target
 sensor diameter.....3.5 cm Actuation
 force.....10 kg

The injury is caused by the destruction of the lower part of the leg (foot) when the mine's charge detonates the moment the foot steps on the mine's target sensor (a black, round protrusion on the upper surface). Typically, when a mine explodes, the foot of the enemy soldier who stepped on the mine is completely severed, and, depending on the distance of the other foot from the blast site, it may also be significantly injured or remain unharmed. Death may result from pain shock or blood loss if first aid is not administered promptly.

The mine casing is made of impact-resistant plastic and consists of two parts connected by a glue-threaded joint. The ribs on the mine casing are designed to increase its strength. The mine is switched from the safe position to the live position by pulling out the safety pin.

To manually arm the mine, screw the M 41 detonator into the hole in the center of the lower part of the casing and

remove the safety pin. From that moment on, the mine will be in the live position. When the mines are dropped from a helicopter, a safety "cap" is placed over the pressure sensor, which prevents the mine from detonating upon impact with the ground (since the safety pin has already been removed). The safety pin and "cap" are clearly visible in the photo on the right.

The casing can be khaki, brown, green, or sand-colored.

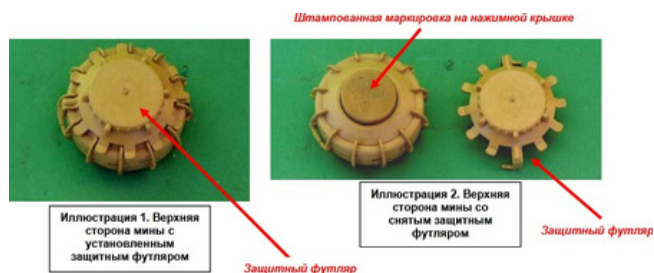

The virtually complete absence of metal parts (with the exception of a small spring and a striker) makes it virtually impossible for metal detectors to detect the mine, and the mine's thorough sealing drastically reduces the smell of explosives emanating from it, which also makes it difficult for dogs to detect the mine. The high sensitivity of the target sensor makes searching for these mines with probes a deadly dangerous task.

The mine is highly resistant to explosive demining devices, including elongated demining charges such as the Soviet UZ and charges containing volume-detonating mixtures. The YM-IB's resistance to detonation from a neighboring mine of the same type extends to more than 10 meters.

According to Ukrainian sources, these mines were purchased by the Syrian Ministry of Defense and have been supplied to the DPR and LPR via Russia since November 2017.

There have been reports that our sappers have detected these mines on the territory of the LPR.

TS 50 Anti-Personnel Mine (Italy)

The TS50 mine, designed to target personnel, is intended for mechanized deployment onto the ground surface by scatter, including from helicopters. It can also be deployed manually, either on the ground surface or buried beneath a camouflage layer up to 3 cm thick. The mine is sufficiently resistant to impacts and blast waves.



TS50 Mine Specifications

Mine Type.....	High-explosive
Total weight.....	203 g
Explosive (phlegmatized hexogen).....	52 g
Dimensions: diameter.....	90 mm
Height.....	48.5 mm
Actuation force	7–12.5 kgf
Stroke of the pressure cap before the fuse is triggered.....	5 mm



The mine consists of a plastic casing (yellow-brown in color), an explosive charge (EC), and a detonator (D). The mine casing is cylindrical in shape, with threaded outer walls at the top and bottom. A base section is screwed onto **the bottom** of the casing. In the center of the base is a threaded hole for installing the fuse (detonator cap). A rubber pressure cap is placed on **top** of the body and secured to it with an upper cap nut.

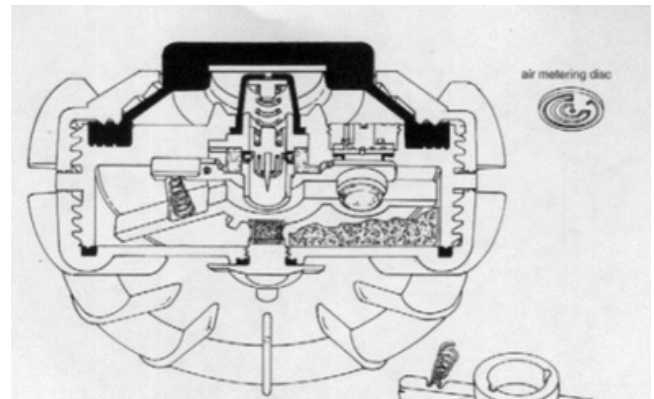

To increase rigidity, the pressure cap has a metal insert on the back side. The mine's markings are stamped on the outside in the center of the cap. In the transport position, the pressure cap is covered by a safety cap, which is secured to the upper cap nut using two locking pins. Stiffening ribs are located around the perimeter of the upper cap nut and the base of the casing. **The explosive charge** is located in the lower part of the casing and consists of a shaped cylindrical block of phlegmatized hexogen. A hole is machined in the center of the block, coaxial with the threaded bore for the fuse in the base of the casing.

In the center of the mine's casing, beneath the pressure cap, there is an opening for the components of the detonator's striking mechanism: a main spring covered by a rubber cap, a striker, and a sleeve with balls that hold the striker in a safe position. On the rear side of the casing, a rocker arm is fitted over the sleeve with balls and the striker; one arm of the rocker arm is spring-loaded by a safety spring. The rocker arm and spring are covered by a cap. The other arm presses against an inflatable rubber bladder, which is connected via elements of the diaphragm sleeve to an air passage located eccentrically on the mine's body. If a load is applied to the pressure cover (for example, by stepping on it), it will flex and compress the main spring. At the same time, the air pressure in the cavity beneath the pressure cap will increase. Through the relief port and the labyrinth in the diaphragm sleeve components, air will flow into the rubber bladder. As the bladder expands, it will press against one arm of the rocker and turn it counterclockwise. The other arm of the rocker arm will compress the safety spring, and its central section will rotate around the sleeve containing the firing pin in such a way that the balls holding the firing pin in place will drop into the grooves of the rocker arm's central section. The firing pin will be released and, under the action of the main spring, will strike the fuse, causing the detonator and the mine's charge to explode.

Some variants of this mine are equipped with an electronic fuse featuring a self-destruction unit and anti-removal elements, which cause the armed mine to detonate if an attempt is made to change its position. In these variants, the letters "AR" are added to the mine's index. Such high-explosive mines may vary in the mass of their explosive charge.

All parts of the mine, with the exception of the pressure cap insert, the main and safety springs, the two balls, and the striker, are made of non-metallic materials. Therefore, detecting these mines with induction mine detectors is difficult.

This mine was detected in the Eastern Military District by sappers from the Karbyshev Battalion

Mi-AP-DV 59 Anti-Personnel Mine (France)

As early as the 1950s, France developed a series of anti-personnel high-explosive mines with pressure-sensitive fuses of the tear-type. These include the Mi-AP-DVS1, Mi-AP-DV 56, Mi-AP-DV 59, Mi-AP-DV 61, and Mi-AP-DV 63.



Among these mines, the best known is the Mi-AP-DV 59, sometimes referred to simply as the 1959 model (M-59) or “Inkstand.” It was adopted for service in 1959.

In the 1960s, the French Army deployed large quantities of these mines in Algeria, Tunisia, and Morocco. It is evident that some stockpiles of these mines remain in a number of countries in Africa and Southeast Asia, despite the fact that many countries, although they have ratified the Convention, have no intention of



comply with its requirements.

It is unknown how or in what quantities these mines ended up in the Ukrainian Armed Forces. It appears that the French are simply clearing out their warehouses and found the remnants of these stockpiles somewhere.

Main Technical Specifications of the MI AP DV 59 Mine

Mine type.....	anti-personnel high-explosive pressure-activated
Casing material.....	polyethylene
Mine weight: total.....	130 g
Explosives (tetryl and TNT).....	70 g
Mine dimensions: diameter.....	6 cm
Height (to the top of the fuze).....	6 cm
Height (without fuze).....	3.2 cm
Diameter of the pressure disc.....	2 cm
Actuation force of the push-button detonator.....	5–25 kg
Time to arm	immediately after removing the safety cap
Time to set the mine.....	5–10 min.
Operational life.....	Unlimited
Operating temperature range	-40 – +50°C
Fuse.....	AL PR ID59withR54orID56detonator
Defusing/extraction capability.....	Yes/Yes
Self-destruction/self-neutralization	No/No

This mine is one of the first mass-produced mines with a chemical fuse, which is why it has been copied in several European countries.

Structurally, the mine consists of a cylindrical polyethylene casing (1) with a threaded socket at the top for the fuse (2) and the detonator (3). In the main cavity of the casing, surrounding the fuse socket, there is an intermediate

detonator (4) made of 15 grams of tetryl and a main charge (5) of 55 grams of fused TNT. On the upper surface of the casing, on the outside, there is a removable metal disc (6) pressed against the casing by the fuse.

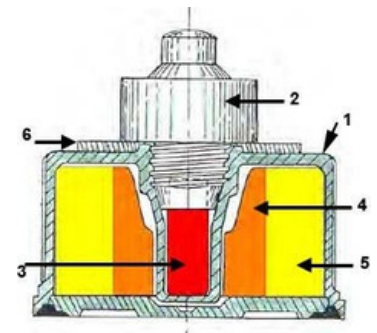

A plastic cover with three ribs serves as a safety mechanism in the transport position, preventing the detonator button from being pressed. When removed, the mine is armed. This mine contained no metal parts whatsoever and could not be detected by any metal detectors; therefore, to ensure it could be located by the unit’s own sappers, a metal ring—the “detector ring”—was installed around the detonator. However, this ring can be easily removed.

The AL PR ID 59 fuse is constructed as follows:

If pressure exceeding 5–25 kg is applied to the head (3), it moves downward together with the plunger (5), crushing the collar (4) and piercing the diaphragm (9). This causes friction between the ignition composition (7) and the grinding composition of the cup (6). This leads to a flash of flame, which is amplified by the flame amplifier (8). The force of the flame enters the connector and detonates the detonator. This, in turn, detonates the intermediate detonator and the mine's main charge.



AL PR ID 59

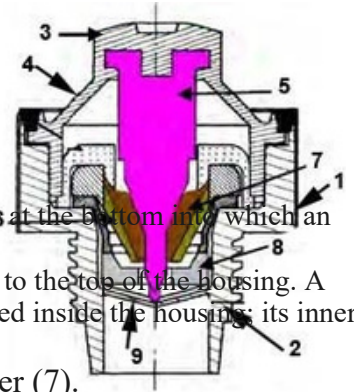

A threaded housing (1) designed to be screwed into the mine, with a fitting (2) at the bottom into which an R54 or ID 56 detonator is inserted.

A head (3) made of flexible plastic, featuring a crushable collar (4), is secured to the top of the housing. A plunger (5) with a needle is secured inside the head. A conical cup (6) is secured inside the housing; its inner walls are coated with a grating compound. This cup is filled with a gel-like ignition compound consisting of red phosphorus and glass powder (7).

An ignition booster (8) (potassium chlorate) is located beneath the cup.

The bottom of the housing, containing the ignition compound and the flame booster, is hermetically sealed by a diaphragm (9).

Mine Installation Procedure:
Remove the safety cap and unscrew the fuse from the mine. Insert the detonator into the mine's socket. Screw the fuse back into the mine and replace the safety cap on the fuse. Place the mine in a hole or on the surface. Remove the safety cap from the fuse. The mine is now armed.

Mine neutralization or destruction:

To defuse a mine, install the safety cap, after which the mine is removed from its location. Next, unscrew the fuse, turn the mine over, and shake the detonator out onto your palm. After that, screw the fuse back into place and install the safety cap. If there is no safety cap, perform all the steps described above, except for those involving the safety cap.

The mine is destroyed at the site of discovery using a 200-gram charge of plastic explosive applied to the side of the mine. It is best to follow Russian standards, which do not provide for the neutralization of any anti-personnel mines (except for guided ones). The mine should be destroyed at the site of discovery using an external explosive charge.

Mine color: Army green or sandy yellow. Training mines are painted blue.

The mine can be used with a special device consisting of a plastic rod with an anchor pin at one end—featuring spring-loaded prongs that spread apart—and a mine cup at the other end.

The device is driven into the ground at the desired location, and then the mine is placed into the cup and secured with a special pin.

The rod is 15 to 25 centimeters long. The device is not included with the mine and is sold separately.

This device is designed to prevent the mine from shifting if:

- the mine is placed in water (at the bottom of a ford);
- the mine is placed on a slope where heavy rain runoff is common;
- the mine is installed in loose sandy soil.



This mine was discovered in the Eastern Military District by sappers from the Karbyshev Battalion

RMA-2 anti-personnel mine (Yugoslavia)

The PMA-2 is a Yugoslav pressure-activated anti-personnel high-explosive mine. It is sometimes referred to as



“Pâté.” Because of its similarity in size to a can of meat pâté, the mine has acquired the slang name “pâté,” which is known to sappers in every country. The mine is made of dark green plastic (or polystyrene) and has a distinctive plunger, from which six petals radiate.

In the center of the cylindrical part of the casing, there is a threaded hole; the central socket of the fuze is closed with a plug when the mine is in its transport seal and contains a small

hexogen charge serving as an intermediate detonator.



Main Technical Characteristics of the PMA-2 Mine

Mine Type.....Anti-personnel high-explosive pressure-activated
 Casing material.....plastic
 Mine weight: total.....135 g
 Explosive (TNT).....100 g (70 g of hexogen)
 Mine dimensions: diameter.....6.8 cm
 Height.....6.1 cm Target sensor diameter.....about 3 cm
 Sensitivity 7–15 kg.
 Main fuse UPMAH-2

The UPMAH-2 fuse consists of a plastic housing (3) that screws into the mine’s threaded socket and a

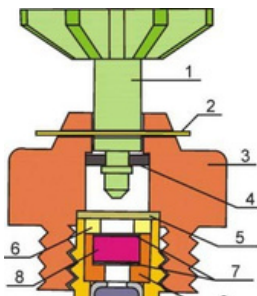

plastic plunger (1), the upper part of which is fitted with a six-pointed star-shaped extension. This star can be easily removed from the plunger.

Below the plunger, beneath the diaphragm, is a friction-sensitive pyrotechnic (grinding) composition (8), and beneath that is an M-17P-2 detonator (10). A significant drawback of the mine is its chemical fuse.

Friction-sensitive pyrotechnic compositions are generally very sensitive to moisture

(they lose their properties), and it is not always possible to prevent the by thoroughly sealing the fuse, which in itself is extremely difficult to achieve with readily available methods. But even if the fuse is successfully sealed, there is always a risk of moisture from the air condensing inside the fuse when daily temperatures cross the dew point. However, the reverse process of condensate evaporation often does not occur or proceeds extremely slowly



The detonator, which has a thin aluminum casing, is connected to the detonator body by a sleeve (11). The detonator charge consists of 7 grams of compressed TNT in paraffin.

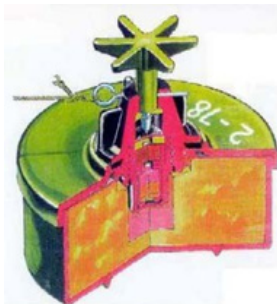

Below it is an intermediate detonator in the form of a 2-gram block of compressed tetryl (or RDX). This intermediate detonator is part of the mine, not the detonator assembly.

The safety pin (2) passes through the detonator housing and the plunger, preventing the plunger from shifting downward and initiating the friction-sensitive pyrotechnic composition. The mine is ready for use after the safety pin is removed; it does not have a remote arming system.

The use of a star-shaped plunger gives this mine a high degree of resistance to explosions. The plunger and mine casing are typically

olive green, although white mines with a black fuse casing are sometimes encountered.

When an enemy soldier's foot presses against the star-shaped top of the plunger, the plunger shifts downward, activating the friction-initiated pyrotechnic charge, which ignites and triggers the detonator, causing the mine's main charge to explode. Although the explosion of a PMA-2 mine is unlikely to be fatal, it usually blows off the victim's leg, thereby resulting in some form of permanent disability affecting their gait.

Mine Installation and Operation.

To arm the mine, unscrew the plug from the fuse socket and screw the UPMAH-2 fuse into it.

After placing the mine in a hole and partially camouflaging it, pull the cord to remove the safety pin from the fuse. From this point on, the mine is armed, and the camouflaging process should be completed carefully, without touching the plunger.



PMA-2 mines are usually buried so that only the star-shaped plunger is visible above ground. However, although this mine is not completely concealed (unlike many others), it is very difficult to detect, especially in dense underbrush or fallen leaves.

This mine can also be laid in other ways to make visual detection and/or the demining process more difficult. For example, PMA-2 mines are sometimes laid completely upside down, with only one centimeter of the base protrudes from the ground. Alternatively, they can be buried diagonally relative to the ground surface so that the star-shaped plunger (now completely hidden underground) faces the deminers' detection sensor.

In addition, to increase the detection area, a cover can be made for the same purpose.

There have been reports of the star's "petals" breaking off when pressed, as it is made of plastic that is not strong enough.

Sometimes, to increase the explosive power, an additional explosive charge or another RMA-2 mine without a fuze is placed under the mine.

The mine is airtight, and when properly installed and under favorable external conditions (soil moisture, precipitation, etc.), it remains operational for a long time. If these conditions are not met, half of the mines that have been in the ground for two years lose their functionality due to moisture entering the fuse through the star-shaped igniter via the rubber seal. As a result, the sensitive pyrotechnic composition becomes damp and ceases to react to mechanical stress.

Neutralization

The mine has no self-destruction or self-neutralization mechanisms. Neutralization is achieved by inserting a safety pin or a piece of wire 3–4 cm long, matching the diameter of the hole, into the opening on the side of the detonator.

Disarmament

Due to its strong odor, the mine is very easily detected by dogs. Wild boars and foxes show interest in it. For some reason, foxes like to drag them through the forest, thereby creating a great danger to people.

The mine is virtually undetectable by metal detectors, since the only metal part is the aluminum casing of the detonator.

To defuse this mine, insert a wire of the appropriate diameter (1.5–2 mm) into the side hole of the detonator; bend the ends of the wire in opposite directions to prevent it from accidentally falling out of the detonator. The fuse is then unscrewed from the mine, and the detonator cap is separated from it. When defusing the mine, pay special attention to the position of the fuse stem. If it is slightly lowered along with the star (in which case it is impossible to insert the wire into the hole), this indicates that the pin may be within the range of the explosive-ignition mixture, and an explosion may occur when attempting to pull the pin back out. Defusing such a mine is not recommended. As a last resort, carefully unscrew the detonator from the mine and remove

the detonator cap from it. Only after that, if you really want to, can you try to determine the reasons for the fuse's failure to fire. Usually, there is only one cause: the pyrotechnic mixture has become damp.

The likelihood of a trap being set for unloading is low due to the mine's light weight (minimum unloading weight: 3 kg) and has never been observed in practice.

The procedure for neutralizing an RMA-2 mine is as follows:

- 1) remove the camouflage layer from the mine and clear the sides;
- 2) remove the mine from its location;
- 3) insert a safety pin or a piece of wire of suitable diameter into the hole on the side of the fuse;
- 4) unscrew the fuse from the mine;
- 5) check the installation site for any additional explosive charges.

This mine was discovered by sappers from the Karbyshev Battalion

M18 “Claymore” anti-personnel mine (USA)

A guided, directional-effect anti-personnel fragmentation mine. Designed to



neutralizing enemy personnel. It inflicts injury on a person by embedding ready-to-explode projectiles into the body.

It was adopted by the U.S. Army in 1962.

The mine was developed as a means of combat security for strongpoints and outposts of U.S. units in Vietnam. These mines were laid along the approaches to strongpoints and detonated at the threat of an enemy approach or even at the slightest rustle. The mine proved to be highly effective and significantly reduced Viet Cong activity in

areas around strongpoints and helicopter landing zones. During the war, a more advanced version was developed under the designation **M18A1** (in 1964).

The mine can be placed on the ground or attached to local objects (posts, walls, tree trunks, etc.) by hand. The latter can be done only with improvised tools. Installation using mechanized means is not provided for. The mine can remain in saltwater or freshwater for up to 2 hours.



The mine has an unlimited operational life. It does not possess features designed to prevent removal, neutralization, or self-destruction.

It consists of a rectangular box made of glass-fiber-reinforced polystyrene, curved forward. Inside is a charge of Composition 4 plastic explosive (C4 consists of 91% hexogen and 9% plasticizer, with a TNT equivalent (RE) of 1.34) weighing 680 grams.

The front of the mine is marked: “FRONT TOWARD ENEMY.” The back is marked: “BACK” and other markings.

Inside the box, along its forward-curving front wall, is a plastic plate into which 700 steel balls (5.4 mm in diameter, 0.68 grams each) have been embedded. Two pairs of steel extendable legs are riveted to the bottom of the box for placing the mine on the ground.

On the upper surface, in the center, there is a simple frame-type sight for aiming the mine, and to the left and right of it are two sockets for an M4 electric detonator, which is similar to the M6 electric detonator and differs only in that it has a 30-meter-long wire. The sockets for the electric detonators are positioned at a 60-degree angle and are covered with screw-on adapter plugs.

Technical Specifications of the M18A1 Mine

Mine Type.....	Anti-personnel fragmentation mine with directional effect, controlled by
May	
Casing	plastic
Warhead.....	700 steel balls (diameter 5.4 mm, weight 0.68 g)
Mine weight (without accessories).....	1.59 kg
Explosive charge weight (C4).....	680 gr.
Overall length.....	21.6 cm
Overall height (with legs folded).....	8.26 cm
Case thickness.....	3.5 cm
Operation.....	Detonation via an electrical pulse from an M57 detonator
Length of the target tension sensor.....	20 m
Effective range up to 50 m (actual effective range no more than 20–30 m)	Horizontal
dispersion angle of the projectiles.....	60°
Height of the strike zone at maximum range.....	more than 4 m.
Projectiles.....	700 steel balls

with a diameter of 5.4 mm.

Minimum permissible distances from other mines:

- 50 meters in front of or behind another M18A1 mine;
- 3 meters to the side of an adjacent M18A1 mine;
- 10 meters from anti-tank mines or fragmentation anti-personnel mines
- 2 meters from high-explosive anti-personnel mines

The mine kit includes:

1. The mine itself.
2. The compact M57 blasting machine.
3. M40 tester (one for six mines)...
4. M4 electric detonator kit (M6 electric detonator and 30 meters of insulated wire).
5. Bag.



According to the instructions, the mine is primarily used in the guided mode. It is placed on the ground or attached to a nearby object (a pole, tree trunk, etc.) so that the convex side faces the enemy. Using a sight, the operator aims the mine and determines the blast radius. The operator inserts an electric detonator into one of the two sockets and secures it with an adapter plug.

The wire must first be unwound to its full length (30 m) and extended slightly toward the location where the detonation station will be set up.

The operator then connects the tester to the other end of the wire via a connector and connects the detonator to the tester.

By pressing the trigger on the detonator, the operator checks that the electric detonation circuit is functioning properly (the indicator on the tester should light up).

To detonate the mine, connect the detonator directly to the wires and press the lever sharply.

When the mine explodes, it releases a stream of steel balls that fly in a horizontal arc of approximately 60 degrees, reaching a distance of up to 250 meters.

The balls retain their lethal force up to 100 meters, but the maximum effective range is 50 meters. At greater distances, a ball striking a person can only be accidental.



The mine is used by Ukrainian fascists on battlefields across all areas of combat, as well as by sabotage and reconnaissance groups during a terrorist attack in the Bryansk region in March 2023.

MRUD Anti-Personnel Mine (Yugoslavia)

A Yugoslav guided anti-personnel fragmentation mine with directed effect. It was developed in the early 1970s in Yugoslavia. It was adopted by the Yugoslav Army. It is designed to neutralize enemy personnel.



When the mine explodes, it inflicts damage on a person (or several people simultaneously) using preformed lethal elements (steel balls) that are propelled toward the enemy within a 60° horizontal sector at a range of up to 50 meters. The operator triggers the explosion from a control panel when an enemy appears within the engagement sector. Various MUV-series (MUV-1) tripwire fuses, or other types, may also be used. In this case, the mine becomes unguided.

It is a greatly simplified version of the M18A1 mine and the Soviet MON-50 mine, differing from them in its slightly larger dimensions and a larger explosive charge. Additionally, the MRUD lacks a clamp for attaching it to local objects and a sight on the upper part of the casing.

The waterproof casing is light green or olive-colored, with two holes for the detonator and three rough sighting lines on top, as well as a raised mesh pattern on the front panel of some early mines. Two removable metal legs are inserted into slots on the bottom to secure the mine during ground installation.

The mine has the shape of a curved parallelepiped. The convex side faces the enemy. The mine is placed only on a horizontal surface on its four extendable legs. Inside, along the convex edge, there are 650 pre-loaded lethal elements in the form of steel balls with a diameter of 5.5 mm. Upon detonation, the mine produces a stream of lethal elements that travel up to 50 m within a 60-degree sector. The stream reaches a height of up to 4 meters at maximum range.

At a range of up to 50 m from the mine, the fragment density is 1.5 fragments per square meter.

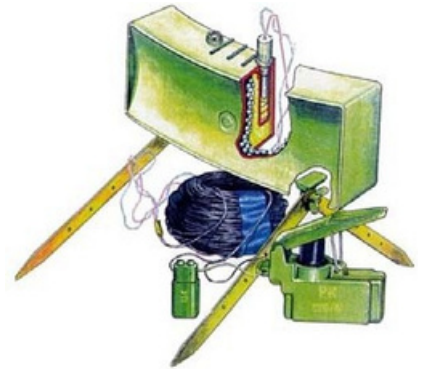

Technical Specifications

Mine Type.....	anti-personnel fragmentation mine with directed-effect guidance;
Casing	plastic;
Mine weight: total.....	2.2 kg;
Explosive (PE 64).....	900 g
Dimensions: Length.....	24.6 cm;
Height.....	16.5 cm;
Thickness.....	7.6 cm;
Number of ready-to-use projectiles.....	650 (5.5-mm-diameter pellets);
Operating temperature range	-30° to +30°;

The mine's operational life is unlimited.

The mine is not equipped with a self-destruct mechanism. It has no features designed to prevent removal or neutralization. However, nothing prevents such features from being placed inside the mine. Safe withdrawal of friendly troops to the rear must be at least 35 meters.

The MRUD kit comes complete with a handheld inductor, a circuit tester, and an EK-40-69 electric detonator. The mine can be detonated on command from a distance of up to 30 meters using a handheld inductor or another power source. The fuse chamber can also accommodate any Serbian M10 × 1 mm trap mines, including the UMP-1 and UMP-2 pull-type mines, as well as the UMNOP-1 multifunctional fuse.

It is also possible to use MVE-72 break-type target sensors and other sensors from the MVE series; traps can be placed inside the mine, including position-changing traps and joni.

The MRUD is supplied in a gray-green canvas shoulder bag, which also contains an ignition cable, a circuit tester, and a handheld inductor. Ten of these kits are packed in a solid wood crate.

Disarmament

Only the controlled version of the mine is subject to disposal. Upon detecting an exposed wire, ensure that both ends of the wire are secured before attempting to dispose of the mine. Approach the mine at a 90-degree angle (never from the front) to remain outside the blast radius. When following the tripwire's path, keep in mind that additional anti-personnel mines may have been laid along its entire length. It is all too easy to focus on following the tripwire and forget what might be hidden beneath it.

To neutralize the mine, cut the wires leading to the control panel. However, keep in mind that the presence of two sockets for electric detonators (fuses) allows the mine to be used simultaneously as both a remotely controlled and non-remotely controlled device, or to be detonated from either of the two control panels. In addition, a booby trap may be installed beneath the mine, as was the case in Yugoslavia. In Bosnia and Croatia, it was combined with the PMA-2 explosive anti-personnel mine by inserting one end of the detonating cord into the cavity of the MRUD detonator and attaching the other end of the detonating cord to the bottom of the PMA-2. When the explosive mine detonated, the MRUD also detonated.

Found by soldiers in the Kupyansk (Kharkiv Oblast) sector

**MPIM “HAILSTORM” mine
(Finland)**

In late January 2024, it was recorded for the first time on the border with the Belgorod Oblast



The deployment of new Finnish directional mines, which are part of the Multi-Purpose Infantry Munition System (MPIMS), a multi-purpose ammunition system for infantry.

The name of the “Hailstorm” series translates as “downpour” or “hailstorm.”

The mine is designed to engage personnel and unarmored military vehicles with preformed fragments. The mine features the “Hailstorm E” variant, which has increased fragment penetration capability due to the use of spherical tungsten fragments instead of steel ones.

The “HAILSTORM” mine was adopted by the Finnish Army under the designation VP2010.

Main Technical Characteristics of the Mine

Mine weight: total (without mounting).....	2.5 kg
Explosive (Forcit Defence plastic explosive) . .	
1.4 kg Number of ready-to-use fragments.....	924 pieces
Fragment diameter.....	5 mm
Effective range against personnel.....	100 m
Vehicles (2 mm steel plate).....	50/80 m
Initial fragment velocity.....	2,700 m/s
Fragment dispersion angle.....	60°
Height of the impact zone at a range of 50 m.....	2 m
Fragment density at a range of 50 m	5–6 pcs/sq m
Safe distance to the rear.....	15 m



The mine has a plastic casing. Standard mounting devices allow the mine to be secured to the ground and local objects (posts, trees). The mine is aimed visually through a removable tubular sight mounted on the top of the casing.

The mine has three types of fragmentation fillings: 1. Stainless steel fragments.
2-Tungsten fragments.
3-Combined fragments.

Depending on the fragmentation filling, the mine can be either anti-personnel or anti-vehicle.

The anti-vehicle version of these mines contains tungsten ball bearings that can penetrate up to 4 millimeters of rolled homogeneous armor at a distance of up to 80 meters.

The smaller version is called the Mini Hailstorm, or Mini MPIM.

**MPIM “MINI HAILSTORM” Mine
(Finland)**



The mine is housed in a plastic casing and is loaded with preformed spherical fragments made of steel or tungsten. It is deployed on the ground using three flexible legs and on vertical objects using a screw-type anchor. The upper surface of the casing features a sighting slot and protrusions indicating the boundaries of the kill zone.

Main Technical Characteristics of the Mine

Mine weight: total (without mounting).....	0.9 kg
Explosive (Forcic Defence plastic explosive) . .	
0.5 kg Mine dimensions.....	106 × 83 mm
Number of ready-to-use fragments.....	315 pcs.
Fragment diameter.....	5 mm
Effective range against personnel.....	50 m
Equipment (2 mm steel plate).....	30 m
Initial fragment velocity.....	2,400 m/s
Fragment dispersion angle.....	40°
Height of the impact zone at a range of 20 m.....	2 m
Fragmentation density at a range of 30 m.....	5 pcs/sq m
Safe distance to the rear.....	15 m



The MPIM Hailstorm mini mine comes with a tripod with flexible legs. It also includes a “G”-shaped support, one end of which is designed as a self-tapping screw. It can be easily screwed into wood by hand. The other end, when raised to the top position, holds the mine in a special socket. The top face features a sight for aiming the munition. There is a plate that snaps onto the rear surface of the mine. This allows engineering munitions to be quickly removed and deployed at pre-designated locations as needed.

The kits are carried either in tactical backpacks or in special pouches.

There is a wide variety of fuse types and target sensors, as well as installation options. There are a pair of standard sockets for fuses, equipped with threaded plugs and slots for a screwdriver. However, nothing prevents a sapper from carefully drilling a hole in any location and installing the fuse of their choice, or using whatever resources are available.

In addition to the main fuse, a secondary fuse (*a non-removal trap*) can also be installed. Select and check safe approaches (*there may be other mines, tripwires, or pressure-activated devices in the area*), and check for traps from the sides and below. Only then should you attempt to remove the mine or neutralize it on the spot by detonation.



Installation Options:

-With tension-type target sensors (“*tensionwires*”). A standard detonator (*functionally equivalent to the MUV serie*) is included in the kit for this purpose. The MUV can be adapted.



Initiation device, 30-meter Nonel tube (shock-wave tube, waveguide) with a manual initiation device. Similarly, the mine can be set with a tripwire, or the device can be replaced with another, such as a MUV with an MD-5m, an MVE-72 with an MD-5m, an EDP-r, etc.

-With an electronic detonator and a target break-off sensor. *A rather exotic but feasible solution, similar to one of the installation options for the OZM-72.*

-For a controlled detonation. Using standard wired lines and M57 detonators, as with the “Claymore,” or via a detonating cord.



There are countless options. The choice of method depends on the tactical objective. You can set up traps on enemy supply routes. Leave “surprises” in areas from which friendly forces have withdrawn. Or lay minefields in front of or around your own positions and initiate detonation manually as the enemy approaches.

Accordingly, these munitions must be detected by thinking in reverse—as the enemy would think—and carefully inspecting trees, bushes, and structures at various levels to identify now-familiar shapes.

Disarming these munitions and the types of fuses used. 1. The fuses can be of any type; this is a fragmentation munition that does not contain target sensors. When first discovered, it was equipped with a detonating cord of a new, previously unseen yellow color. 2. Defusing this mine is comparable to working with the MON-50 and “Claymore”; the “Livnya” has a plastic casing, so there may be many anti-recovery traps in place. By design, the mine has no standard anti-recovery mechanisms, but that does not mean they are not present.



The mine was first found on the border of the Belgorod Region; subsequently, it was also found on the border of the Bryansk Region and in the Kursk Region.

DM-41 Anti-Personnel Mine (Germany)

The German DM-41 anti-personnel pop-up high-explosive fragmentation mine is a limited-range



weapon. It is an improved version of the German DM-31 anti-personnel mine and is designed to mine terrain against enemy personnel.

The DM-41 has the same casing as the DM-31 but is equipped with a fuse that automatically deploys three tripwires (TPW).

The DM-41 mine consists of the warhead of the DM-31 mine and an electronic fuse. To arm the mine, one must press the button and rotate the safety lever on the top of the fuse from the “S” position to the “F” position. One minute later, three tension-type target sensors are ejected from the fuse’s sockets. The mine is deployed manually, as it lacks a mechanism for orienting itself vertically.

Main Technical Specifications:

Dimensions: diameter.....102 mm;
 height.....approximately
 210 mm
 Weight: total.....approx. 4.5–4.8 kg
 BB.....860 g
 Explosive type.....trinitrotoluene
 Detonation height.....1.2 meters.

Contact with any of the target sensors triggers the anti-personnel mine, which then functions identically to the DM-31.

When the TPW fuse is triggered, a charge at the bottom of the ground mine propels it upward to a height of 1.2 m, where the main charge detonates, ejecting a steel rod (CSR) outward. The expelling charge pushes the inner casing upward to a height of 1.2 m. At this moment, a wire attached to the outer casing—which is still in the ground—presses against a pin at the bottom of the inner casing and releases the locking balls from the spring-loaded firing pin (FP).

M16A1 Anti-Personnel Fragmentation Mine (U.S.)

The **M16 ARM** (Anti-personnel mine M16) is a circular-effect, pressure- and tension-activated anti-personnel pop-up fragmentation mine. It is analogous to the German World War II “Sprungmine” S.Mi.35 and the Soviet-Russian OZM-72.



It was developed in the early 1960s in the United States. It was adopted by the U.S. Army and Marine Corps in 1965. Three main variants of the mine were produced (until 1974): the M16, M16A1, and M16A2, which differed from one another in their internal design. Externally, it is possible to distinguish

only the M16A2, whose fuse is offset from the center. The mine was widely used by the U.S. in Vietnam



Main technical specifications of the M16 mine

		M16	M16A1	M16A2
Mine casing		Steel		
Mine weight: total	kg	3.74		2.84
Explosive (TNT)	kg	521	513	591
Intermediate detonator	g	69.3 Tetryl	32.8 5Tetr	11.18 Comp A
Ejection charge (black powder)	g	4.53		
Dimensions: diameter	cm	10.29		
Height (body)	cm	12.1		
Height (at the top of the fuse)	cm	19.9		
Target sensor types		pressure and tension		
Length of tension-type target sensor	m	up to 18 (one way)		
Actuation force of the tension-type target sensor	kg	1.4–6.8		
Actuation force of the target pressure sensor	kg	3.6–9.1		
Reduced diameter of the target pressure sensor	cm	4		
Minimum distance between adjacent mines	m	1.5–2		
Operating temperature range		-30 to +63°C		
Self-destruction/self-neutralization		No/No		
Radius of effect	m	Up to 27	Up to 30	
Scatter radius of individual fragments	m	200		
Time to reach combat position		instantly after the safety pin is removed from the fuze		
Main fuse		M605		
Operational duration		is unlimited		
Defusability		Not permitted		

The M16A1 mine consists of a sheet-metal casing (1) with two lids (2 and 3) rolled onto it. The upper lid has a threaded sleeve for screwing in the fuze. At the bottom of the casing lies a pouch (4) containing a charge of black powder (ejection charge). A projectile (5), which is a hollow cast iron casting, is inserted into the casing. The top of the projectile casing has a cast iron cover (6) with a threaded hole for screwing in the fuze. Three intermediate detonators (7) made of compressed TNT are inserted inside the casing.

Opposite them, three nipples—open at the bottom and equipped with powder retarders and detonator caps—are screwed into the base of the projectile casing. The remaining space inside the projectile is filled with explosive (8).

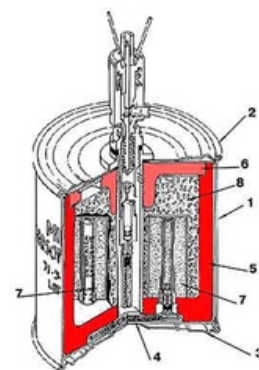

Principle of Operation

When the pressure sensor was pressed or the tension sleeve was activated, it moved downward, pushing



apart the safety ring at the base of the fuse, and the safety balls holding the striker fell into the resulting space. The striker struck the ignition cap, which transmitted the ignition force to the pyrotechnic delay element. While it was burning, the victim moved away from the mine; thereafter, the ignition force activated the black powder ejection charge (4.5 grams), and the pressure of the powder gases would tear off the mine's casing, propelling the mine body upward into the air while simultaneously transmitting the flame force to the pyrotechnic delayers of the two internal detonators. While they are burning, the mine rises to a height of 0.6–1.8 meters. Then the flame from one of the three nipples reaches the detonator cap

and detonates it. This triggers the intermediate detonator of both internal detonators, which in turn detonates the mine's main charge. Fragments of the projectile casing strike the targets.

Three fuses are installed in the mine to increase its reliability, although one is quite sufficient. The M16 mine is constructed in exactly the same way. Its differences from the M16A1 lie in purely design details. The M16A2 mine has a single nipple, allowing for a slightly larger explosive charge, though this does not significantly affect the mine's lethality. Later variants were equipped with pre-formed lethal elements (balls or rollers), which significantly increased its lethality.

The M605 fuse is a dual-action (combined—tension or pressure) ***fuse***. It can be used as a tension-action fuse, in which case a tension wire is attached to the ring-shaped trigger, and the fuse is triggered when an enemy soldier touches the wire. It can also be used as a pressure-action fuse. To trigger the press-action fuse, an axial pressure of 3.5 kg must be applied (by stepping on) at least one of the prongs protruding from the top of the fuse.

There have been reports (unverified) that new versions of the fuse cannot be disarmed. Cutting the tension wire or attempting to unscrew the fuse will cause it to detonate.

General Design of the M605 Fuse

- 1– main safety pin;
- 2– firing pin extraction ring;
- 3– rubber gasket;
- 4– ignition cap;
- 5– firing pins;
- 6– intermediate safety pin;
- 7– retaining ring;

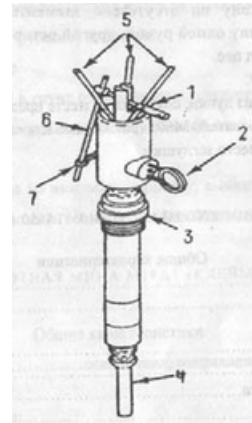

Removing and defusing the mine is not permitted under Russian regulations.

However, the U.S. Field Manual FM 20-32 does allow it. Perhaps if the mine was laid by a U.S. sapper, such “entertainment” is permissible, since the U.S. sappers’ arsenal does not include booby traps similar to the Soviet MS-3, MS-4, ML-7, and ML-8.

The U.S. maintains large stockpiles of M16A2 mines for use in any conflict.

Deliveries of this mine to the Ukrainian armed forces are expected.

M67 (M72) Anti-Personnel Mine (U.S.)

The M67 and M72 anti-personnel mines are anti-personnel cluster fragmentation mines with circular effect; they are tension-activated pop-up mines deployed using remote-mining systems.



The M67 and M72 anti-personnel mines were adopted by the U.S. Army in 1975; in essence, these mines are analogous to the Soviet POM-2 “Otek” anti-personnel mine and the Russian POM-2R.

The M67 and M72 anti-tank mines are designed to neutralize enemy personnel.

Enemy soldiers are injured by shrapnel when the explosive element (projectile) detonates at a height of approximately 0.15–2.5 meters; the projectile is ejected from the mine when a soldier trips one of the seven tripwires.

Main Technical Characteristics

Name	Parameters	
Mine Design	M67	M72
Casing Material	Metal or plastic	
Dimensions: Segment radius	55 mm	
Height	66 mm	
Weight: mines	540 g	
Explosive (Composition A5)	21 g	
Projectiles	Fragments of the explosive element's casing	
Fuse	Built-in, as part of the mine's design	
Fuse type	Electronic contact	
Target sensor type	Tension-type	
Length of the tension-type target sensor	6 m	
Actuation force	0.45 kgf	
Continuous detection radius	up to 4–7 m	
Radius of individual shrapnel fragments	up to 10 m	
Number of mines in the non-retrievable version	20%	
Armed after release	45–120 seconds	
Operational duration (self-neutralization)	14 days	
Retrievability/neutralizability	No/No	
Self-destruction/self-neutralization	Yes/Yes	
Operational life	4 (self-destruction)	48 (self-destruction)
Color	Olive green or dirty yellow	

The M67 and M72 anti-personnel mines are submunitions of the Area Denial Artillery Munition (ADAM) remote-mining system, which is part of the Family of scatterable mines (FASCAM).



The M731 cluster munition contains 36 M67 mines arranged in nine rows (four mines per row), each with a 4-hour delay before self-destruction.

The M692 shell contains 36 M72 mines arranged in nine rows (

row) with a self-destruction delay of 48 hours (2 days). At the manufacturing plant, the mines are packed into the casings of M692 or M731 shells of the M483 artillery round, equipped with an M577 remote-action mechanical fuse. The fuses are automatically armed 45 seconds to 2 minutes after ejection from the shell.



The M692 and M731 shells are fired from the 155-mm M109A1 self-propelled artillery system and the 155-mm M198 towed howitzer.

The delivery range depends on the firing range of the specific artillery system and can average up to 18 (M109A1 howitzer) – 24 km (M198 howitzer). The dispersion of mines across the terrain from a single shell is up to 600 meters from the aiming point.



After the mine is ejected from the artillery shell casing, the plate that short-circuits the combat circuit is destroyed, and a glass ampoule containing electrolyte is crushed, saturating and activating the battery. The battery activates an electronic delay mechanism; after 60 seconds, the electric detonator connects to the mine's electronic circuit.

Simultaneously, seven tension-activated target sensors (nylon tripwires) are scattered in all directions within a radius of up to 6 m by springs; 3–4 of these are guaranteed to uncoil to their full length depending on the mine's position. After another 10 seconds, the mine fully transitions to its combat-ready state.

The electronic contact fuse, which is an integral part of the mine's design, is triggered by a change in the mine's position that occurs when an enemy soldier snags one of the wires.

The mine is triggered by tension on the tripwire or a change in the position of the mine body. In this case, an electrical impulse is first transmitted to the electric detonator, igniting the liquid expelling charge, which—under the influence of gravity and regardless of the mine's position—is always located beneath the ejected warhead. The expelling charge destroys the mine casing and propels the spherical warhead upward, simultaneously igniting its pyrotechnic delay element. After the delay element burns out at a height of 0.15–2.5 m, the detonator cap is triggered, initiating the explosive charge,



Warhead

which shatters the casing of the warhead into fragments.

After the combat service life expires, the mines self-destruct.

The mine is non-deactivatable and non-retrievable.

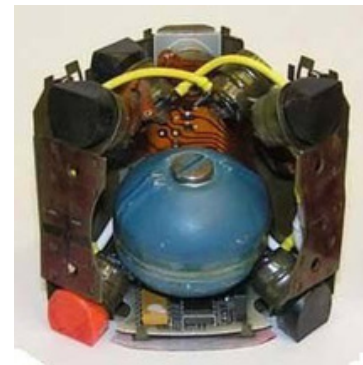
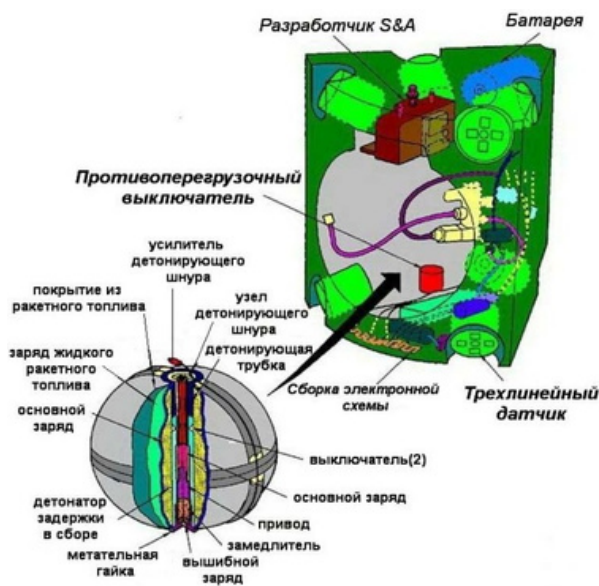

The mines are olive green or dirty yellow in color.

A significant drawback of the mine is that it must not land on hard surfaces (asphalt, concrete), as this may result in the destruction of the mine's casing or the failure of its mechanisms.

One in five mines is equipped with a non-retrievable mechanism. It is prohibited to defuse these mines.

In December 2024, these mines were discovered by our Black Sea Fleet Marine Corps sappers during a special military operation

M86 Anti-Personnel Mine (U.S.)

The M86 anti-personnel mine is a circular-effect anti-personnel cluster fragmentation mine with a tension-triggered ejection mechanism, designed for rapid mine laying to neutralize enemy personnel.



It was developed based on the M67 anti-personnel mine for U.S. special operations forces as an ordnance that allows for the rapid mining of retreat routes for reconnaissance units being pursued by the enemy.

The M86 mine differs from the M67 mine in that it features a manual setting mechanism (a firing bracket with a safety pin and a remote arming mechanism).

Main Technical Specifications of the M86 Mine

Casing	Metal.
Weight: total	544.3 g
BB (A5: 91% hexogen and 9% plasticizer) . . .	21 g.
Size: segment radius length	7.4
cm.	
Segment height	8.14 cm
Segment angle	72 degrees
Target sensor length (one way)	6 m.
Number of tension-type target sensors	7 pcs. (3–4 operational) Fuse
.....	Built-in, part of the structure
Sensitivity	454 g
Radius of effect	up to 4
m Scatter radius of individual fragments	up to
10 m	
Burst altitude of the fragmentation element	0.15–2.5 m
Self-destruction time	4 h
Delayed detonation time	60–70 sec.

After removing the safety pin and the firing clip, the plate that short-circuits the firing circuit breaks, and the glass ampoule containing the electrolyte is crushed, saturating and activating the rechargeable battery. The rest of the operating principle is similar to that of the M67 mine

The mine is deployed only manually in the following order:



- a) while holding the mine by its body,
remove the safety pin;
- b) Pull the firing clip ring upward to remove it;



- c) throw (place) the mine at the desired installation location;
- d) retreat to a safe distance.

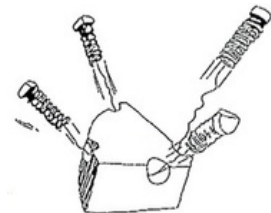

The M86 mine is non-retrievable; self-destruction occurs approximately 4 hours or after the power source voltage drops below the set level.

Disarming is prohibited.

K-2 Anti-Personnel Mine (Ukraine)

An improvised mine, with some potential for small-scale production, inspired by the Soviet POM-2. It is not uncommon in combat zones and near-rear areas, and therefore deserves attention.



General designation: **POM-S**. Here, “S” stands for “homemade” (*samodelna in Ukrainian*). However, it is found with various markings. There is no uniform standard. The marking “K-2” is often encountered, named after the group who invented this mine.

Some bear the designation of the brigades using a specific batch, for example, “110th Mechanized Brigade.” We’ve also encountered the name “Bandera K-2.”

Updated versions are also being produced.



A drop munition that operates on a principle similar to the POM-2 mine.

Mining with the POM-S is intended exclusively for use with small drones. It is a drop munition. However, it does not operate on the “landed—immediately exploded” principle, but rather “landed—activated.”

Main Technical Characteristics

- Mine weight: total.....approximately 550 g.
- fragmentation jacket.....about 230 g
- Explosive weight (PVV-7, C4, etc.) approximately 72-75 g
- Dimensions: Length.....255 mm.
- Inner diameter.....32 mm.
- Thickness of the tube or spring.....4 mm.
- Maximum width (*stabilizer wing span*): 155 mm.



- Length of DC threads.....5 to 10 m.
 - Number of target sensors.....usually 4.
 - Force required on a target sensor to trigger the mine approximately 3–5 kg.
 - Sensor Material.....fishing line, braided Kevlar line used for spinning and feeder fishing. It comes in dark green, black, and various shades of gray, ranging from dark to almost white (*for winter*).
 - Detonator.....EDP.
 - Power source 1 AAA battery.
- Specifications are average and vary from version to version; different enemy units have their own specifications.



General Mine Design

–A **pin** protruding from the front, which is designed to drive the mine into the ground and secure it in place. The pin is threaded. It has washers that can be slid up or down to adjust the depth of penetration into the ground (*depending on whether the ground is muddy or not*).



– **Warhead.** A section of steel pipe or a sturdy homemade spring (*not very springy 4-mm-thick steel wire 4 mm thick, wound around 32 mm-thick rebar*). It has notches cut with an angle grinder about 2–2.5 mm deep, forming semi-finished striking elements. Inside the pipe or spring is an explosive. The fragmentation jacket is separated from the main explosive charge by a plastic pipe with a wall thickness of 1.5 mm.





The main charge, consisting of PVV-7, is placed inside the plastic tube; inside the charge is an EDP connected to the electrical circuit via a connector (surprisingly, the wires are twisted together and enclosed in a heat-shrink tube).

The parts of the casing and the fragmentation jacket are joined with hot glue.

–**Electro-detonator.** Wires. AAA battery (*mini-finger-sized*).

–**Target sensor assembly.** Target sensors—5–10 m lengths of fishing line. In early experiments, they were 10 m long. Later, we realized this and started using 5–5.7 m lengths. Weights, which are actually made of plastic. Springs.

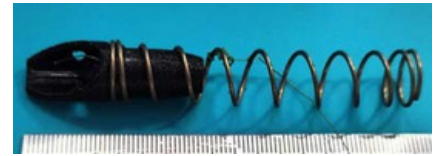

A switch consisting of a springy steel wire positioned along the longitudinal axis. The ends of the fishing line segments (target sensors) are attached to it. A steel washer surrounds the wire. Due to the wire's elasticity, it can touch the washer if any of the fishing line segments is pulled. This closes the detonator circuit, causing an explosion.

A tail section with fins. It serves to stabilize the device during descent. In addition, the ring on which the fins are mounted acts as a stopper, covering the openings and preventing premature ejection caused by the springs of the target sensors (*strings with weights*



at the ends).

The plastic parts were 3D-printed. Thanks to this technology, it was possible to manufacture fairly complex components even without a full-scale industrial infrastructure. The parts are joined with hot glue and, in some places, electrical tape. Yes, we had to do without pyrotechnic retarders, pyrotechnic charges, and other components typical of the POM-2. Attempting to circumvent these aspects comes at a cost in terms of reliability and the rate of intended detonations.

Use of the POM-S Mine

The mines are stored with the explosive circuit open (*first safety*). Before the drone takes off with the munition, the wires are twisted together. As long as the tail fin is in place, it also serves as an additional safety mechanism, preventing the closing wire from moving. Before takeoff, the pin holding the tail section in place (*the second safety mechanism*) is removed.

After being dropped, the mine stabilizes in flight with its tail fin in a vertical position; upon impact with the ground, it burrows into it (if it strikes a solid object, the head section with the threaded pin may break off from the main body). The body is already stationary, while the loosely fitted tail section, due to inertia, shifts down slightly further. This opens the openings in the target sensor block. The springs straighten out, and the weights (a plastic part with a nut) attached to Kevlar (fishing) lines fly out to the sides, reaching 5–5.5 m. This results in four tension-activated target sensors spread out in four directions. It may not form a perfect cross, but it's close.



When the lines are pulled with a force of about 3–5 kg, the needle (to which one contact of the electrical circuit is attached) touches a metal washer installed in the base of the warhead (to which the other contact of the circuit is attached), thereby closing the electrical circuit that supplies current to the electric detonator, which in turn causes an explosion (if the battery is still working).

It's certainly good news for our side that these homemade devices work very poorly. There are no statistics, but at a glance, there's no way even 50% of them function correctly. Even 25–30% is questionable...

Weak points:

- The ground may be too hard. The pin may not penetrate, and often does not.
- The munition lands face-down faster than the tail section can slide downward. The target sensors aren't ejected, and the mine doesn't arm properly.
- If the mine lands flat, and even if the target sensors deploy normally, some of them will lie coaxial with or at a slight angle to the mine's longitudinal axis. No matter how much you tug on it, the detonator won't fire. Only if the angle between the string and the detonator wire is close to a right angle will detonation be highly likely.

- Upon impact, the mine may simply break into pieces, which also happens quite often.
- If left sitting for a long time, especially in the cold, the battery will die, and the munition will no longer function. But of course, you shouldn't test this... Treat it as if it were live.
- Even if the pin is inserted, the friction between the tail ring and the casing is often greater than expected. The tail simply doesn't slide down due to inertia, and the target sensors don't fire. This is a very common scenario.



The sensors were fired, but like this section didn't shift quite a bit buried itself in the ground.



Debris from a POM-S mine. The self-destruction unit is visible. The casing has shifted. The target sensors did not deploy.



The mine landed flat. The tail section themselves: Threads, springs, weights. The tail section

Defusing

Primary method: on-site detonation using an external charge with an ignition tube. Of course, you can cut the circuit wires with wire cutters (one at a time!). But this only works on mines that have been partially destroyed by a fall, when the wires are visible. This is not an uncommon occurrence.

The enemy isn't standing still, and it's possible that they're using similar mines equipped with mechanisms that make them impossible to remove or defuse, as well as various electronic target sensors (proximity, volume, vibration, tilt, and magnetic). That's why an over-the-top charge is more reliable.

As expected, in the summer of 2025, industrially manufactured versions of this mine appeared. The likelihood that the mine now additionally features its own "jonik" (an electronic anti-disarming element) is increasing.

Consequently, we should expect these mines to appear in all sectors of the front line.



This mine is found in all combat zones (primarily where there are national battalions).

P.S.

It seems the enemy has decided to modernize the K-2 mine; this time, they've gone all out and used the OZM-72 mine as the warhead. The fuse is, as usual, 3D-printed; instead of 4 detonating cords, they used 6 (the exact length of the detonating cords is unknown, but with the OZM mine, it's at least 10–15 m).



Instead of springs to eject the spools with the wire, they've now used powder charges and electric igniters (just like on the POM-2). The main target sensor appears to remain unchanged (a disc-and-needle switch). When any of the threads is pulled taut, the electrical circuit closes, triggering the mine's standard detonation. It is not yet clear whether an additional switch or the initiation circuit board is responsible for firing the detonators.



The initiation of the OZM-72 itself is apparently managed by the housing from the MUV and EDP. A circuit board and a microswitch have appeared; remote arming may have been added.

However, the device will be modernized by the enemy and deployed throughout the entire front line.

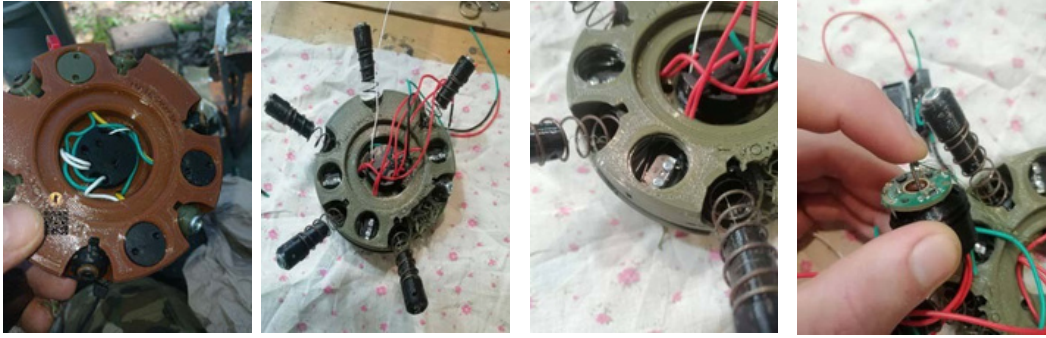

An important note: the magnetometer may be used as a non-removability feature, but it can also be triggered by the approach of metal (a change in the magnetic field); therefore, unlike the makeshift POM-2, moving it from its position is life-threatening! Once it's armed, it's best to destroy it with an over-the-top charge or a hydraulic demolition device; naturally, place the charge using a long pole from the SIBZ, and if possible, from a drone.



Further Improvements

The OZM-72, prepared by the enemy for remote deployment from heavy



multirotor UAVs.

The "Kaplya" target sensor, two safety mechanisms (one is a dielectric fuse that breaks the battery contact), a mechanism for remote arming in 10 minutes, triggered by a person approaching within a distance of 10–15 m; the target sensor is volumetric, based on the Doppler effect.



How to counter it? Drop charges from drones nearby, fire from a distance of more than 30 m, use the ZRP-2 and other demining charges.

But the biggest problem is detection, since it's nearly impossible to spot one of these in the grass next to a trail while walking along the trail itself, and few have the capability to conduct IR reconnaissance with drones on such a large scale—it's not fast, and sappers still have to follow up on foot anyway.



Be vigilant and careful, as the enemy never sleeps and is constantly improving!

Just think how much further they'll improve the camouflage of such mines, as was the case with the makeshift PTM-3...

The enemy continues to improve the deployment of OZM-72s from drones. This time, they are an improvement to the target sensor ejection mechanism.

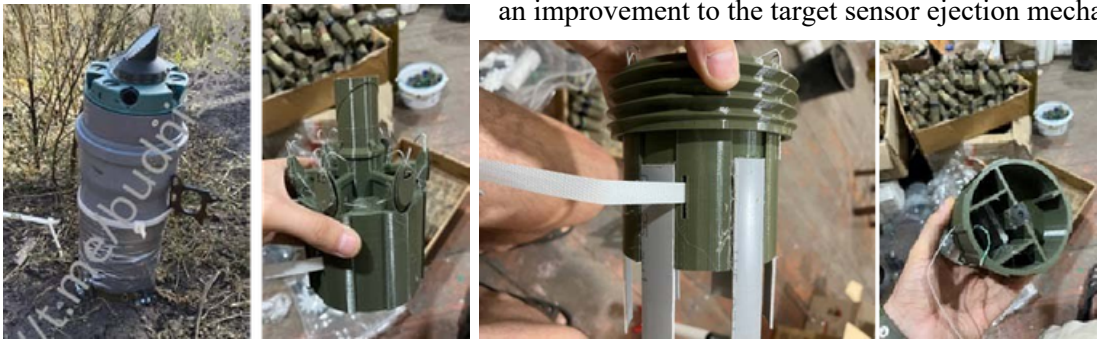

Another version of the enemy's makeshift POM-2: the target sensor unit has been updated. It differs from older versions—the K-2 and “Bandera”—in that it has a switch on top and a different shape. I assume the switch is used to set the mine to combat mode or to set it to a long-range trigger before the carrier takes off.

The casing resembles the expelling charges from various PG-7 grenades previously found by colleagues, complete with an adapter for attaching the target sensor unit.



Continuing to refine its bottom-mounted munitions, the enemy has created yet another modification.

This time, it is the OZM-72, remotely controlled via a radio channel; the enemy drops these from UAVs near supply routes and other locations where personnel are present, which they can monitor, and the detonation command is issued when personnel approach the mine to maximize casualties.

UPM-O Anti-Personnel Mine (Ukraine)

The UPM-O anti-personnel mine has recently entered service; it is a sort of “child of war”—as simple as possible, cheap to produce, and... not particularly relevant in modern combat conditions.



The mine is classified as an anti-personnel fragmentation barrier mine with circular effect. The body consists of a plastic casing and a stack of partially notched steel discs designed to produce fragments.

A range of simplified mine fuses



(MUV) with MD-5m or MD-2 fuses, a tension-type target sensor, and the mine is equipped with a plastic stake for installation in the ground.

The mine is deployed manually. A 75-gram “drilling” TNT block is recommended as the explosive charge.

Essentially, this is a POMZ-2 mine, version 2.0. With a little ingenuity and the necessary equipment, this mine can be used with various detonators,

including non-contact ones. It can also be adapted for deployment via a UAV.

“Volchek” (“Dziga”) Anti-Personnel Explosive Device (Ukraine)

The “Volchek” (“Dziga”) anti-personnel explosive device is a modern coded electronic munition with a Ukrainian-developed control processor.

It is designed to engage personnel, unarmored vehicles, robotic systems, and UAVs.

This device is designed to be compatible with various modern combat systems.

The munition features a universal platform that allows it to be deployed both as a hand-held device and via robotic systems and unmanned aerial vehicles.

Structurally, the “Volchek” consists of a warhead and an electronic initiation unit. The casing is made of impact-resistant polyamide using injection molding. The striking elements consist of a mixture of steel rollers and metal-ceramic cubes. This composition provides a continuous area of destruction of 7 meters.



Main Technical Characteristics

Mine weight: total.....	1.45 kg
Explosive (compressed TNT).....	250 g
Intermediate charge.....	12 g
Dimensions: diameter.....	132 mm
Height.....	76 mm
Projectiles: total number.....	780 g
Steel rollers: quantity.....	400 pcs.
Dimensions	L = 6 mm D = 6 mm
Weight.....	1.16 g
Metal-ceramic cubes: quantity.....	500 pcs.
Size.....	5 × 5 × 5 mm
Weight.....	0.6 g
Guaranteed kill radius.....	7 m
Steel sheet penetration depth.....	up to 2 mm

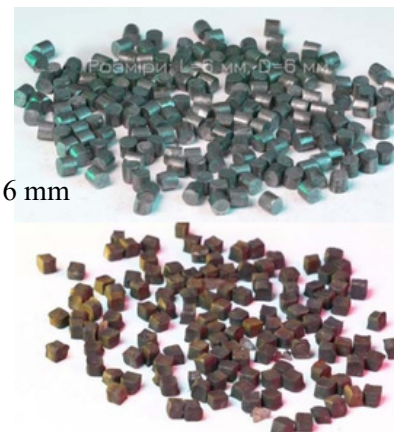

General design:

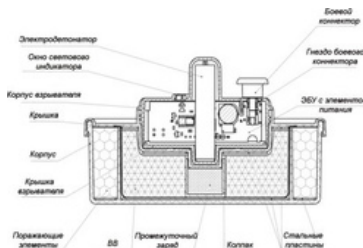
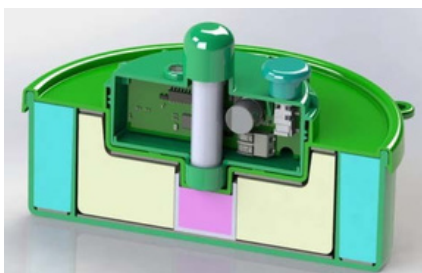

The electronic unit has 3 mechanical fuses and several electronic safety circuits: a safety timer, a safety detector safety detector.

The control unit is programmable for specific usage scenarios, allowing the activation logic to be adapted to changes in spatial position (gyroscope data), impact detection (accelerometer), or an external control signal.



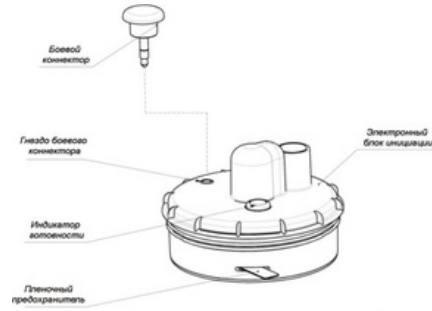

When deployed manually, the mine can be set up either as a conventional high-explosive mine or as a fragmentation mine with circular blast effect (more effective).

When deployed as a fragmentation mine, it is set with 4. It is equipped with target sensors (tripwires) up to 7 meters long. A special attachment with 4 channels for triggering the tripwires is used for this purpose. It is recommended to place one mine at least 12 meters away from the next.



The mine is most effective in confined spaces (urban areas). When detonated at a distance of 1 meter, the target can be struck by up to 75 fragments.



The munition can also be used with a robotic mine-laying system (such as the “Yastreb”) adapted for the automatic deployment of minefields and controlled remotely.

The “Volchek” munition can be effectively used by unmanned aerial vehicles (UAVs) both for dropping and as ammunition for FPV drones. It can be used in fully autonomous mode. In this case, the impact must be at least 4G, or the munition must be initiated by the drone’s control system (remote detonation).

In addition, a remote mining system using UAVs has been developed for the “Volchek,” consisting of a parachute system that detaches upon landing, a guide pin with a cartridge, and a spring-loaded target sensor ejection system.



59
M-42 Submunition
(U.S.)

In 1973, the U.S. Army adopted the M483A1 155-mm cluster munition, which subsequently became standard issue for NATO armies. It consists of a steel casing, a propellant belt, and a detachable base. The shell's chamber contains 88 submunitions (64 M-42 submunitions are located in the front section, and 24 M-46 submunitions in the rear section).



Both variants are identical in design and contain 30.5 g of A5-type explosive; however, the walls of the M42 submunitions are thinner than those of the M46 and feature internal grooves to enhance the fragmentation effect. The projectile's nose section features a hole for screwing in a cup containing the detonator. A metal diaphragm is located between the detonator and the warhead.

M42 High-Explosive Fragmentation Warhead

- 1 – steel casing with internal grooves;
- 2 – A5 explosive charge; 3 – conical shaped-charge funnel;
- 4 – contact mechanical fuse;
- 5 – ribbon stabilizer; 6 – propellant charge;
- 7 – propellant spring; 8 – firing pin; 9 – solid sleeve;
- 10 – detonator; 11 – lead plug

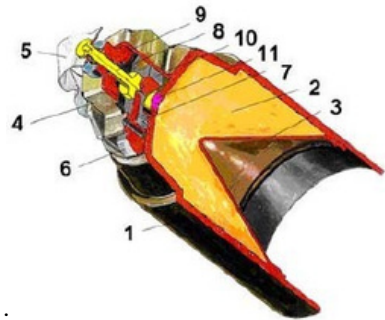

The components are ejected through the bottom of the projectile's casing

of the projectile via a diaphragm and a fuze triggered by an M577 remote detonation tube at an altitude of approximately 350 m. In flight, the KOBE is stabilized by a 19-mm-wide ribbon loop attached to the striker of the BE fuze.



- Взрыватель
- Вышибной заряд
- Крышка
- Корпус снаряда
- Суббоеприпасы
- Ведущий люсок
- Переходник
- Обтуратор
- Газогенератор
- Корпус газогенератора

The firing range is up to 17 km. Later, some of these shells were filled with M43 fragmentation submunitions. Subsequently, the M483/A1 shell was replaced by the M864 shell, which had an increased firing range (achieved via a base gas generator) of up to 28 km (48 M42 and 24 M46), which was in turn replaced by the M982 projectile (64 M85—improved versions of the M42/46). Submunitions with a cumulative charge can penetrate up to 7 cm of homogeneous steel armor .

The shell detonates in the air at an altitude of about 200 m, scattering submunitions over a diameter of up to 100 m. If the cassette itself fails to open, it can function as a conventional high-explosive shell. However, neither the M42 nor the M46 is equipped with self-destruction mechanisms. And given that M864 shells and their submunitions have been in U.S. military stockpiles since the 1980s, it is worth noting data from the Pentagon's Inspector General, published in the American media: between 5 and 14% of them may fail to detonate at all.



How It Works

Upon firing, the propellant gases ignite the ignition charge, after which the inhibited HTPB burns relatively slowly for approximately 22 seconds, filling the vacuum created by the aerodynamic airflow behind the shell casing. This reduces drag behind the projectile, thereby increasing its range.

During operation, the M577A1 delayed-action fuze activates at a selected point along the projectile's flight path and initiates the booster charge located at the base of the fuze's housing. This, in turn, initiates the ejection charge, consisting of 90.7 g of M10 propellant. This generates significant internal pressure, which, acting through the pressure plate and the submunition assembly, tears the adapter from the gas generator housing and propels it backward along the projectile's trajectory, after which the submunitions are ejected from the projectile's body. Centrifugal forces disperse the submunitions radially from the projectile's flight path.

The submunitions are mechanically armed by rotation after being ejected from the projectile. During flight, they stabilize and orient themselves for impact by unfurling a nylon ribbon, which also generates the rotation needed to arm the fuze.

The submunitions detonate upon impact when the built-in M337A1 sliding fuze is triggered, which mechanically initiates the M55 detonator.

In short, the pros and cons for the Ukrainian Armed Forces:

- + There are plenty of them; they were awaiting disposal, so this is a win for the U.S.—we just need to steer the media narrative in the right direction;
- + They are effective against exposed infantry (*and significantly more effective than conventional high-explosive rounds*).
- They are less versatile, so their effectiveness when shelling positions is much lower than that of conventional high-explosive shells;
- A high percentage of duds—14% according to various sources—even though they were stored properly. We can expect up to 25%, which means there will be a lot of “war debris.”
- They are ineffective in urban areas.

Used during combat operations across the entire theater of operations.

61
M-74 Submunition
(U.S.)

The M74 submunition consists of a steel casing filled with explosive material.



It is worth noting that the “filling” of ATACMS varies. These are mainly round submunitions. And while it was clear from the scattered submunitions during the shelling of LPR territory that they were explosive devices, those used in Crimea do not resemble submunitions and can easily be mistaken for a stone ball.

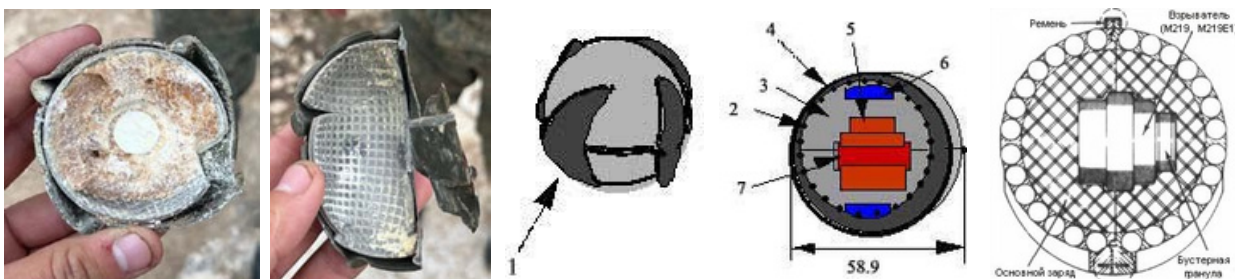

Designations:

1. A special technological groove designed to produce a large number of fragments upon detonation;
2. A tungsten inner wall with a honeycomb structure, allowing for the production of a specific number of fragments;
3. Explosive charge;
4. Steel casing;
5. Initiating powder charge;
6. Ignition cartridge;
7. M219A2 fuse;

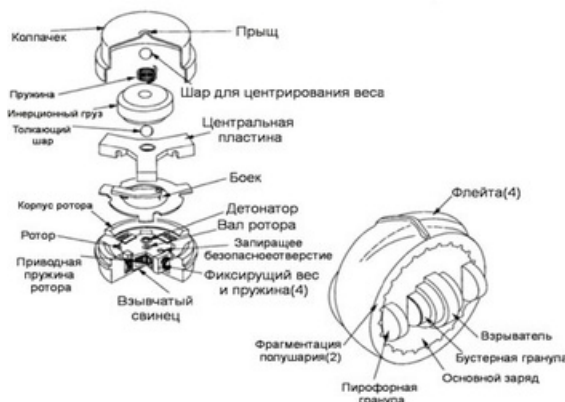

Общее устройство взрывателя M219A2

The M74, which resembles a baseball, is a vicious weapon. It is equipped with a high-explosive fragmentation charge inside this irregular sphere.

Its asymmetrical design causes the warhead to spin as it is dropped. As soon as the rotational speed reaches 2,400 revolutions per minute, its fuze is triggered. Hundreds of M74s falling almost simultaneously create a cloud of shrapnel that blankets the ground. The weapon is considered highly effective against personnel and lightly armored targets.

Technical Specifications:

- Weight.....590 g;
- Explosive weight (Composition B)..... 127 grams;
- Buzzer charge (hexogen).....1.4 grams;
- Radius of effect.....15 meters
- Additional ignition elements—two pyrophoric granules, 5 grams each. M219 fuse (M219E1—the difference lies in the addition of a fluorocarbon-based lubricant

phenolic resin) to the rotor; rotary delay mechanism; inertia-action fuse.

Projectile elements—tungsten (nickel-alloyed) hemispheres housed in steel outer casings.

Painted olive-gray with no markings.



When the rocket's delayed-action electronic fuze is triggered, the shaped-charge warheads mounted on the rocket's skin and bulkheads detonate. This, in turn, tears off the skin. Under the action of centrifugal force and airflow, the submunitions are dispersed over the target area. The grenades are armed by rotation (approximately 2,400 revolutions per minute are required). Upon impact, detonation occurs, shattering the tungsten hemispheres and the casing to form high-velocity fragments; simultaneously, the capsules containing the pyrophoric composition ignite.

There is no external indication of arming; therefore, it is safe only when inside an undamaged warhead. If it is outside the warhead, it is considered live!

According to U.S. standards, it is permissible to carefully lift ready-to-fire M74s one at a time and transport them to a disposal site in separate boxes or crates placed on top of a layer of sand, sawdust, or other cushioning material.

The Ukrainian Armed Forces used ATACMS missiles with M-74 submunitions against targets in the LPR (Luhansk, Rovenky, Krasnodon), the DPR (Berdyansk), and Crimea

M-77 Submunition (U.S.)

The M77 is a DPICM-type submunition used in multiple launch rocket systems (MLRS). The M77 was developed based on the M483A1, which was designed for so-called “high-explosive” artillery shells of 155 mm and 8-inch calibers.

Main Specifications:

Mine type.....High-explosive fragmentation
 CasingMetal
 Weight: total.....292 g
 Explosive (TNT, hexogen) . .
 33 g Dimensions: diameter.....3.8
 cm
 Height.....8.1 cm
 Fuse type.....Electric
 Installation method.....remote



The A-improved standard dual-purpose (DPICM) munition is an artillery

Суббоеприпас М 77



or rocket et a “ground-to-ground” warhead designed to detonate submunitions at an optimal altitude and distance from the intended target to provide dense coverage. In submunitions, both penetrators formed by explosives for anti-tank protection and fragmentation submunitions for anti-infantry operations are used. Some submunitions may be designed for rapid response or to

limit the mobility (mines). This type of munition

"air-to-surface" class is better known as a cluster bomb. They are banned by some countries in accordance with the Convention on Cluster Munitions.

As a rule, they are used in cassette munitions for multiple launch rocket systems. *The M77 is a dual-purpose submunition: it is effective against both infantry and armored vehicles.*

During flight, the white ribbon vibrates due to air resistance, which cocks the submunition. For this reason, it is best not to “fiddle with” an uncocked submunition, as this can cause the ribbon to move, which in turn activates the mechanism.

The M77 is a cumulative/cumulative-fragmentation submunition cluster munition. Seventy-two submunitions are dispersed from a multiple launch rocket system (MLRS) cassette, falling at intervals of approximately 3 meters.

It is roughly the size of a light bulb socket, making it difficult to spot among debris and in ruined terrain.

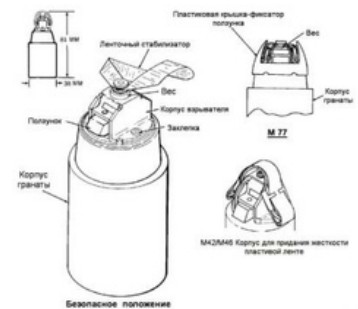

HIMARS can use the following munitions:

M26 — the base version, containing 644 M77 submunitions.

Range: 5–32 km.

M26A2 ER — an “interim” long-range version developed due to delays in the production of M85 submunitions.

It was equipped with 518 M77 submunitions.

Range: 5–45 km.



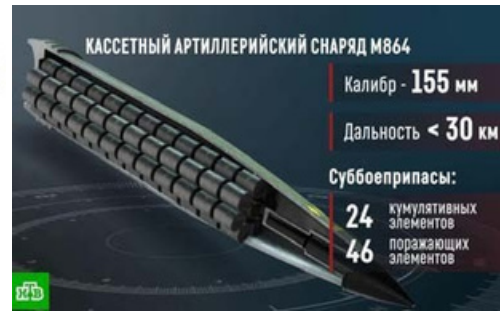

Disarmament:

According to observations, every 4th or 5th cluster does not detonate or detonates only partially. As a result, large quantities remain lying in the most unexpected places or even hanging from tree branches due to the stabilizer tape.

Contrary to a widespread misconception, this is not a dangerous device and can certainly be defused. However, as the design of the fuze shows, the propellant charge with the detonator cap (the part of the fuze protruding to the side) can be pushed back into its original “SAFE” position with a careful, gentle press.

To defuse an unexploded sub-munition, take the following steps:

1. *Locate and inspect the surrounding area for any other similar items.*



2. *Carefully lift it by the strap or casing without shaking it—back into the until it stops*



3. *Push the object protruding to the side—the propellant charge with the detonator cap*



4. *Try to screw the firing pin back in tape and the stabilizing tape, or simply slightly apply the tape to the casing*



5. *Begin wrapping it with electrical securing the motor and the tape*

turns

6. *Make sure the motor doesn't pop back out.*

This sub-munition is used by Ukrainian fascists during the special military operation in Ukraine with both MLRS systems and 155-mm artillery pieces

Submunitions M-85; M-87 (U.S., Israel)

The M-85 submunition belongs to a category of submunitions delivered by various types of artillery munitions, including shells, mortar rounds, and rockets, and is designated by the acronym DPICM: **Dual Purpose Improved Conventional Munitions**.



The dual purpose of this submunition lies in the fact that the warhead features a cumulative cavity capable of penetrating armor and an outer shell designed to create fragments that strike infantry.

Most DPICMs are based on the design of the American M42 submunition, with the M46 and M77 also being modifications of it.

DPICMs are compact munitions that provide sufficient lethality and armor-penetration capability. DPICM submunitions weigh about 300 grams, have a diameter of about 40 mm, and contain 20–50 grams of high-explosive. Their shape is determined by the geometry

of the shaped-charge warhead and the need for compact packaging within the parent cluster munition.

Tactical and Technical Specifications of the M85

- Submunition type: DPICM (enhanced dual-purpose conventional munitions)
- Delivery method.....artillery shell, mortar round, multiple launch rocket system (MLRS) rocket
- Weight: munition.....292 g
Explosive (hexogen).....44 gr.
- Number per M396 shell.....49
- Dispersion area from the M396.....an ellipse with a radius of about 100 m (3 ha)
- Number of fragments.....approximately 1,200
- Casing composition.....13 fragmented steel rings, 3 mm thick,
a 2-mm-thick aluminum liner
- M85 failure probability stated: less than 1%; actual: more than 10%

M-85 submunitions and their equivalents are stacked on top of one another, with the fuze of one submunition placed inside the cavity of the cumulative recess of another.

While most DPICMs have only an impact fuze, the new generation of DPICMs includes a **self-destruct** mechanism (SD), which is designed to destroy the submunition's charge if the main impact fuze fails to detonate. Most SD mechanisms consist of a pyrotechnic delay element, but electronic SD mechanisms also exist.

The M85 with an SD function was developed to eliminate the shortcomings that led to frequent failures encountered with American DPICMs (M42, M46, M77). According to its stated specifications, this submunition is capable of penetrating armor up to 105 mm thick with a cumulative jet, while the fragmentation of the casing upon detonation produces approximately 1,200 fragments.

The M85 fragmentation mechanism is designed to utilize the high rotational speed imparted to artillery shells. Consequently, in its original form, it cannot be launched from mortar rounds or rockets, which have much lower rotational speeds than artillery shells. However, IMI (Israel Military Industries) has adapted the M85 for various mortar rounds and artillery rocket systems, such as the MLRS, LAR-160, and MAR-350. One of these adapted versions is designated the M87.



Arrival of submunitions from a 155 mm M864 cluster munition

The M85 munition is designed to operate as follows:

The warhead's fuze is set to an appropriate time delay, calculated based on factors such as range and the relative



altitudes of the launch point and the target. Once the shell has been ignited and the delay has elapsed, the fuze activates the internal propellant charge; this acts on a “push plate,” which moves the stacked submunitions toward the rear of the shell. The base of the projectile is ejected, allowing the projectile elements to exit the rear of the casing at a velocity of approximately 70 m/s.

Because the projectile rotates rapidly, most of the warheads are ejected radially outward as they leave the casing. The exception is the central charge, which disperses in the turbulent airflow behind the projectile. Each warhead also maintains a high clockwise rotation speed, different from that of the original projectile.

Inside the fuze is a spring-loaded transverse locking pin made of a solid shell.

As the slide moves, the hammer and the ring-shaped pin at its end rotate—again due to centrifugal force—driving the pin into the contact mechanism at the end of the breech. This ignites the SD pyrotechnic delay compound located in a tube inside the breech. When the breech is fully extended, a pin on the reverse side locks it in place. With the wings deployed, the rotational speed slows down; this is because high rotational speed can reduce the effectiveness of the cumulative charge. Upon impact, the striker strikes the impact-sensitive detonator, which activates the high-explosive grenade and the main charge. If this fails to work, the pyrotechnic delay will activate 15 seconds after the detonator is triggered (usually 5–7 seconds after impact).

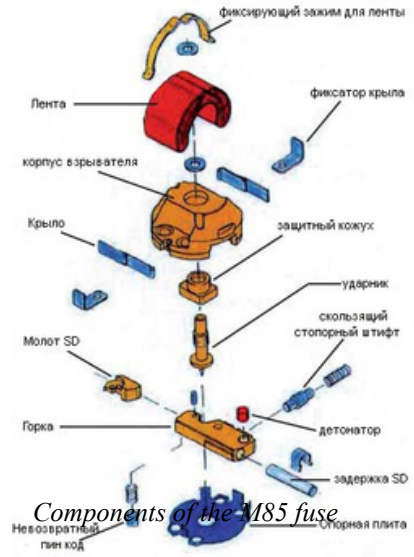

Components of the M85 fuze

When the main charge detonates, the steel rings surrounding the casing shatter, creating a fragmentation effect. This results in approximately 700 steel fragments, each of which is a 3-mm-thick cube weighing about 200 mg. Another 500 or so fragments of various shapes and sizes are formed from the inner aluminum lining and the end caps. Upon detonation, the fragments reach speeds of 700–850 m/s and can be lethal at a distance of 10–12 meters. In addition, upon detonation of the main charge, the conical copper shaped-charge liner transforms into a high-velocity jet directed forward along the axis of the bomb's casing and capable of penetrating armor. This jet is capable of penetrating steel armor approximately 100–120 mm thick, creating a hole about 10 mm wide.



Cluster munition

IMO cluster munitions are designated CL 3013-E1, which corresponds to the M396; these are extended-range munitions designed to disperse 49 submunitions. The figure shows a cross-section of the German DM662, which is comparable to the M396.

The M39 and M864 shells, which carry M85 bombs and other DPICMs, are equipped with fuses that the gun crew sets to detonate at an altitude of 400 to 600 m above the ground. When the fuze is triggered, a propellant charge in the front of the shell ignites. This charge ejects the submunitions from the rear of the shell, and the shell's rotation helps disperse them. Upon impact with the ground, the submunitions cover an elliptical area.

A key feature of this ammunition is that its maximum range is 45 km under ideal conditions, which is exactly half that of standard charges for HIMARS.

One of the carriers for the M85 and M87 submunitions is the Israeli-made 120-mm M971 mortar round.

The IMI M971 DPICM shell contains 24 or 32 M85/M87 submunitions. The shell covers an area of 1 hectare with submunitions at a range of up to 6.2 km.

The position of the empty shell casing depends on the angle of impact. At low angles, the shell lands some distance in front of the submunitions, while at high angles, it lands closer to them.

This munition is used by Ukrainian fascists in all theaters of operations

M6A2 Anti-Tank Mine (USA)

Anti-tank anti-track mine. Designed to disable enemy tracked and wheeled vehicles.



Enemy vehicles are destroyed by the destruction of their undercarriage when the mine charge explodes as a wheel (track) strikes the mine's pressure plate (M600 or M603 fuse).

The version with the M600 fuze was designated M6A1, and the version with the M603 fuze was designated M6A2. The mines were manufactured by the United States in 1941 during World War II. According to strict regulations, such munitions were supposed to have been destroyed as early as 1976.

In the United States, they were phased out in the late 1960s, and there are no stockpiles of these mines in storage. However, a significant number of these mines were sold to countries in Asia, South America, and Africa. They were widely used in the Korean War in 1952–53.

In particular, about 1 million mines were transferred to the South Vietnamese government forces between 1965 and 1970.

It was adopted by the U.S. Army in 1949. It was formally decommissioned in the late 1960s and replaced by the M15 mine.

Main Specifications

Mine weight: total.....	9.1 kg
Explosive (TNT).....	5.4 kg
Dimensions: diameter.....	33 cm
Height.....	8.3 cm
Diameter of the pressure cap (target sensor).....	20 cm
Actuation force	158–338 kg Self-
destruction/self-neutralization	no/no

The M6 mine has the classic disc shape typical of anti-tank mines. The casing is made of sheet metal. On top is a protruding, breakable cover—which also serves as the pressure-activated target sensor. In the center of the cover is a socket for the fuze, sealed with a plug. The crushable cover transmits force through a disc spring (*Belleville spring*) to the striker, which then pierces the intermediate detonator.

The M600 or M603 pressure-activated fuze is inserted into the fuse socket in the center of the pressure cap; to do this, the plug must be unscrewed. The plug also serves as a device for setting the mine to the safe or combat position. It has a rotary handle with an arrow and the inscriptions ARMED ("armed"), SAFE ("safe"), and DANGER ("danger"). Turning the handle in one direction or the other using a special wrench (shown in the figure next to the mine) shifts the arc-shaped plate located on the underside of the plug. If the handle is turned to the SAFE position, the arc-shaped plate will be positioned so that when pressure is applied to the mine's pressure cap, it cannot press down on the detonator's pressure rod, and the detonator will not be triggered.



The fuze itself has a removable safety pin with a ring as a safety mechanism, which must be removed before inserting the fuze into the mine.

The mine detonates when the pressure cap is struck.

The M600 fuze has a very simple design. Inside the metal housing (9) is a detonator cap (1), with a cube of ignition compound (2) above it. A glass ampoule containing a liquid chemical reagent rests on a ring-shaped anvil. A curved leaf spring (6), resting on the fuze cover, fits into a slot in the rod head (7) with its notch.

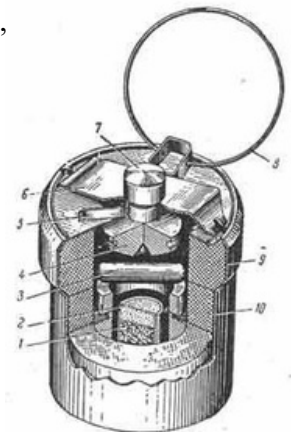

The rod (4) itself hangs over the ampoule. A safety pin (5) with a pull ring (8) is inserted under the leaf spring. The remaining space in the detonator housing is occupied by an intermediate detonator (9) made of compressed TNT.

Before installing the fuse into the mine, the safety pin is pulled out using the ring. From this point on, the fuse is in the armed position. It is carefully lowered into the socket of the mine's detonator, from which the plug with the handle for setting the mine to the armed or safe position has been unscrewed beforehand. Next, check the position of the handle; its arrow must point to the word "SAFE." After that, the plug can be lowered onto the socket and turned clockwise. The mine is armed and in the safe position.

When the rod head is pressed (while the mine is in the armed position), the rod overcomes the resistance of the leaf spring, moves downward, and crushes the ampoule. The liquid spills onto the ignition compound disc. A chemical reaction causes a flash of fire, which ignites the detonator cap. This triggers the intermediate detonator and, subsequently, the mine's main charge.

Fuses of this type are generally very dangerous to handle due to the fragility of the glass. The ampoule may leak due to cracks in the glass, which can form at any stage of transport or handling of the fuse as a result of jolts, impacts, drops, nearby explosions, or even simply due to internal stresses in the glass. The M600 fuse is particularly dangerous because it contains both a detonator cap and an intermediate detonator, the explosive charge of which is large enough to cause serious injury to a deminer in the event of an unauthorized detonation. And there is no way to check the condition of the ampoule containing the chemical reagent, since the fuse is hermetically sealed.

M600 fuses are completely obsolete, and you're unlikely to encounter them. In our current context, M6 and M15 mines may be equipped with M603 fuses, which are simple, mechanical devices.

There are sockets on the side and bottom for M5 or M142 fuses with M1 intermediate detonators. These fuses ensure that the mine cannot be removed. They detonate when an attempt is made to remove the mine from its installation site.

Their appearance in our theater of operations indicates that the enemy is gradually running out of Soviet TM-62 mines. So far, only a few of these mines have been spotted in Ukraine, but the fact remains. Exactly where they came from—and from whose remaining stockpiles—is unknown, and it is not that important.

Device

- 16 – safety device;
- 2 – safety device block;
- 14 – firing pin head;
- 4 – KD;
- 7 – intermediate detonator;
- 8 – main explosive charge;

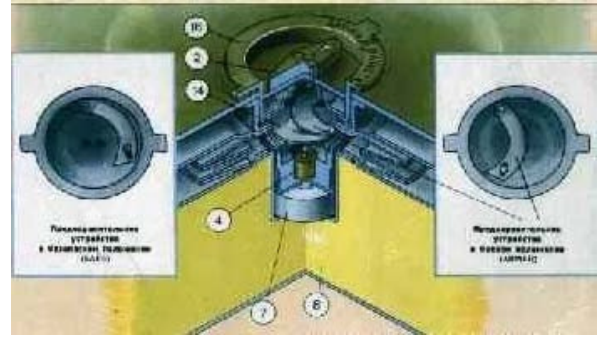

It has a rotary knob with an arrow and the following

*inscriptions: **ARMED** – indicates that the fuse is set;*

***SAFE**—“safe”; this is the safety position; even if the cover is pressed and crushed, there will be no explosion, as the pressure will not act on the detonator’s firing pin and will simply pass through the mine;*

***DANGER** – “dangerous,” combat mode.*

Turning the handle in one direction or the other shifts the arched plate located on the underside of the cap. If the handle is turned to the SAFE position, the arched plate will be positioned so that when the

cover, it will not be able to press against the detonator’s trigger plate, and the detonator will not be triggered. The detonator itself has a removable safety clip that must be removed before inserting the detonator into the mine. In addition to the standard detonator, the seal contains an M603 detonator inside.

M603, two additional fuses are available:
bottom



A key for opening the sealing canister is located at the

- **M624 detonator** (screwed into the main socket in place of the plug with a rotary handle), used as an inclined-action detonator (with an extension rod—a 61-cm-tall pin-type target sensor) or as a pressure-action detonator (the extension rod is not inserted into the fuse socket). It enables an attack across the entire width.

- 1– safety limiter;
- 2– hole for screwing in the fuse;
- 3– plug;
- 4– gasket;
- 5– safety pin;
- 6– safety clamp;
- 7– pressure ring;

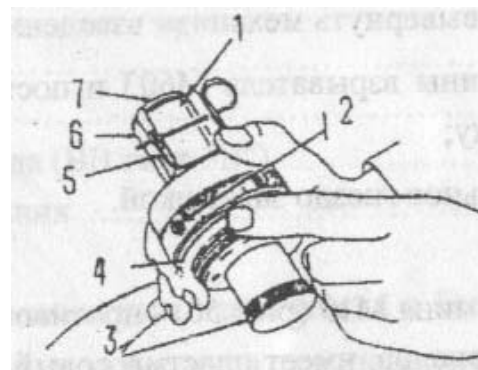

– The **M608** pressure-activated dual-pulse fuse is designed to be highly resistant to explosive ordnance disposal methods. The M608 fuse does not detonate the mine when the first tank drives over it: instead, it is designed so that the mine detonates when a second vehicle (such as an APC or, possibly, a truck towing a howitzer) follows in the first tank’s tracks—an event that may occur seconds, hours, or even weeks later. The M608 dual-pulse fuse is particularly useful when installed on mines located at the outer edges of minefields, as it gives tanks a false sense of security.

The lead tank, for example, can trigger more than 30 mines equipped with two-pulse fuses without detonating a single one. This lures tanks deep into the minefield, where they ultimately trigger mines equipped with M603 or M624 fuses (both of which operate exclusively in single-pulse mode) and fall into a trap. Attempts to retrieve the tanks or rescue the casualties are hindered by the fact that the mines mounted on the M608, which were previously set in motion, now operate in single-pulse mode, and also because minefields containing M15 mines typically also contain various anti-personnel mines, such as the M14 mine and the M16 boundary mine. An additional advantage of dual-pulse fuses is that they provide the mines with a certain degree of protection against demining methods that use excess blast pressure or mine roller systems.

Operating Principle of the M15 Mine

When pressure is applied to a mine set in the combat position (the safety device’s indicator is aligned with the word “ARMED”), the pressure cap lowers, overcoming the resistance of the leaf springs. In doing so, the pressure is transmitted to the firing pin head. The striker pierces the detonator’s initiator, causing the initiator, the intermediate detonator, and the main explosive charge to detonate.

The mine can also detonate if one of the non-extractable fuses, screwed into the socket, is triggered.



A typical configuration of overload protection devices

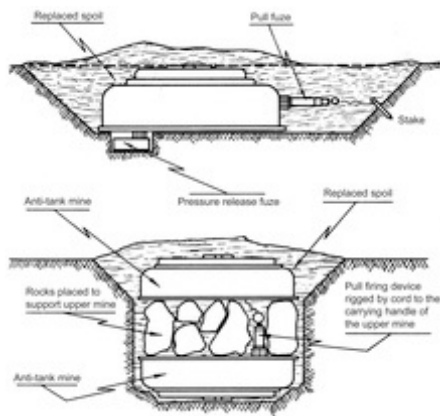

used with M15 mines. The top diagram shows a pull-out fuse screwed into a secondary fuse hole on the side of the shaft. In addition, an M5 safety device was screwed into another fuse hole hidden beneath the mine. An inexperienced sapper may discover and disarm the safety device, but will then be killed when he picks up the mine, triggering the M5 detonator beneath it.

The diagram below shows two anti-tank mines connected by a cord attached to the carrying handle of the upper mine. The cord is attached to a pull-type fuse installed in the secondary fuse hole in the lower mine.

There are sockets on the side and bottom for M5 or M142 fuses with M1 intermediate detonators.

These fuses ensure that the mine cannot be removed.

They are triggered when an attempt is made to remove the mine from its installation site.

M5 relief fuse (shown on the left), and the M142 is a tension-type fuse (pictured on the right).

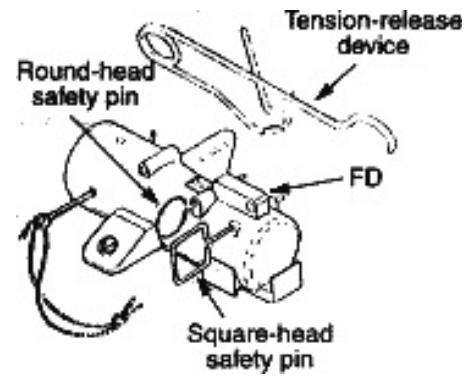
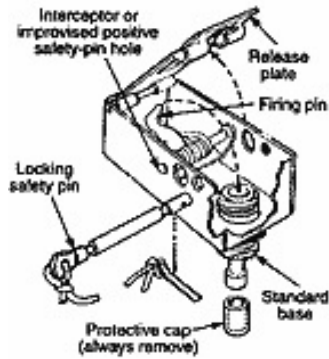

The mines are packed in boxes, one per box (gross weight 18 kg), not fully assembled (without a fuze or detonator).

Defusal Procedure

1. Carefully remove the camouflage layer from the mine.
2. Move the mine from its installation site using a "cat."
3. Place the mine in a safe position, aligning the arrow on the safety device's base with the word "SAFE" on the rim of the safety device.
4. Unscrew the safety device (threaded plug) from the pressure cap and remove the detonator from the ignition cup, having previously installed a safety plug under the detonator's head.
5. Screw the safety device (threaded plug) into the socket on the pressure cap.

The M6 and M15 mines are used as drop munitions from large agricultural drones ("Baba Yaga," "Vampire"), equipped with a makeshift fuse.



In 2024, this mine also appeared in the Ukrainian Armed Forces. In December 2024, they were detected in the Kurakhovsk direction. So far, they have only been found with the M603 fuse, but the enemy may also deploy the M624 with a pin-type target sensor (the pin is 61 cm tall).

M19 Anti-Tank Mine (U.S.)

Anti-tank, anti-track mine. Designed to disable enemy tracked and



wheeled vehicles. Damage to enemy vehicles is inflicted by destroying their undercarriage when the mine chargedetonates as a wheel(or track) strikes the mine's pressure plate. Developed in the United States. The mine was adopted in the mid-1950s but remains in service with the U.S. Army to this day.

It is manufactured under license in countries such as Chile, South Korea, and Turkey.

Since it is made almost entirely of plastic, the mine is difficult to detect with metal detectors.

The mine uses an M606 pressure-activated fuse. It, too, is almost entirely made of plastic.

Main Technical Specifications

Mine Type.....	anti-tank, anti-track, high-explosive
Casing material.....	plastic
Weight: total.....	12.5 kg
Explosive charge ("B" – 59% hexogen, 40% TNT, 1% wax)	9.5 kg
Intermediate detonator (hexogen).....	51 g
Dimensions: length.....	33 cm
Width.....	33 cm
Height.....	7.5 cm
Diameter (DC).....	25.4 cm
Primary fuse.....	M606 (mechanical)
Fuse activation force.....	136–227 kg
Time to arm the mine.....	immediately after
life	the fuse switch Operational Unlimited
Non-retrievable fuses.....	M5, M142 (both with M2 activator)
Self-destruction/self-neutralization	No/No
Retrievability/Defusing.....	No/Yes
Operating temperature range	-40° to +52 °C

The mine can be deployed manually on the ground, in the ground, in snow, or underwater. The U.S. Army does not have any mechanized deployment systems for this mine.

Structurally, the M19 mine consists of a square plastic casing containing 9.5 kg of explosive. The top of the casing has a recess (socket) for the M606 pressure-activated fuse, the upper cover of which also serves as

a target sensor. On the sides and bottom of the casing, there are sockets for non-retrievable fuses.

The fuse consists of a pressure plate, a Belleville spring, a position-setting knob, a stop plate, a firing pin assembly, and a detonator.

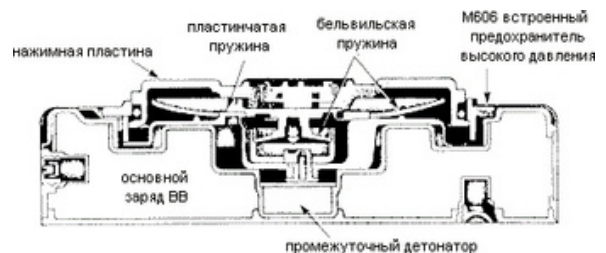

General structure:

- 7– pressure cover;
- 8– leaf springs;
- 9– intermediate detonator;
- 6 – detonator cap;
- 10– firing pin;
- 11– detonator pressure head;
- 12– main explosive charge;



Fuse assembly:

- 13– ignitioncup;
- 10– firing pin;
- 11– detonator pressure head;
- 8– leaf springs;
- 6 – detonator cap;
- 9– intermediate detonator;



The mine is placed in a box with a fuse inserted into it, but without the detonator, which is stored in the same box in a separate container. To prepare the mine for use, first ensure that the rotary handle on the mine's top cover is turned to the "S" position and secured with the safety pin; then, using the M22 special wrench, remove the fuse from the mine by turning it counterclockwise 45 degrees. Then screw the detonator into the fuse and reinstall it in the mine. Safe handling of the mine is ensured by the rotary handle located on the upper surface of the fuse's pressure plate, which has two positions: S (safe) and A (armed). To



accidental rotation, the handle is secured by a safety pin with a long cord.

Once the primed mine is placed in the hole, it is set to the combat position. To do this, the safety pin must be pulled out and the handle turned to the A position. The fuse has no time delay when set to the combat position, and the mine becomes dangerous the moment the handle is turned.

The mechanical fuse makes this mine reliable across the entire temperature range, and it can be said that it is in no way inferior to the Soviet TM-57 and TM-62 mines.

Defusing

Mine disposal is performed in the reverse order. However, if the handle cannot be moved to position S, if the safety pin cannot be inserted, or if the fuse cannot be removed from the mine after these operations have been performed, then such a mine is considered undismantled and must be destroyed on site by detonating an external charge.

The marking is embossed and painted yellow. It is located in the lower right corner of the upper surface of the casing and contains:

***This mine appeared in the Ukrainian Army in 2025 (among instructors).
The exact location of its discovery is not yet known.***

M 21 Anti-Tank Mine

Designed to disable enemy tracked and wheeled vehicles.



When used as an anti-bottom mine, damage to enemy vehicles is inflicted by a cumulative jet piercing the vehicle's bottom upon detonation of the mine's charge, at the moment when the vehicle's hull deflects the pin-type target sensor by 10–12 degrees from the vertical position. When used as an anti-track mine, the mine damages enemy vehicles by destroying 1–3 track links and damaging the vehicle's road wheel with a cumulative jet upon detonation of the mine's charge

at the moment the track exerts a force of at least 130.5 kg on the fuze. The mine is installed manually in the ground, in snow, or underwater.

The mine has an unlimited operational life. The mine is not equipped with a self-destruct mechanism, anti-extraction devices, or anti-disarmament features, and there are no slots for installing such devices in a non-removable position.

Mine Specifications:

Mine type.....	Anti-tank, anti-bottom/anti-track;
Casing	metal;
Weight: mine.....	7.8 kg;
Explosive (type "H6").....	4.5 kg;
Dimensions: mine diameter.....	23 cm;
body height.....	11.5 cm;
Target sensor height (pin).....	51.1 cm;
Sensitivity (with pin).....	20 degrees from vertical with a force of ≥ 1.7 kg.
Pressure sensitivity.....	130.5 kg;
Operating temperature range	30–+50 degrees; Fuse
used	mechanical M-607.



General mine configuration:

- 1– main explosive charge
- 2– M120 auxiliary detonator;
- 3– plug;
- 4– powder delay;
- 5– carrying strap;
- 6– M42 fuse;
- 7– concave steel plate;
- 8– plug;
- 9– expelling charge (black powder);
- 10– firing pin;

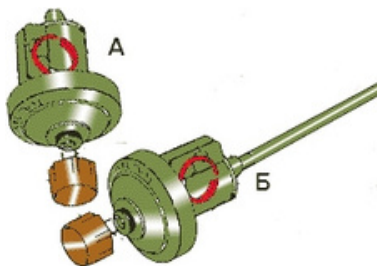
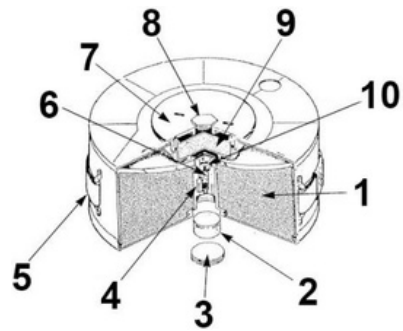

The M607 fuse can be used as a pressure-activated fuse (Variant A). In this case, the pin is not screwed into the fuse.

It can also be used as a tilt-action fuse (Variant B). In this case, a 51.1 cm long pin is screwed in. The figure shows the M607 fuse in both variants.





M607 fuse

- 1– pin;
- 2– pressure ring;
- 3– clamp;
- 4– pull ring;
- 5– plug;
- 6– cap;
- 7– split pin;
- 8– pin;

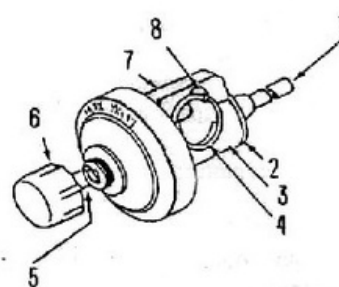

The mine is installed in a hole 22–25 cm deep so that only the target sensor (pin) remains above the ground surface, with a height of at least 50 cm above the ground. Before the mine is finally camouflaged, the retaining ring on the safety device is pulled out and the safety device—a hollow metal half-cylinder that prevents the pin from deflecting when the device is in the safe position—is removed. The fuse has no temporary safety mechanism and is in the armed position from the moment the safety device is removed. This is a significant drawback of the mine, as the final camouflaging of the mine with turf or soil must be carried out with the utmost care.

When pressure is applied to the upper part of the M607 fuse by a tank track with a force of 130.5 kg (if the fuse is without a pin) or when the tilt sensor (pin) is deflected by 20 degrees with a critical force of 1.7 kg, the disc

plate (Belford spring) is pressed in. The firing pin is released and strikes the M46 primer. The black powder charge is detonated. This preparatory explosion blows off the mine's cover, and if the munition was covered with soil (debris, snow, ice), it also dislodges all of the aforementioned material. This is necessary to clear space for the proper formation of the cumulative charge (*armor-piercing projectile*). The same M46 primer ignites

the delay fuse, and after a delay of a fraction of a second, the M120 intermediate detonator is initiated. The explosion of the latter then “triggers” the mine's main explosive charge. The projectile is formed and strikes the underside of the vehicle, which happens to be directly above the mine at that moment. The cumulative jet pierces the bottom of the vehicle, or 1–3 track links are destroyed and the road wheel is damaged.



Disarmament:

The standard M21 configuration does not include means for securing the mine against removal. However, the absence of factory-made sockets for additional fuses does not mean that the enemy will not install them improvised, simply by using a drill or even just a sturdy knife... As is often the case with the TM-62, which also lacks standard additional sockets for fuses (*unlike, for example, the TM-57 and some Western models*). An enemy could place a grenade underneath or install another mine from below (standard MS-3, ML-7, ML-8, or something non-standard).

The following are used with M21 mines:

- M607 – mechanical, basic (with a pressure or tilt sensor).
- M612 – pneumatic.
- M609 – non-contact magnetic, triggered by metal at a distance.

There is very little information available on the latter two. In Donbas and Novorossiia, M21s have so far been identified only with the M607. There are no reports of deliveries of other fuses. But the confrontation with the West is set to last a long time, and anything is possible, in this or other theaters of operations...

Sequence of steps:

- 1.) Carefully, without touching the pin, set the safety;
- 2.) Unscrew the stem with the holder;
- 3.) Remove the camouflage layer from the mine and unscrew the fuse;
- 4.) Extract the mine from the ground using a mine detector (it may be a booby trap);
- 5.) Unscrew the base plug;
- 6.) Remove the detonator and screw the plug back in;

The mine was discovered during a search and clearance operation in the Rubtsovsk area; it was an anti-track variant without a pin.

L9A2 "bar mine" anti-tank mine (United Kingdom)

The L9A2 mine is a large rectangular anti-tank landmine.

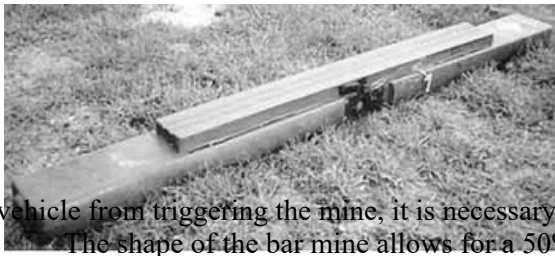

The main advantage of the bar mine is its great length and, consequently, its long trigger zone. A typical anti-tank mine is round, and a vehicle's wheels or tracks—which make up only a small fraction of its total width—must actually press down on the mine to activate it. To increase the likelihood of a

a vehicle from triggering the mine, it is necessary to increase the mine's effective trigger width.

The shape of the bar mine allows for a 50% reduction in the number of mines in a minefield without reducing its effectiveness.

The mine is made of plastic and cannot be detected by metal detectors. A metal plate is attached to bar mines, which is intended for subsequent retrieval by friendly forces, usually for training purposes. For the bar mine, a full-width fuse (FWAM) and an anti-jamming fuse are available; they are mounted at the ends of the mine, near the pressure plate. There were two types of FWAM fuses—one mechanical and one electronic. They were mounted at the end of the pressure plate opposite the ACP. Mines equipped with these fuses were laid using a bar mine layer. Adopted by the British Army in 1969.

Main Technical Specifications

Casing material.....	polyethylene
Mine dimensions: Length.....	120 cm;
Height (with target sensor).....	8.2 cm;
Width.....	10.8 cm;
Weight: mines	10.2–10.6 kg;
Explosive: TNT (or Hexotol 3A).....	8.4 (8.8) kg;
Length of the mine's target sensor (rubber tube filled with liquid) –	74 cm;
Fuse.....	L89a1 – hydromechanical.
Fuse activation force	180–260 kg; Operational life
.....	Unlimited.
Operating temperature range	-20 to +40°C (determined by the hydraulic
	fluid in the fuze.

Mines do not have mechanisms for self-deactivation, self-destruction, non-neutralization, or non-retrieval. The fuze operates on the principle of transmitting fluid pressure from the pressure cap to the fuze mechanism. It consists of a pressure housing, an actuator, a cap, an arming mechanism, and an intermediate detonator. To arm the fuze, remove the safety pin and turn the fuze mechanism 90 degrees clockwise to the "A" (Armed) indicator; this will move the primer onto the striker's axis of motion.

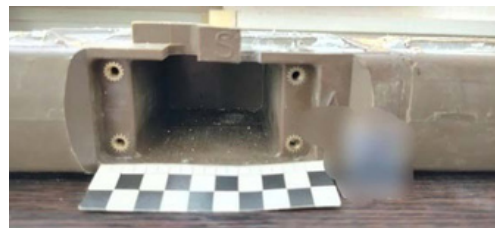

To set it to the safe position, turn the mechanism 90 degrees counterclockwise to the "S" (Safe) indicator and insert the safety pin (a wire of the appropriate diameter) and secure it. The L9 mine has variants A1–A4, which differ in the explosive used, as well as slightly in size, plastic type, and detonators.



The mines are produced with four types of fuses:

- L90A1 – mechanical;
- L89a1 – hydraulic;
- M29 – mechanical pin-type;
- L128a1 – electromagnetic.

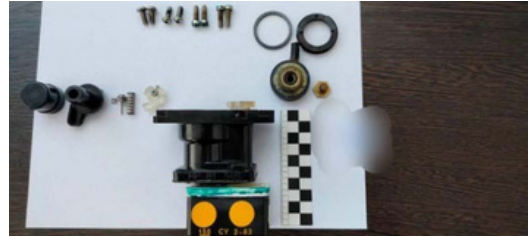

The fuze marking is applied to the fuze itself on the side of the mine, while the mine markings are applied to both ends of the mine.

The date of manufacture and the manufacturer are indicated on the marking on the bottom of the mine. The explosive used in the mine is indicated on a yellow adhesive tape.

Disarmament:

- Remove the protective covering;
- Turn the arming lever counterclockwise so that it assumes an approximately vertical position (if normal force is insufficient, destroy the mine with an external charge);
- Secure the arming lever with a safety pin and remove the mine from the hole, after first ensuring that it does not have an anti-extraction feature;

**L18A1 Anti-Tank Mine
(United Kingdom)**

This mine is identical to the L9A2 mine, except for its weight specifications.

Main Technical Specifications

Casing material.....	polyethylene, plastic
Mine dimensions: Length.....	120 cm;
Height (with target sensor).....	7.8 cm;
Width.....	10.8 cm;
Weight: mines.....	10–10.2 kg;
Explosive: TNT (or Hexotol 3A).....	8.2 (8.4) kg;
Length of the mine's target sensor (rubber tube filled with liquid) –	74 cm;
Hydromechanical fuse.....	L89a1
Fuse activation force	180–260 kg;



The mine is already in use by the Ukrainian Armed Forces on the LBS

AC ID 51/52 anti-track mine (France–Belgium)

A caseless, pressure-activated, high-explosive anti-tank anti-track mine.



The mine was adopted in 1951. As of 2016, it is not a standard-issue mine of the French Army; however, it is being studied at the Engineering School, and there is reason to believe that certain stocks of these mines are held in army warehouses.

Versions of this mine are produced under the designations AC ID 52 in France, STM 1 in Singapore, and Nr26 in Pakistan.

Mine color: Typically orange-brown.

In Belgium, it is designated as **Pansermine M/56**

Main Specifications:

Weight: total.....7.4 kg
 Explosive (TNT).....7.2 kg
 Diameter.....30 cm
 Height.....11 cm
 Diameter of the pressure target sensor.....16.5 cm
 Activation force . . . 225–350 kgf Temperature range . . -40° to +50°

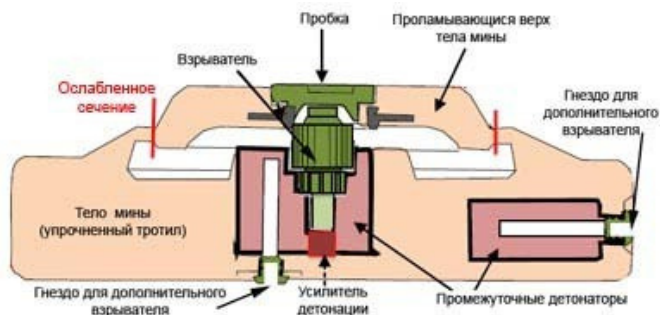

However, when equipped with appropriate fuses, it can be used as a high-explosive anti-bottom mine or as a high-explosive anti-track and anti-bottom mine. The mine is deployed on the ground or in the ground (in water) manually only. Deployment using mine layers is not provided for. Using a side-mounted or bottom-mounted additional tension-type fuse, it can be set to be non-retrievable.

Structurally, the mine is a complex disc-shaped solid of revolution made of hardened TNT reinforced with fiberglass (not a fiberglass shell, but fiberglass embedded in the TNT mass). Inside the mine body are two intermediate detonators, which are blocks of compressed TNT with recesses for the fuses carved out inside them. The central block has sockets for the main fuse and for the bottom auxiliary fuse. In addition, at the bottom of the socket there is a tablet of compressed tetryl, which serves as a detonation booster. The side block has a socket for an auxiliary fuse.

Plastic threaded sleeves are pressed into the sockets for the auxiliary fuses on the outside and are sealed with plastic threaded plugs. The upper surface of the mine body has an opening through which the main fuse is inserted; this opening is sealed with a threaded Bakelite plug. The mine body is designed such that there is a cavity beneath its upper section, and the edges of the protruding upper section have a weakened cross-section. As a result, when a force of 225–350 kg is applied to the upper protruding part of the mine body, it breaks through and drops downward, causing the fuse to detonate. A rope with a wooden tube attached to it is inserted and secured into the side of the mine body; this tube is used to carry the mine. On the side opposite the handle, a shock-absorbing element in the form of a rubber block is embedded into the mine's side surface. The mine is placed in the container with this side facing down.

The main fuse is the Ap AC ID 61 (also designated as Al Pr AC ID 61) with an ID 50 detonator cap. The fuse is a pressure-activated friction fuse. The ID 50 detonator cap is a separate component and consists of a plastic tube filled with an initiating explosive (lead azide).

It has a flange at the top, which allows it to be secured to the detonator using a cap nut. The detonator has no safety devices. The force required to activate the detonator itself is **approximately 50 kg**.

Detonator Design.

All components and parts of the detonator are housed in a plastic casing (1). The top of the casing is sealed by a cap (2) made of flexible plastic. A plunger (3) is embedded in the cap a plunger (3) is embedded, on the lower bevel of which the ignition composition (5) is located. In addition, the lower part of the plunger has a needle that, as the plunger is lowered, pierces the casing (8) of the flame booster (7). A sleeve (4), which is cut into four segments at the bottom, serves as the plunger guide. The inner surfaces of the segment bevels are coated with a grating compound (6). The housing has a threaded fitting at the bottom, onto which a cap nut (9) is screwed. The nut holds the detonator cap (10), which has a flange at its upper end.

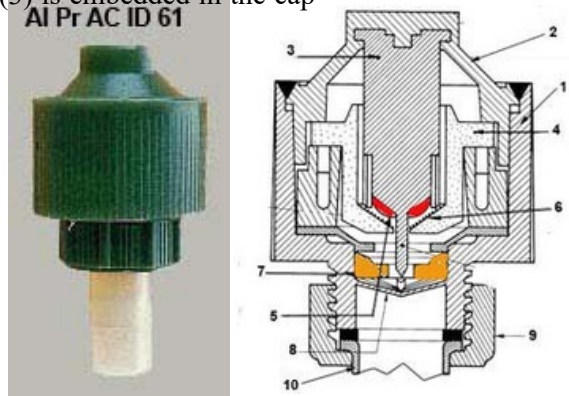

Function of the detonator.

If a force exceeding 50 kg is applied to the head (2) in a vertical direction from top to bottom, the plunger (3) moves downward, overcoming the resistance of the sides of the head and the segments of the sleeve (4). As this happens, the sleeve segments begin to spread apart and exert friction on the ignition composition (5). Simultaneously, the plunger needle pierces the casing (8) of the flame booster (7). The force of the flame from the ignition composition ignites the flame booster. The flame reaches the detonator cap, which explodes.

In addition, other detonators may be used:

AL TENT F1 – a fuse for using the mine as an anti-bottom and anti-track mine;
 AL BS ID F1 – a fuse for using the mine as an anti-bottom mine;
 AT M M1e51 – non-retrievable fuse;

Mine installation procedure:

- Place the mine in a hole or on the surface.
- Use a wrench to unscrew the Bakelite plug.
- Remove the safety sleeve from the socket, take the fuse from the “ ” case, and insert the detonator into it.
- Insert the fuse into the socket without applying force. The mine is now armed!
- Screw the Bakelite plug back into place:



Mine neutralization or destruction:

The mine is deployed on the ground or in the ground (in water) only by hand. Deployment using mine-laying devices is not provided for. Using a side-mounted or bottom-mounted tension-activated auxiliary detonator, it can be set to be non-retrievable.

The mine's concealment lies solely in the fact that it contains no metal parts and cannot be detected using an induction metal detector (mine detector). However, it can be detected with a conventional probe and, nowadays, with radio-wave mine detectors such as the Soviet RVM-2.

The mine is destroyed at the point of detection using a 200-gram charge of plastic explosive applied to the side of the mine.

If the mine is not set to be non-retrievable, it is entirely possible to unscrew the cap, turn the mine over, and simply shake the fuse out of it.

The Danish government announced deliveries of anti-tank mines to Ukrainian fascists in April 2022. They were used particularly extensively in the Avdiivka area of the Donetsk region, as well as along the Krasnyi Liman–Kremennaya axis.

Pansermine M/47 Anti-Track Mine (Denmark)

PM M47-I

Metal casing; anti-tank, anti-track (high-explosive) pressure-activated mine; uses M47-I or M47-II fuses.

When using the M47-I pressure-activated fuse, pressure of approximately 250 kg applied to the pressure plate causes the shear pin to break, releasing the spring-loaded striker. The striker activates the primer and initiates the explosive charge.



When using the M47-II pressure-activated fuse, the pressure plate is screwed onto the landmine during installation; the piston is forced downward, breaking the safety pin. The shear pin rests against the top of the fuse housing, and the fuse is armed.

Pressure applied to the pressure plate pushes the piston, shearing off the shear pin. Further downward movement causes the balls to be released from that are holding the firing pin. The balls move outward, releasing the firing pin, which, driven by its spring,

is pressed into the primer, initiating the explosive.

The second fuse (M47-II) is armed upon installation and detonates upon removal.



The mine was used by Ukrainian Armed Forces units during the special military operation in Ukraine

Stridsvagnsmina m/52B anti-track mine (Sweden)

Anti-tank anti-trackmine. Designed to be disarmed



enemy tracked and wheeled vehicles.

Enemy vehicles are neutralized by destroying their undercarriage when the mine's charge detonates the moment a wheel (roller) strikes the five-pronged pressure plate protruding above the hull.

The mine can be laid both on the ground and in the ground or in snow by hand. Due to the design features and the fuses used, it cannot be laid using mechanical means or remote mining equipment.

Main Technical Specifications of the Stridsvagnsmina m/52B mine

Mine Type.....	anti-tank, anti-track, high-explosive
Casing material (.....)	plywood covered with sealing fabric
Weight: total.....	9.5 kg
Explosive.....	8 kg of hexotol (or 7.5 kg of TNT)
Diameter.....	34.5 cm
Height.....	7.2 cm
Height at the target pressure sensor.....	15.2 cm
Diameter of the target pressure sensor (crosspiece).....	8 with m
Actuation force of the target sensor: immediately at 2–3 horns	200 kg
per horn.....	100 kg
per tilt sensor.....	Approx. 14–15 kg
Time to combat readiness.....	immediately after the DC is engaged
Operational duration.....	Not specified
Primary fuse	m47 with target sensor m/49 (cross-shaped) Alternative fuses.....
	M47 with M/ 49 target sensor (extended rod); Stridsvagnsmintandare 4
Operating temperature range.....	from -40° to +50°
Defusability / Retrievability.....	No/No or Yes/Yes
Self-destruction / Self-neutralization.....	No/Yes

Apart from their unusual shape, there is nothing special about the “m/52 B” mines. M , power , f , and blast effect comparable to the domestic TM-62. However, the simple fuse is not particularly safe and clearly lags behind Soviet designs from the 1960s, which remain relevant to this day (*MVB-62, MVP-62, and others*).

The mine's operational life is not specified in the instructions. It obviously depends on the resistance of the casing (plywood) to decay. If the casing is damaged, proper operation of the target sensor cannot be guaranteed.

The mine's disc-shaped casing is made of plywood and is completely filled with either a mixture of TNT and hexogen (hexotol), or melted TNT. At the center is a block of compressed TNT, which acts as an intermediate detonator. The M/47 fuse is housed within the cavity of this block.

A strap is threaded through slits in the side wall of the casing, with a wooden tube fitted over it. This serves as a handle for carrying the mine.

The socket for installing the fuse and the target sensor is framed by a threaded metal cup. There is a hole in the bottom of the cup that leads to the intermediate detonator—a washer made of compressed TNT. During storage and transport, the cup is sealed with a threaded plug.



Sets of fuses and target sensors are stored in individual sealed containers in special compartments of the crates, next to the mines.



The m/47 fuse and its individual packaging



M/47 Fuse inserted into the mine's socket

Sockets for installing additional The mine does not have non-removable fuses. Nor does it have non-disarmable devices, but they can easily be improvised. For example, a blind hole is drilled on the side or in the bottom, and some kind of fuse is inserted (an MUV with an MD-5M or an UZRGM from a grenade), the ring is secured with wire to a peg, which is driven into the hole when the mine is installed in the ground.

So you need to be vigilant and have this possibility in mind.

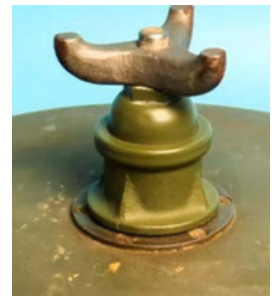

Target sensor m/49, screwed into the mine's socket

The m/47 main pressure-activated fuse with a three-pronged crosspiece (target sensor

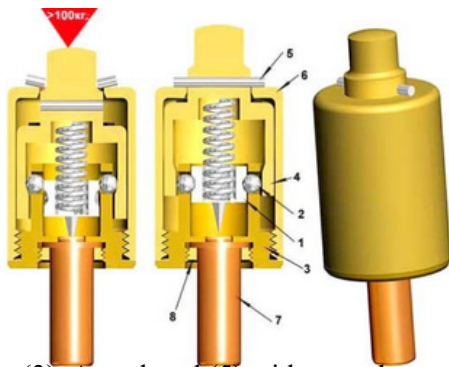

) m/49 is very simple in design and reliable in operation . Installing an extension rod on the target sensor instead of the three-pronged crosspiece itself allows the mine to be used as an anti-bottom mine. However, due to the fact that the mine's charge is relatively small, using the mine as an anti-bottom mine is only effective against unarmored or lightly armored vehicles with low ground clearance.

Structurally, it consists of a casing (1) in the form of a steel sleeve with external threads, by means of which it is screwed into the mine's fuze socket (2). The upper part of the casing is closed by a crushable aluminum

cap (3). A push rod (5) with a mushroom-shaped head at the bottom passes through a hole in the top of the cap. The rod is screwed to the cap with a nut (4). Either a three-pronged crosspiece (6) or an extension rod is screwed onto the upper part of the push rod.

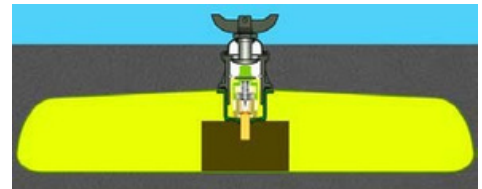

The author does not have information on the length of the extension rod, but it can be assumed that its length is more than 50 cm (so that it can reliably reach the underside of the vehicle).

Inside the housing, when it is screwed into the socket, there is an m/47 fuse, which is inserted into the mine's socket before the target sensor is screwed into it.

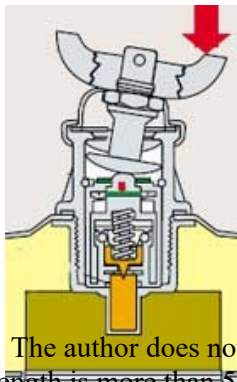

When a track (or wheel) strikes the crosspiece or when the non-extension rod is tilted, the pressure rod, overcoming the resistance of the aluminum cap, tilts and presses its mushroom-shaped head against the fuse's pressure rod. The m/49 target sensor is screwed into the fuse socket. A three-pronged crosspiece or an extension rod can be screwed onto its upper part (the rod). However, the crosspiece is the standard configuration. When a wheel or track strikes this crosspiece, it drops downward or tilts downward and presses on the m/47 fuse rod located inside the mine.

If, however, an extension rod is installed, the target sensor is triggered by the rod's tilt and downward movement.

The author does not have information on the length of the extension rod, but it can be assumed that its length is more than 50 cm (so that it can reliably reach the underside of the vehicle).

Inside the housing, once it is screwed into the socket, there is an m/47 fuse, which is inserted into the mine's socket before the target sensor is screwed into it.

When a track (or wheel) strikes the crosspiece or when the extension rod tilts, the pressure rod, overcoming the resistance of the aluminum cap, tilts and presses against the pressure rod with its mushroom-shaped head.

It should be noted that while the m/41-47 mine can use either the five-legged spider with the m/47 fuse or the m/49 target sensor described here with the m/47 fuse, the m/52B mine can use only the m/49 target sensor with the m/47 fuse.

The manual does not provide for the use of other fuses that, based on their mounting specifications, could be screwed into the mine's socket.

The m/47 fuse (Mintandare m/47), with which the mine is supplied, is the standard-issue fuse. Its design is fairly simple.

A spring-loaded striker (1) is held in place by two retaining balls (2), which are located in a horizontal bore in the base of the fuse (3). These balls fit into the annular groove of the striker, and on the other side, they abut against the widened portion of the push rod skirt (4). The push rod itself is held in place by a shear pin (5), whose ends rest against the top of the detonator housing (6). A percussion detonator (7) is inserted into the bottom of the detonator base and secured with a cap nut (8).

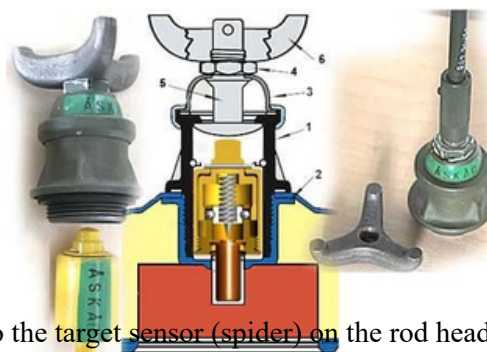

A force exceeding 100 kg (200–400 kg, mentioned in the mine's description refer not to the fuze but to the target sensor (spider) on the rod head (which is pressed by the spider's moving part); the rod begins to lower, further compressing the spring. The shear pin shears off, and the rod continues its downward movement. As soon as the widened part of the rod skirt is below the balls, they are able to roll into the cavity of the rod skirt. The rolling of the balls releases the striker, which, under the action of the spring, moves sharply downward and strikes the primer.

The explosion of the detonator cap triggers the explosion of the intermediate detonator, which in turn detonates the mine's main charge.

The fuse has no safety mechanisms, and the only protection against accidental detonation is the relatively high force required to press the actuator rod. The detonator cap is also unprotected, so a certain degree of caution is required when handling the fuse.

The manual contains no information regarding the fuse's markings. Judging by the photographs, there are service markings in white paint on the bottom of the fuse base. The combat fuse is painted yellow; the inert (training) fuse is painted green; and the disassemblable training fuse is painted yellow like the combat fuse, but the body features a green rectangle containing the word "ASKAD" in black letters.

Alternative fuses:

Stridsvagnsmintandare 4, a mechanical pressure-activated fuse. Equipped with a non-extractable mechanism.

Resistant to the explosions of demining charges. Also used in combination with an explosive charge as a pressure-activated booby trap. The time required to arm the device from the moment the trigger is pulled is 5 minutes. When used

this fuse in m/41-47 and m/52 mines, an adapter with an intermediate detonator is required due to a mismatch between the thread sizes of the fuse sockets in these mines and the thread of this fuse. The adapter is attached to each fuse.



When the Stridsvagnsmintandare 4 fuse is used in a mine, the mine becomes non-retrievable and non-defusable.

The Mintandare 15 is a mechanical tilt/pressure-activated fuse with a pin-type target sensor.

It is triggered when the 65-cm pin is tilted by the vehicle's hull or undercarriage to an angle of more than 30 degrees. The force applied to the pin must be at least 15 kg and last for several seconds, which ensures the fuse's sufficient resistance to various accidental external influences (wind, small airborne objects such as shrapnel, clods of earth, stones, etc.).

The fuse can also be used without the pin. In this case, it operates as a pressure-activated fuse. It is triggered when pressure of 200 kg is applied to its upper part. A distinctive feature of the fuse is that, after the vehicle's wheel impacts the target sensor (the pin or the head), the fuse is activated with a delay. The delay time is set to allow the device to pass through

a roller trawl or any similar devices and to detonate once it is directly beneath the vehicle's hull (under the rear wheel or under the second or third track roller).

There is no precise data on the availability of adapters for the M/52B mine or on deliveries to the Ukrainian Armed Forces.



The Mintandare 16 is a magnetic anti-tank mine that is non-retrievable and cannot be neutralized.

It is triggered by the vehicle's magnetic field when it passes over it. It reacts in the same way when a wheel or track passes over the fuse. If the mine's position changes—such as if it is shifted—the fuse is triggered and detonates the mine. At the same time, the fuse is resistant to any radio-electronic interference, electromagnetic pulses, and nearby explosions.

There is no precise information regarding the availability of adapters for the M/52B mine or deliveries to the Ukrainian Armed Forces.



Mine Installation



The mine is deployed on the surface or buried in the ground. In the latter case, the mine must be buried no more than 3–4 centimeters below the ground surface (measured to the upper edge of the target sensor housing) so that the three-pronged pressure plate crosspiece is above ground level. Otherwise, proper mine activation cannot be guaranteed. The crosspiece itself is camouflaged using readily available materials.



When placed in the ground or snow, the surface of the mine is camouflaged, leaving only the three-pronged “crown” of the target sensor (*or the pin of the inclined sensor*) above the surface.

The mine is stored, transported, and carried with a plug screwed into the fuse socket. After placing the mine in position or in a prepared hole, the plug is unscrewed, and the m/47 fuse is inserted into the socket. Then, carefully, ensuring proper alignment and strictly from above, the m/49 target sensor is inserted and screwed in.

When doing so, the target sensor may only be held by its body and under no circumstances by the crosspiece. From this point on, the mine is in a combat-ready state.

It is strictly prohibited to pre-insert the fuse into the target sensor and then screw it into the mine's fuse socket in this configuration. This is dangerous.



Disarming

Although the mine's casing is made of wood, it contains metal components: the fuse housing, the target sensor, and internal parts of the fuse. Therefore, it can be easily detected with a metal detector. The wooden casing reacts somewhat unusually when probed with a metal detector probe. The steel probe may simply get slightly stuck. It could be mistaken for a tree root, and mines with wooden casings have long been out of use; therefore, a sapper must be vigilant and tuned not only to the TM-62M and other mines with solid metal or plastic casings, but also to Western models like these—caseless ones—or, for example, wooden ones (*Sweden is a northern, forested country, so the choice of material is not surprising*).

The shape and color can be counted among the few advantages of this Swedish mine. Even when simply placed on the surface, it is not as easily recognizable as the TM-62, which is familiar to a sapper's mind. When buried in the ground, the "m/52 B"—camouflaged by field grass and forest litter—is extremely difficult to spot. And since a deminer must train their eye to recognize the sensor's distinctive "crown," it is crucial to familiarize oneself with all munitions used in a specific theater of operations.

Mine disposal is carried out in reverse order.

It's dangerous to try unscrewing the target sensor (*unless you were the one who laid the mine and have been constantly monitoring that section of the minefield*). Otherwise, there is a non-zero risk that the clumsy sapper might have tampered with the fuze. If there are difficulties unscrewing the target sensor or removing the fuze from its socket, the mine must be destroyed on the spot by detonation.

If a mine is detected visually, with a metal detector, or with a probe, it is preferable to neutralize it by detonating it on site using an external charge.

Mine Color and Markings.

The mine is painted olive-yellowish-green (standard) or white (for winter). A colored rectangle is painted on the side of the mine.

A yellow rectangle indicates a live mine.

A green rectangle indicates an inert mine.

A blue rectangle indicates a training mine (the mine may be painted entirely blue).

Inside the rectangle, the letters "m/52B" are stenciled in black.

These mines were used by Ukrainian fascists during combat operations in Ukraine during the Special Military Operation

TMA-4 anti-track mine (Yugoslavia)

The TMA-4 is a round anti-tank mine with a minimal amount of metal in a plastic casing. It is a modernized version of the TMA-3. The mine essentially consists of a cast block



of TNT with three holes cut into it for the fuses, encased in green plastic. During transport, all fuse sockets are sealed with plastic plugs. Three UTMA-4 pressure-activated fuses (chemical) can be easily screwed into (and, accordingly, unscrewed from) the mine; these fuses have a black plastic housing with a mushroom-shaped piston at the top and a detonator with a push-in sleeve, beneath which is a striker, and beneath the striker is a plug with

a membrane, a gritted ignition mixture, and an M-17-P-2 detonator cap M-17-P-2 used in the UPMAH-2 fuse in the PMA-2 antipersonnel mine. Unlike the fuse for the TMA-3, the detonator does not protrude from the base of the TMA-4 fuse, and no metal is visible.



Main Technical Characteristics

Diameter.....	28.4 cm
Height (with fuse).....	11 cm
Weight: mines.....	6 kg
Explosive (TNT).....	5.5 kg
Intermediate detonator (pressed tetryl).....	10 g
Activation force.....	100–200 kg

The three fuses are supplied in specially manufactured sections made of interconnected plastic tubes, along with three steel detector discs that can be buried with the anti-personnel mine or jettisoned. Thanks to this arrangement of the fuses, the total surface area of the target sensor is incomparably smaller while maintaining the same probability of hitting the target. After all, only the upper parts of the fuses protrude above the surface. A short rope handle is attached to a small fourth hole for carrying.

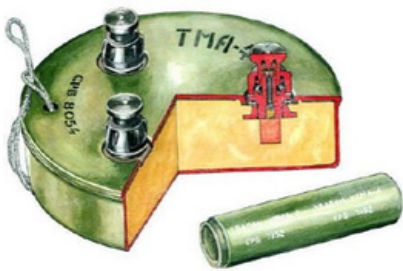

The UTMA-4 fuse is triggered by friction or by pressing the plastic sleeve against the ignition mixture (marked in orange). When the target sensor (the upper end of the fuse) is pressed, the plastic sleeve breaks, striking the igniter. A flame is transmitted to the booster charge (marked in yellow), which triggers the mine's detonation. The upper part of the fuse (marked in red) rotates freely within the housing. Its rotation can cause wear on the fuse even under low loads; therefore, when installing or removing the UTMA-4 fuse, it must be held by the housing (marked in green).

When pressure of approximately 100–200 kg is applied to the detonator's plunger, the collar at the top of the detonator housing shifts, allowing the plunger to push through the diaphragm into a small cap containing a friction-sensitive compound, which ignites and enters the detonator. The only metal part of the fuse (and the mine) is the small aluminum detonator casing. This makes the mine difficult to detect by mine detectors.

The small surface area of the fuse's pressure plate makes the mine resistant to overpressure when explosive demining methods are used. Furthermore, the mine's low metal content makes it very difficult to detect. Although no backup fuse is provided, it is possible that the mine could have been equipped with improvised safety devices.

Mine Installation

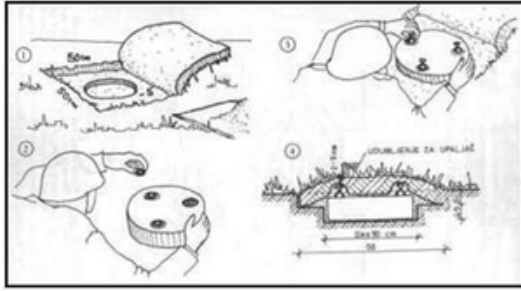

To arm the mine, the plugs must be unscrewed from the mine casing and the fuses screwed in. The mine is placed in a hole deep enough so that the fuses, along with the camouflage layer, protrude 5–6 cm above the surface.

Defusing:

- Check the ground around the mine for explosive ordnance;
- Clear the mine;
- pull the mine out of its cover using a mine-pulling tool (the fiberglass casing is prone to breaking during extraction);
- unscrew and remove all 3 fuses;



The mine is anti-magnetic and watertight. Since the casing of the anti-tank mine is entirely non-metallic, and the only metallic elements are small aluminum



detonator capsules, it is difficult for mine detectors to detect it. The mine does not have a special, additional slot for setting it to non-retrievable mode, but it can be set to non-retrievable mode using relief fuses or booby traps.

Since the mine has no casing, it can easily be dropped from a UAV just like a standard concentrated high-explosive mine.

There is no information on the exact location of the mine on the LBS.

MAT-62B Anti-Tank Mine (Romania)

The MAT-62B is a round anti-tank high-explosive mine housed in a Romanian plastic casing. It is very similar to the Russian TM-62P2. The mine has a central fuze compartment into which a Bakelite R-62 (P-62) pneumatic pressure-activated fuze is inserted, containing a CD-11R detonator. Fuzes from Soviet TM-62 and TM-72 series mines can also be used in this mine.



The mine's low metal content makes it difficult to detect. A casingless MAT-76 mine is also produced.

Main Technical Specifications:

Mine type.....	Anti-track
Casing	Bakelite
Weight: total.....	9.8 kg
Explosive (cast TNT).....	7.2 kg
Actuation force.....	200 kgf
Dimensions: diameter.....	32 cm
Height.....	13.2 cm
Fuse type.....	pneumatic
Installation method.....	manual, mechanized



The fuse is not fully armed. The kit includes special detonator caps that are inserted into a threaded sleeve on the inside of the fuze.

The R-62 has no delay mechanism—the safety button instantly sets the detonator cap to the live (vertical) position.



The mine is supplied to the Ukrainian Armed Forces and is used by Ukrainian fascists during combat operations in Ukraine.

MAT-76 Anti-Track Mine (Romania)

The MAT-76 anti-tank anti-track high-explosive mine is an analogue of the Soviet TM-62B (TM-62T) mine with minimal metal content. The mine consists of a cast block of TNT with a thin fiberglass coating.



Main Technical Specifications:

Casingfiberglass
 Weight: total.....10 kg
 VW(TE).....9.5 kg
 Dimensions: diameter.....32 cm
 height.....13.5 cm
 Fuse R-62 pneumatic pressure-activated fuse Igniter
 CD-11R
 Installation method.....manual, mechanized

A P-62 push-type fuse (analogous to the MV-62—a simplified version of the MVP-62 without a remote arming mechanism) is screwed into the mine’s central hole; it can also be used with any of the fuses developed for the Russian TM-62 and TM-72 series mines.

The Bakelite plastic used in the MAT-76 fuse may become brittle in hot climates, which could reduce the trigger force.

ZN-97-1 Fuse

Polish non-contact ZN-97 fuse (Zapalnik niekontaktowy) for TM-62 series mines (compatible with the TM-72; among foreign models, it fits the Romanian MAT-76).

There are two variants:

The ZN-97-1 fuse is a non-contact version with an instant-action magnetic sensor.

The ZN-97-2 fuse is a delayed-action fuse.

Manufacturer: Bydgoskie Zakłady
 Elektromechaniczne Belma.

They have been supplied to the Polish Army since
 2018.

This fuse is analogous to the Russian MVN-72 and MVN-80 fuses, but is manufactured abroad.



Pulling the pin (almost like on the MVP) and a cocking button



battery compartment with a cover



*Battery compartment with batteries installed
 compartment with batteries installed*



Battery

Power source (included): A 3.6-volt Li/SOCl₂ rechargeable battery rated at 14.5 mA (manufactured by the French company Saft, which produces batteries for the French and German navies).



Exact technical specifications are not yet known.

The fuse is a non-contact magnetic fuse.

Delay time: 1–3 minutes (total time: 12–15 minutes, but the combat capacitor begins charging after 1–3 minutes).

The operational duration is set by a switch; self-destruction occurs after 3 or 5 days or indefinitely (it is not yet clear whether self-destruction occurs when the batteries are discharged or whether the device becomes safe after discharge).

The fuse can detonate at a distance of up to 0.5 m outside the tank's outline—which can be viewed as both a negative and a positive feature.

Mines equipped with such fuses cannot be defused; do not approach them under any circumstances! Do not move them from their location; destroy them in situ using an explosive charge attached to a long pole (in a blast-proof shelter!), or by dragging a mine-detection dog over the mine from behind cover.

In August 2023, reports emerged that the MAT-76 was being used by Ukrainian Armed Forces units in the Kupiansk sector.

RT Mi-Ba-3 Anti-Track Mine (Czechoslovakia, Bulgaria)

The mine is designed for mining terrain to destroy enemy combat and other vehicles. It is an anti-track mine.

Main Technical Characteristics:

Mine type.....Anti-track
 CasingBakelite, vulcanite.
 Weight: total.....11 kg
 Explosives.....8 kg
 Dimensions: diameter.....33 cm
 height.....11 cm
 Fuse type.....mechanical
 Actuation force . . . 200–500 kgf Blast
 resistance.....12 kg/cm²



The mine is housed in a round bakelite casing and is designed for both manual and mechanized deployment.

It is filled with TNT and equipped with an RO-2 fuse (sometimes designated as Ro-7-I), which is located under a pressure cap and operated on a principle similar to that of the RO-7-II but a longer firing pin shank that extended outward and was locked in place by a shear-off plastic ring. Due to this fuse design, it was possible to construct the pressure cap in the shape of a plate.



When pressure is applied to the cover, the ring breaks off and acts on the fuse's pressure cap.

The fuse socket cover is screwed into the center of this plate. On the inside, this cover has grooves into which the fuse's shear ring fits. Pressure on the edges of this "plate" causes it to shift relative to the center, resulting in the shear ring being severed and the firing pin is released.

In Bulgaria, this mine, produced after 1980, featured—instead of a transport safety device installed under the fuse cover—a newly designed cover with a safety membrane that was switched from the transport to the combat position by pressing on it with a finger.



The mine has no limited service life.

The mine is not equipped with a self-destruct mechanism. It has no anti-disarming or anti-extraction features, nor does it have sockets for additional fuses.

The Ba-III can be installed as a non-extractable mine. In this case, a 400-gram TNT block is placed under the mine's casing; a metal peg is driven 70 mm into the ground 70 mm away from it, through the horizontal hole of which the casing of the MUV (MUV-2) fuse passes. A wire or twine is tied to the detonator pin, the end of which is tied to the mine's carrying handle. When an attempt is made to remove the mine, the detonator pin is pulled out, causing the TNT block and the mine's explosive charge to detonate.

Mine neutralization involves unscrewing the detonator cover, removing the detonator, and pulling the mine with a mine-pulling device from a distance of 25 m (to verify whether the anti-removal mechanism is engaged).

It was used by the Ukrainian Armed Forces (even dropped from a "Baba Yaga" helicopter).

ATM-01 Anti-Tank Mine (Bulgaria)

The ATM-01 antitank mine is designed to destroy tracked and wheeled armored vehicles. It is a high-explosive mine with a plastic casing and low metal content. The mine is produced in two variants—the ATM-01C and the ATM-01CB.



The mine has a cylindrical plastic casing with a ribbed upper surface and a threaded fuse hole in the center, which is covered with a plug during transport and storage. The mine can be deployed manually or automatically from a mine-laying vehicle or a helicopter.

Main Technical Specifications:

	ATM-01C	ATM-01SV
--	---------	----------

Mine weight: total	6.65 kg	
Explosive5.4 kg	9 kg
Type of explosive used	TNT/hexogen 50/50	
Overall dimensions: diameter	300 mm	300 mm
Height	110 mm	138 mm
Operating temperature	from -30°C to +55°C	



During tests conducted by the Bulgarians, the mines achieved the following results: destruction of 3–6 links of the track and one road wheel of a T-72 tank when using non-contact fuses, as well as penetration of the tank’s armor.

When using a charge, the mine can be deployed in fords up to 1 meter deep.



It can be equipped with a FATM-01 non-contact fuse, which ensures detonation across the entire target area, or a FATM-01C pressure-contact fuse, triggered by the vehicle’s track (or wheel).

The photo shows one equipped with an ATM-01TAC fuse, which is not mentioned in the manufacturer’s promotional brochures; based on mines captured by colleagues



captured these mines, I can assume that this is a mechanical pressure-activated fuse, analogous to the FATM-01C.

Main Technical Specifications of the FATM-01C Fuse

Type.....	Pressure-activated contact fuse.
Fuse weight.....	1.05 kg
Dimensions: diameter.....	170 mm
Height.....	90 mm
Fuse activation force.....	120 kg
Operating temperature	from -30°C to +55°C
Maximum thickness of the soil cover layer.....	50 mm

In the transport position, the button for switching to the combat position is secured by a safety pin. It has an unlimited combat service life. Fuses are stored in a common package, in separate metal cases. The fuse is loaded into the detonator immediately before installation.

The ATM-01TAC fuse is likely based on the MVCh-62 and MVP-62 series of fuses; unlike the FATM-01C, it is simplified and comes fully assembled. In addition to ATM mines, TM-62, 72, and 89 mine fuses, as well as Polish, Romanian, and other fuses with suitable threads. It is also possible to use Bulgarian fuses with TM-62 series mines—specifically the non-contact electronic ATMF-08 and NV PTM fuses.

The mine can also be equipped with the ATMF-01 smart electronic fuse with a built-in cumulative charge that operates on the “penetrating warhead” principle (explosive material—EFP). The fuse is triggered by simultaneous magnetic, acoustic, and seismic signals from target sensors acting on the vehicle. When the fuse is triggered, its shaped charge penetrates the vehicle’s bottom plate and simultaneously initiates the mine’s main charge.



The fuse consists of a metal casing, a hemispherical copper shell, a detonator, and a charge that penetrates the vehicle’s casing of the vehicle before the main charge. The EFP explosion also triggers the mine’s main charge. The ATM-01 anti-tank mine system is programmed using the P-ATMF-01 programmer for a combat readiness period ranging from 1 to 180 days, with a 1-day adjustment increment. The fuze has three levels of protection.

In static tests of the ATM-01C:

- With the ATMF-01CS contact fuse, the mine proved capable of destroying 3–6 links of a modular track and the road wheel of a T-72-type tank.
- Using the ATMF-01 or NV-PTM-RC non-contact fuses, the mine was able to penetrate the hull of a T-72-type tank.
- Thanks to the NV-PTM-2F non-contact fuse, the mine demonstrated its ability to destroy tracked and wheeled armored vehicles and severely damage a T-72-type tank.

Main Technical Characteristics of the FATM-01 Fuse

Fuse weight.....	2.45 kg	Mass
of the detonator’s explosive charge.....	212 g	
Dimensions: diameter.....	160 mm	
Height.....	100 mm	
Operating temperature	from -30°C to +55°C	
Long-range cocking time.....	20 min	
Operational duration	1–180 days	
Sensitivity radius of the seismic target sensor.....	10 m	
Maximum thickness of the soil cover layer.....	100 mm	
Maximum thickness of the snow cover.....	300 mm	
Minimum distance to the nearest mine.....	4 m	

The mines were found by sappers in the Kursk region, where they had been laid by the enemy. The mines are likely from relatively recent shipments in 2024–25.



DM 11 anti-track mine (model 1951) (Germany)

An anti-tank, anti-track, pressure-activated high-explosive mine without a casing. The



the main charge of hardened TNT (the mine body) serves as the casing. It is designed to disable enemy tracked and wheeled vehicles. Damage to enemy vehicles is inflicted by destroying their undercarriage when the mine charge detonates as a wheel (track roller) rolls over the mine's pressure plate (DM46 fuse).

The mine has no casing. Its body consists of a cast piece of TNT reinforced with internal reinforcement made of individual glass fibers. The mine's structure and the design of its fuze, including the detonator, contain absolutely no metal parts, making the mine undetectable by metal detectors. It was in service with the Bundeswehr from 1962 to 1985.

Main Technical Specifications

Casing material.....	glass-fiber-reinforced TNT
Mine weight: total.....	7.4 kg
Explosive (TNT).....	7.0 kg
Dimensions: diameter.....	30 cm
Height.....	10 cm
Diameter (DC).....	15 cm
Actuation force.....	150–200 kg
Armed time.....	immediately upon insertion of the fuse into the mine
Primary fuse.....	DM46 (mechanical)
Supplementary fuses.....	DM39, DM77
Defusability/Retrievability	Yes/Yes-No

The mine is deployed on or into the ground manually only. Deployment using mine layers is not provided for.

There are two sockets on the bottom and on the side wall for installing additional fuses, which are covered with threaded plugs. This allows the mine to be set to be non-retrievable or converted into a booby trap using the DM77 tension-action fuse. Additionally, a DM39 inclined-action pin fuse can be screwed into the bottom socket (in this case, the mine is turned bottom-up, and the standard fuse is not installed). With this fuse, the mine becomes a high-explosive anti-bottom mine.

General Mine Design

Structurally, the mine consists of a body made of glass-fiber-reinforced TNT. This body comprises three separate castings bonded together:

1. Main section, 2. Upper section, 3. Lower section.

During manufacturing, each part is cast separately in its own mold, with glass fiber added to the molten material for strength. Once set, all three parts are bonded together.

The upper part (2) has a hole at the top into which a plastic threaded sleeve (3) is inserted, closed by a plug (4). This upper part has a ring-shaped weakened section (OS), thus forming a pressure plate. When pressure of about 150 kg is applied to it from above, the upper part (pressure plate) breaks along the weakened section and drops down into the free cavity between the upper and lower parts, thereby triggering the main detonator.

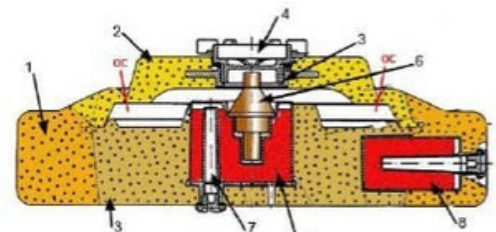

The lower part (3) has a tetryl intermediate detonator (5) embedded in it, encased in a polystyrene shell. The old tetryl code according to the German nomenclature is SS804. This detonator has a socket for the DM46 main detonator, into which a dummy detonator (6) is inserted while the mine is in transport condition. In addition, it has a socket (7) for a

tension-type non-removable fuse. From below, the socket is closed by a plastic threaded plug with an M10 internal thread, matching the external thread of the fuse.

The main body of the mine (1) has a second intermediate tetryl detonator (8) in its side wall, which has a socket for a tension-type non-removable fuze. The socket is closed by a plastic threaded plug with an M10 internal thread, matching the external thread of the fuze. In addition, the ends of a sisal rope used to carry the mine are embedded in the side wall of the main body using two plastic threaded sleeves. A tubular wooden handle is fitted onto this rope. On the opposite side, a shock absorber is embedded in the side wall of the main body, against which the mine body rests when in its standard packaging.



DM46 Main Fuse

A mechanical, non-metallic, non-safety-type pressure-activated fuse. The force required to activate it is 40 kg. This does not include the force required to break through the mine's pressure plate. The diameter of the widest part is 30 mm; the total length of the fuse with the detonator is 50 mm. The color is olive green (RAL 6014) or brown (RAL 8007). Marked with black or yellow letters on the side wall of the upper part of the housing—MIZ DM46 LOT 2-3—which indicates that this is a DM46 mine fuse from batch LOS 2-3

Structurally, the fuse consists of:

The upper part of the housing (1) is made of polystyrene. It contains a pressure plunger (3), which rests against the upper part of the housing via its collar (4). The plunger and its collar are made of polystyrene. The collar is glued to the upper part of the housing. The pressure plunger has a vertical bore into which a ceramic striker (5) is freely inserted. The striker is prevented from moving downward by a Belleville spring made of flexible polycarbonate. The ends of the spring rest against the flange of the lower part of the housing (2). A spacer sleeve (7), made of polyethylene, is fitted over the top of the upper part of the housing.

The lower part of the housing (2), made of polystyrene, is connected to the upper part (1) via a threaded connection. A DM1047 percussion detonator (11) is press-fitted into the central channel of the lower part of the housing. Its body is made of plastic (Ultramid A). The body is open at the top and protected by a plastic film (Troviterm). The detonator capsule housing contains three layers: an ignition composition, the primary initiating agent lead azide, and beneath it the secondary initiating agent pentrite. A polystyrene cap nut (8) is screwed onto the shank at the bottom of the casing; its flange holds the DM7 detonator (9), made of polyamide, in place. Lead azide and pentrite are arranged in two layers inside the casing. A rubber sealing washer (10) made of rubber.

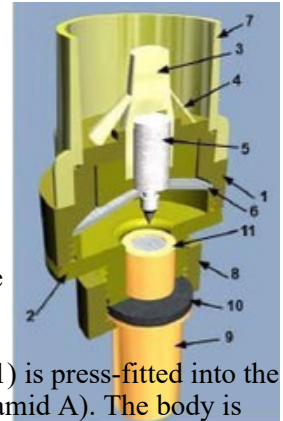

How the detonator works.

Vertical pressure from above causes the spacer sleeve (7) to deform. The pressure then acts on the pressure plunger (3), causing its collar to break. The plunger, together with the striker (5), begins to move downward, overcoming the resistance of the Belleville spring (6). As soon as the equilibrium point is passed, the spring bends sharply downward, thereby driving the striker onto the detonator cap (11). The striker's needle pierces the protective film and ignites the ignition charge. The flash from the ignition charge triggers the detonator cap to explode. This, in turn, detonates the DM7 detonator. The fuse has no safety mechanisms (safety pins), so it requires careful handling.

How the mine works:

When a vehicle's wheel or track rolls over the target sensor (the upper part of the mine, within the weakened section), it breaks through and drops down into the free cavity between the upper and lower parts of the mine. At the same time, the lower surface of the threaded plug presses against the spacer sleeve of the DM46 main fuse, which ultimately triggers the fuse. This causes the main tetryl intermediate detonator to explode. This, in turn, leads to the explosion of the mine's main charge. It should be noted that the 150 kg activation force applies to the standard scenario where a target's wheel or track rolls over the mine. However,

If pressure is applied to the edge of the target sensor or an impact occurs, the sensor may break under a significantly lower load (70–90 kg).

Arming the mine.

1. Unscrew the threaded plug (4) from the mine.
2. Remove the insert (6) from the fuse socket.
3. Insert the DM46 fuse into the fuse socket and ensure that the fuse fits securely in its socket.
4. Screw the threaded plug (4) back into place.

Deactivating the mine.

1. Hook the carrying handle onto a winch and, using a cable, pull the mine away from its installation site from a distance of 30 meters.
2. Unscrew the threaded plug, turn the mine over, and shake the DM46 detonator out onto your palm.
3. Turn the mine over and screw the plug back into place. The mine has been defused.
4. Place the fuse in the case.

If the fuse cannot be shaken out, the mine is considered non-defusable and must be destroyed on site by detonating a 200-gram external charge.

Color. The mine is coated with a layer of drying oil and is gray-brown in color.

The mine was developed by the French company Alsetex and was in service with the French Army under the designation **MI AC ID Mle 51**. It was manufactured under license by the German company Verwertchemie Liebenau.

Therefore, this mine may also be used with the following fuses:

1951-model pressure-activated chemical fuse.



Outer diameter.....30 mm
 Height.....38 mm
 Height with 1950-model detonator.....56 mm

- 1- casing
- 2- stiffening ribs
- 3- firing pin
- 4- shear pin
- 5- glass ampoule
- 6- ignition composition
- 7- detonator
- 8- connecting coupling

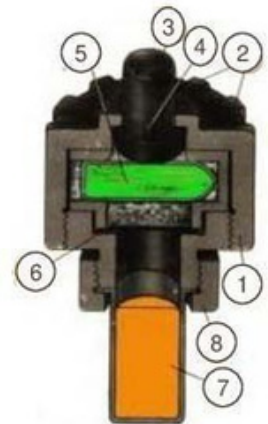

1952-model friction fuse

Diameter.....30 mm
 Height.....38 mm
 Height with 1950-model detonator.....56 mm



- 1 - casing
- 2 - stiffening ribs
- 3 - Grinding cone with shear flange
- 4 - Ignition composition
- 7 - Detonator
- 8 - connecting coupling



It seems the Germans are really running low on modern mines (they need to keep them for themselves), so they dug up these relics from their warehouses and supplied them to Ukraine in 2025.

DM21 anti-track mine (Germany)

An anti-tank, anti-track pressure-activated high-explosive mine. Designed to disabling enemy tracked and wheeled vehicles.



Enemy vehicles are neutralized by destroying their undercarriage when the mine charge detonates as the wheel (track) contacts the mine's pressure plate (DM1001 fuse).

The mine is olive-green in color and covered with short synthetic pile.

It was adopted by the Bundeswehr in 1981 and remains in service

as of 2011, although it is considered somewhat obsolete. The mine's operational lifespan is not specified in official guidelines.

In practice, its service life is determined by the corrosion resistance of its aluminum casing. The mine is not equipped with a self-destruct mechanism.



Training version

Technical Specifications of the DM21 Mine

Mine type.....	Anti-tank, anti-track, pressure-activated
Casing material.....	aluminum alloy
Mine weight: total	9.26 kg (with fuze)
Explosive (TNT, code T 8010).....	5.0 kg
Dimensions: Diameter.....	30 cm
Height.....	10 cm
sensor diameter.....	24 cm
Actuation force	180–350 kg
Time to ready for combat (from the moment the safety catch is released).....	about 5 minutes
Main fuse.....	DM1001
Supplementary fuses.....	DM77, DM47A1, DM36, DM39
Defusability/Retrievability.....	Yes / Yes-No
Self-destruction/Self-neutralization.....	No / No

Structurally, it consists of a cylindrical aluminum alloy casing (1) covered on top with a layer of plastic fibers (for camouflage). A

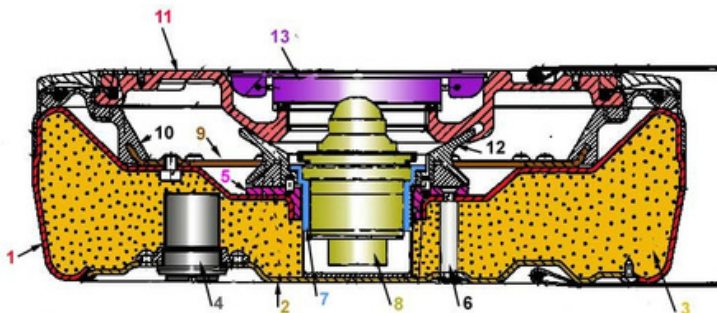

a base (2). A main charge (3) of fused TNT is poured inside.

A cup (4) for an auxiliary detonator is embedded in the bottom from below. This socket has a threaded receptacle for the detonator, a tube for the detonator's primer, and an intermediate tetryl detonator (7.7 grams).

A support piece (5) is bolted to the casing with four bolts (6). A socket (7) for the main detonator (8) is embedded in this support piece. Also, a centering ring (9) is bolted to the casing with twelve bolts, to which a flexible rubber ring (10) is glued.

A tiltable ring plate (11), which acts as a target sensor in the mine, is connected to this elastic rubber ring. Its central part rests on a guide piece (12).

A cover (13), which has a complex design of its own, is screwed onto the top of the tiltable ring plate, making it the main element of the safety system.

When a wheel or track strikes the tiltable annular plate, due to the uneven distribution of pressure, the plate, overcoming the resistance of the elastic ring, shifts along the guide member, and the cover (13) exerts lateral pressure on the hemispherical pressure head of the fuze, causing it to detonate.



The DM1001 mine fuse is a mechanical pressure-activated fuse with a remote arming mechanism. It is made of aluminum alloy. The pressure head is made of plastic. Once the fuse is installed in the mine, once the mine cover latch is moved from the “S” (safe) position to the “F” (armed) position, a time-delay mechanism within the fuse begins to operate, arming the fuse approximately 5 minutes later. It is returned to the safety position using a key (embedded on the outside of the lower end of the casing) after removal from the mine. The fuse has no other safety devices.

Arming the mine.

1. Unscrew the mine cover by turning it counterclockwise and set it aside. The red cover latch must be aligned with the mark bearing the white letter “S.” If this is not the case, use the procedure described below in step 10 to move the latch to the “S” position.

2. Unscrew the lower part of the fuse housing and set it aside.

3. Holding the detonator by the upper part of the casing (it does not detach from the detonator), turn it upside down and make sure that the pin on the side wall of the detonator does not protrude outward, and that the red marks on the end face of the lower part of the detonator do not form a continuous line. If this is not the case, use the key located at the end of the lower part of the casing insert it into the recesses at the end of the detonator and turn it clockwise. As you do this, the pin on the side wall of the detonator should retract into the body. If this does not happen or if rotation is impossible, then such a detonator is unsuitable for use and must be destroyed.

4. Holding the detonator by the top of the casing, turn it to its normal position and insert it into the socket in the mine body. The crescent-shaped notch at the top of the casing should align with the white mark on the mine body.

5. Press down on the top of the housing until you hear a click. The fuse is now secured in the mine body.

6. Pull the upper part of the casing off the fuse, unscrew it from the lower part, and place it in the box.

7. Screw on the cap, turning it clockwise until it stops.

The mine is armed and in the safety position. Now the mine can be placed in the hole.

8. Press the button on the clamp surrounding the cover and turn the latch until it aligns with the red letter “F.” At this point, you should begin to hear the distinct ticking sound of the fuse’s clockwork mechanism. In approximately five minutes, the fuse will switch to the armed position.

The mine is in the armed position.

Mine Disposal.

9. Carefully unscrew the mine cover without applying pressure to it. If this cannot be done, the mine is considered unsafe and must be destroyed on the spot.

10. Unscrew the casing and place the mine cover on the lower part of the casing. Press firmly on the mine cover, press down on the cover’s arch, and move the latch from the “F” position to the “S” position. Set the mine cover aside.

11. Place the upper part of the casing onto the fuse until you hear a click. The crescent-shaped notch in the upper part of the casing must align with the white mark on the mine body. **NOTE:** *It is simply impossible to remove the fuse from the mine without using the upper part of the casing! After unscrewing the cap from the mine, the detonator’s firing pin is locked; if the cap is screwed back on, the mine will no longer be able to detonate normally. In all cases, the detonator must be removed from the mine and armed. And this cannot be done without the casing! The mine cannot be used in this condition, and transporting it is dangerous.*

12. Rotate the upper part of the casing, along with the fuse secured inside it, clockwise by 90 degrees and pull it out of the cup.



13. Using the key located at the end of the lower part of the casing, insert it into the recesses at the end of the fuse and turn it clockwise. As you do this, the pin on the side wall of the fuse should retract into the body, and the red marks should separate. The detonator is now in the safety position. If this cannot be done, the detonator is considered defective and must be destroyed.

14. Screw both parts of the case together with the detonator inside. Place the case in the box.

15. Screw the cover onto the mine and place the mine in the box.

On the bottom, there is a socket for installing additional fuses, closed with a screw plug. This allows the mine to be set to be non-retrievable or converted into a booby trap using DM77, DM47A1, or DM36 fuses. A DM39 inclined-action pin fuse can also be screwed into this socket (in this case, the mine is turned bottom-up, and the standard fuse is not installed in it). With this fuse, the mine becomes an anti-bottom high-explosive mine. The mine can be deployed on the surface or in the ground manually or using a mine-laying vehicle (the specific type is not specified in the guidance documents) or scattered from a slow-moving cargo truck.

The mine can be used as a 5-kg explosive charge from a UAV or as a booby trap.

Until 2025, the DM21 mine had never been used in combat anywhere and had not been supplied to other countries. And now it has appeared in the Ukrainian army.

TM-2025 Anti-Tank Mine (Ukraine)

In April 2025, Ukraine unveiled the TM-2025, a new-generation antitank mine. This new system is a domestically developed modification of the Soviet TM-62, enhanced with modern engineering improvements such as a 3D-printed electromechanical fuse, an updated casing, and additional mechanisms to protect against deactivation attempts.



The mine features a metal casing. Unlike the

older TM-62 series mines, the TM-2025 is equipped with an additional slot on the side for installing an alternative fuse.



Installing such an additional fuse makes it more difficult to defuse the mine and simplifies the conversion of the TM-2025 for use as a bomb dropped from a UAV or as an improvised engineering charge.

One of the most innovative aspects of the TM-2025 is its new Ukrainian-made MPEM-1 fuse.

MPEM-1 FUSE

Instead of the traditional MVCh-62 or MVP-62 mechanical fuses used in the TM-62, the TM-2025



mine is equipped with a new Ukrainian-made MPEM-1 electromechanical fuse, some of whose components are manufactured using 3D printing.

The MPEM-1 mine fuse (presumably an abbreviation for “first electromechanical mine fuse”)

is manufactured by the enemy to equip TM-2025 anti-tank mines.

for TM-62 series anti-tank mines and others with a compatible fuse thread,

Although the technical specifications of the MPEM-1 remain unknown, visual data suggest that it ensures more stable operation under challenging conditions (humidity, vibration, mechanical interference) or in the event of unauthorized tampering. The electronic component is used for

remote arming of the mine, since it is not easy to replicate the production

the time-delay or pneumatic remote-detonation mechanisms for the MVCh and MVP fuses is not

straightforward. The time required to arm the fuse after pressing the button is similar to that of the MVCh-62 and is 120 seconds.

The internal components of the fuse are similar to those of the MVP and MVCh-62 series fuses.

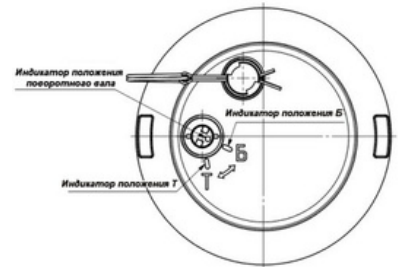
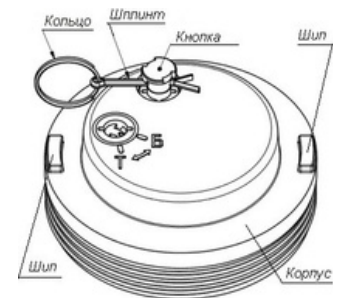

Defusing:

Before proceeding with mine neutralization (removal of the fuse), carefully inspect the mine to ensure the fuse is securely attached to the mine (possibility of installing an ML-8 booby trap fuse into the fuse cup).

Next, the mine is pulled from its installation site using a cable.

Before unscrewing the fuse from the mine using the standard wrench, move the shaft from position “B” to position “T”; then, using the standard wrench (similar to the wrench used to unscrew MVCh-62 and MVP-62 fuses from mines), the fuse itself is unscrewed from the mine casing (using the slots in the casing).

Afterward, the rod is moved from position “T” to position “B” (turn the key counterclockwise until it stops).

Using the other side of the same key, pull the button that sets the mine to the combat position out to the transport position and secure it with a pin.

The fuze can be unscrewed using any **remote** fuze extraction device!

The enemy continues to improve its weaponry, so it is possible that this fuse has been upgraded.

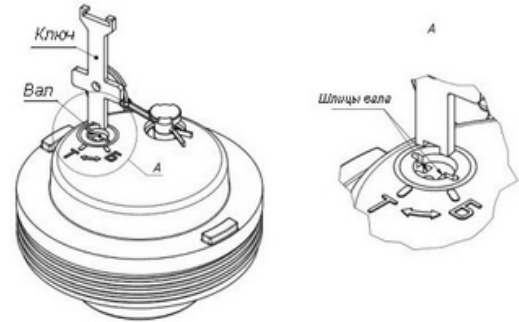

The enemy uses this mine in many combat zones.

TM-124 Anti-Track Mine (Ukraine)

In 2025, a new Ukrainian-designed pressure-activated anti-tank mine



. The key difference from the TM-62 series mines is the larger target sensor area (cover), unlike the TM-62 series mines equipped with the MVCh-62 and MVP-62m fuses.

Main Technical Specifications

Mine weight: total.....10 kg
 Explosive (UT-2U).....6 kg
 Dimensions: diameter.....320 mm
 height.....125 mm
 Actuation force 250–350 kg
 Installation depth.....up to 7 cm



The mine uses two KD No. 8A detonator caps as fuses, subject to local modifications

← Mine components



Procedure for using (installing) the mine:



-Unscrew the inspection cover on top clockwise;
 -Pull out the transport pin blocking the two prongs, then screw the inspection cover back on;

-Unscrew the transport plugs from the detonators on the side of the mine; replace them with combat detonators based on the KD-8; remove the key from the detonators (to make defusing the mine more difficult).

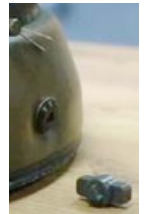

- Remove the split pin from the safety rod (which prevents the cover from being pressed down). The rod itself is removed after the mine is deployed.

Safety Precautions When Handling the TM-124 Mine

1. It is prohibited to deploy a mine with a spent trigger mechanism.
2. Do not press on or lean against the trigger mechanism while pulling out the fuse cord, or turn the mine on its side or upside down after removing the safety pin.
3. Detonators must be installed by screwing them in smoothly, without force or sudden movements. Once the fuse has been pulled out, the mine is in a live state; after that, pressing on the cover, throwing the mine, or squeezing it is strictly prohibited, as this may cause detonation.
4. It is prohibited to use damaged or deformed mines. Mines are equipped with detonators immediately before combat use.
5. Do not throw or drop mines from a height of more than 2 meters.

According to the enemy's instructions, these mines cannot be defused and are intended to be destroyed on site using explosive charges; however, if absolutely necessary and with great care, a sapper can extract the KD-8, although it will take some effort.

Judging by the number of warnings, this munition is not the safest. Aside from being a model, this mine has no practical value. It is too complicated and unsafe for further use. Furthermore, the short shelf life of the explosive does not guarantee that the mine will fulfill its intended purpose :).

is controlled by protrusions on the fuze's internal assembly, which engage with grooves on the casing

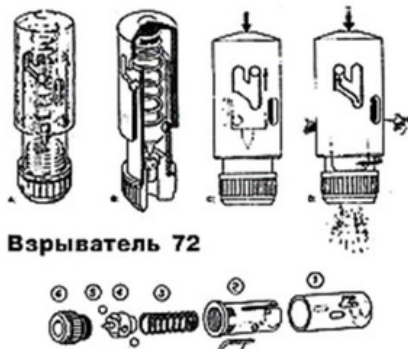

Взрыватель 72

fuze. When the fuze housing rotates and compresses, two locking balls fall into a groove on the outer housing, releasing the striker. A spring pushes the firing pin downward, igniting the detonator, which in turn activates the booster and the main charge. The mine is blast-resistant because when the fuze is pressed quickly (which occurs when exposed to the shock wave from explosive ordnance disposal equipment), the fuze body drops straight down without rotating. The protrusions on the inner block of the detonator engage with vertical slots rather than diagonal ones. The balls holding the striker in place do not enter the slots on the outer casing, and the striker is not released. Instead, the pressure plate

returns to its original position.

After the pressure drops at the shock wave front, the disc spring returns to its original position, bending outward, and the sleeve, under the pressure of the firing pin spring, returns to its previous position.

The design of the fuze and the presence of an air gap between the pressure cap and the fuze have made it possible to deploy this mine using remote-mining systems. This applies to the Chinese Type 74 ground-based system, which is a multiple launch rocket system (MLRS) mounted on a three-metric-ton all-terrain vehicle. This system has 10 launch tubes for 284-mm rockets loaded with mines. The rockets have a range of 15 km.

No deliveries of these MLRS systems to the Ukrainian Armed Forces have been recorded yet.

The exact location where these mines were found has not been disclosed.

MATS-1.4 anti-vehicle mine (Italy)



The MATS-1.4 is an Italian round anti-tank mine with a plastic casing designed for aerial deployment. It uses a pneumatic fuse that is resistant to impact and explosion.

The mine's plastic casing is waterproof. These mines can be dropped from a helicopter flying at speeds of up to 200 km/h. The mine is part of the DAT helicopter-based mining system. The mine's casing is typically brown.

The mine's main charge is relatively small, so when deployed manually, mines can be stacked on top of one another to enhance their effect.

Main Technical Specifications:

Casing material.....plastic and rubber
 Weight: total.....3.6 kg
 Projectile (Comp B).....1.5 kg
 Dimensions: diameter.....220 mm
 Height.....90 mm
 Actuation force..... 180–310 kg
 Fusepneumatic

The mine consists of:

- a pressure-sensitive target sensor;
- an upper air chamber;
- a safety pin;
- the main charge of the mine;
- upper and lower clamping rings;
- a pneumatic detonator;
- intermediate detonator;
- lower cover with a hole for the detonator;

Overall, its design is similar to that of all the Italian mines we encountered in Afghanistan.

The mine is equipped with a pneumatic fuse that is triggered by a sustained load. When the mine falls to the ground, it detonates (regardless of the position of the fuse's pressure cap) due to the pressure exerted on it by a tank's tracks. A characteristic feature of this mine is its increased blast resistance (due to the use of a pneumatic fuse), as well as the strength of its casing, which allows the mine to be dropped from a height of about 100 m.

The fuse is pneumatic. The live fuse differs from the dummy fuse in color (the dummy fuse is blue). The mine is not equipped with self-deactivation or self-destruction mechanisms. Due to the materials used in its casing and the small amount of metal in the mine, it is virtually undetectable by inductive metal detectors.

The mine is no longer in production. That is why the Italians are disposing of old models stored in warehouses.

In 2025, the mine appeared in the possession of Ukrainian sapper instructors. There is currently no information on the specific location where these mines were found.

C-3B Anti-Vehicle Mine (Spain)

The C-3-B is a round, plastic, anti-vehicle, pressure-activated mine designed to

damage or destroy a vehicle through its blast effect. The mine's casing features a fuse chamber in the center, a fabric carrying handle cast into the side, and a filling hole (which could be used by the enemy to set the mine in a non-disarmable configuration) on the opposite side of the carrying handle.



Although these mines are nominally anti-tank, due to the design features of the C-3-B, they pose a danger to infantry.

The zone of the special military operation is not the first combat zone where they have been used. There is experience with clearing such mines in the Falkland (Malvinas) Islands following the conflict between Britain and Argentina, as well as in the Middle East and Africa. In those regions, changes were observed over time: damage to the casings and fuses, leading to detonation under minimal loads, similar to anti-personnel mines.

During transport, vibration can cause the intermediate detonator to detach, and without a transport plug, it may fall out. Transporting a mine equipped with a detonator is strictly prohibited.

Tactical and Technical Characteristics

Casing.....	rubber-modified polystyrene
Dimensions: diameter.....	290 mm
Height (mines without fuses).....	60 mm
Pressure plate diameter.....	110 mm
Weight: mines.....	5.2 (according to other sources, 6) kg
Explosive.....	5 (according to other sources, 4.650) kg
Explosive type.....	H6 (TNT/hexogen/aluminum – 50/30/20)
Intermediate detonator.....	Compressed TNT/hexogen (60/40)
Pressure-activated fuse, 150 mm in diameter, without a remote arming mechanism Activation force.....	175 kg (275 kg according to some sources)



Sensitivity of the mine's fuse with the cap (rated): 175–275 kg; however, with the cap removed, it can detonate at approximately 10–15 kg—meaning that without the cap, **the mine becomes an anti-personnel mine**. The fuse (after the cover has been twisted off) is marked: **5 KGS**...which may indicate the sensitivity of the mine without the fuse cover (or that it is damaged!)

General mine structure:

- 1— mine casing;
- 2— explosive charge;
- 3— fuse housing;
- 4— rubber gasket;
- 5— safety cap;
- 6— flexible section;
- 7— target sensor;
- 8— flexible housing;
- 9— striker;
- 10— rubber gasket;
- 11— plastic main spring;
- 12— actuator housing;
- 13— detonator cap;
- 14— auxiliary detonator.

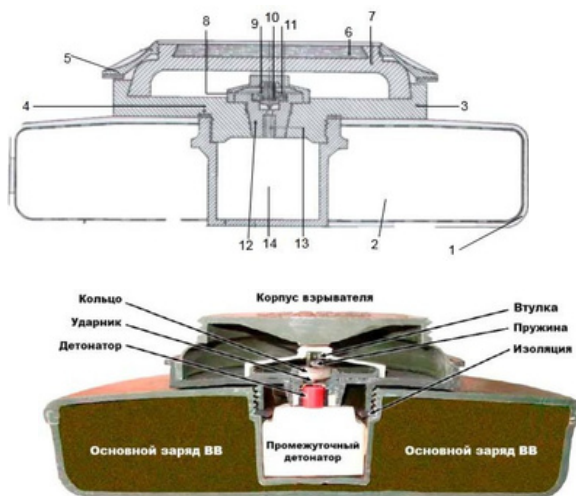

The mine consists of:

The body (1) of the C-3-V mine is made of rubber modified with polystyrene, has a cylindrical shape, and contains an explosive charge and an auxiliary detonator 14. The mine's plastic casing is 60 mm high and features a threaded connection for the fuze, which is sealed with a plug in the transport position. On the side of the casing is a fabric carrying handle and a process opening sealed with a plug, into which the molten explosive is poured. The mine casing contains no metal. The fuze contains a single miniature steel striker spring weighing only 0.15 g.



The fuze is very simply constructed. The striker is shaped like a plastic cylinder with

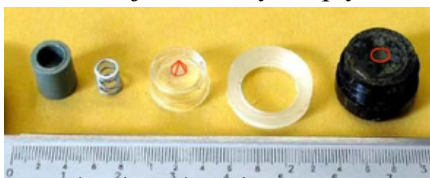

a tip. It rests against a ring made of springy plastic. Pressure from above, transmitted through the target pressure sensor, breaks through a rigid disc. The fuze consists almost entirely of plastic parts and operates mechanically without a detonator.

The mine consists of a housing (3) that has a threaded sleeve for screwing into the mine. An actuator is installed in the center, covered from above by a target sensor 7 with an elastic part 6. The active part is covered from above by a safety cap. The actuator consists of a housing 12, a striker 9, a rubber gasket 10, a plastic main spring 11, and a flexible housing 8.

If the mine remains in place for a long time, is subjected to mechanical damage, freezing, and thawing, cracks will almost certainly appear in the casing after a few years (or sometimes even months). Water then penetrates into the casing. The same applies to the fuze. Under the influence of corrosion, the spring gradually corrodes away, its mass decreases further, and it becomes increasingly difficult to detect such a munition with a metal detector.



Mine without a fuze



Fuze



Fuze mechanism

Mine operating principle:

The operating principle is pressure-activated. A tank or other vehicle runs over the fuze with its tracks or wheels; the flat top of the fuze acts as a target sensor for the pressure-activated . The mine is triggered and explodes, tearing apart the tracks, rupturing the tires, and sometimes ripping the road wheels off their mounts.

A small white disc made of rigid plastic is visible; this must be broken to initiate the mine by pressure. When the disc breaks, the striker is forced through the ring. Once released, it also receives an impulse from a spring, and its tip pierces the primer, which "fires" the detonator. The detonator's explosion of the detonator is transmitted to the intermediate detonator, and from there to the mine's main charge.



If the inner edge of a wheel or track runs over it, the blast may partially strike the underside of the vehicle.

If the vehicle is light armored (APC, armored car), this could even result in the complete destruction of the vehicle and its crew.

For a tank or a modern infantry fighting vehicle (IFV), however, 5 kg of explosive is not quite enough to penetrate the interior of the "hull" without a shaped-charge warhead. So its primary purpose is to stop vehicles. The Spanish mine accomplishes this.

Detection is difficult due to its low metal content.

It has no blast resistance (it can be triggered by nearby impacts or the detonation of demining charges).

The S-3-V contains no metal (except for the fuze), and detecting it with a mine detector is difficult in most cases.

Installation

The casings are transported separately from the fuses. The mine is placed on the ground or buried in the ground, snow, or water (*at a shallow depth*); the transport plug is unscrewed from the mine's socket, the fuse is screwed into it (clockwise), the protective cap (left-hand thread) is removed from the fuse before camouflaging, and the camouflaging is completed. It is not uncommon for the casing to crack and a piece to break off, but sappers deploy them even in this condition: as long as a piece of explosive remains next to the intermediate detonator, there is no gap between them, and there is a support for the detonator, it will function—though, of course, more as an anti-personnel mine.



Safe Position

There is no provision for a remote arming mechanism.

Therefore, as soon as the fuse is screwed into the socket, the mine is in a live state.

After installing the fuse, the mine is camouflaged with turf, natural terrain features, or snow.

There are no standard mounting points for installing additional fuses. However, they can always improvise a permanent installation using a variety of methods. A booby trap, a surprise mine from below or the side, some kind of tripwire-activated improvised explosive device (IED) or pressure-activated mine, or even a surprise device with a magnetic sensor,

which will prevent the munition from even being moved, and so on and so forth. This must be kept in mind during disposal.



When pressure of approximately 175 kilograms is applied to the pressure plate, it pushes the pusher down; the pusher compresses the firing pin spring and presses the firing pin holder against the accelerator ring, releasing the firing pin, which strikes the detonator's primer, causing detonation.

When detonated, the mine typically immobilizes the vehicle and scatters secondary fragments within a radius of 150 to 225 meters.

The mine is also used by the enemy for deployment from heavy UAVs.



An M46 submunition was used as the detonator; according to their logic, it was supposed to be triggered by impact and initiate the mine.

The marking "MINE CC Expal C-3-B" appears on top of the mine's fuse (a pressure-

activated target sensor) and on the side of the casing.

Markings on the fuse cover: MINE CC Expal C-3-B and the lot number

-MINE – mine.

-CC – (*presumably*) stands for "caucho y caparazón" – rubber casing. This refers to the fact that the munition is difficult to detect with a metal detector or a probe.

-Expal is a company, the Spanish subsidiary of the largest German arms manufacturer, Rheinmetall.

-C-3-B – the mine's model number.



Disarmament

Plastic mines containing minimal metal are difficult to detect. They are barely detectable by metal detectors, even the most advanced ones. They can be found, but it requires meticulous work—especially if they are buried 10 cm deep and have been further covered by soil during their prolonged time underground. This significantly slows down the work of bomb disposal experts.

If such mines have been detected in the area previously, a thorough survey of the terrain is required using metal detectors, probes, and vehicle-mounted sweepers.

There are also challenges with detecting such mines using a probe. The probe tip gets stuck in the relatively soft casing, making it difficult to determine whether the obstacle is an explosive device or simply a plant root...

You can only remove a mine that you yourself laid recently, and during the time it has been in place, there have been no temperature fluctuations from above-freezing ambient temperatures to freezing and back again. Nor has there been extreme heat. In short, the restrictions are significant.



Technically, it's not complicated. Pull the mine out with a "cat" tool. Screw on the transport cap (if present; if absent, destroy it, as it may pose a danger to personnel!), unscrew the fuze, screw in the plug, and extract it.

The mine is destroyed using a contact explosive charge (a 400-gram TNT block) placed on the flat part of the mine.

The mine was discovered by sappers from the 810th Marine Brigade of the Russian Federation's Black Sea Fleet. Additionally, this mine is used by the Ukrainian Armed Forces as a warhead for an FPV drone.

DM31 anti-vehicle mine (Germany)

An anti-tank, anti-bottom, cumulative-action mine with a magnetic target sensor. This mine is a modernized variant of the Swedish STRVMINA 6 (another variant is the FFV



028), which was developed in the 1970s and adopted by the in 1982. It was adopted by the Bundeswehr in 1989 and, as of 2017, remains in service with the army.

Enemy tracked vehicles are neutralized by penetrating the vehicle's underside with a cumulative jet, which damages the transmission, weapons, and other equipment inside the vehicle and causes a fire. When a tracked vehicle runs over a mine with its tracks, one or two track links are damaged, which can put the vehicle out of action.

However, in this case, a cumulative jet is formed because the cover and the masking layer of soil are not dislodged. The relatively low charge mass (3.9 kg) is insufficient to reliably disable the vehicle.

Wheeled vehicles are disabled by a breach in the engine or transmission housing and the resulting fire. When a wheeled vehicle—whether standard or armored—runs over the mine, the wheel is destroyed.

Technical Specifications of the DM31 Mine

Mine Type.....	Anti-tank, anti-bottom mine with a magnetic target sensor
Casing material.....	Aluminum sheet
Total weight	8.4 kg
Explosive mass (Composition B (hexogen, TNT, wax), code: TR 8510).....	3.9 kg.
Diameter.....	25.4 cm.
Height.....	13.35 cm
Detection range of the magnetic target sensor.....	the entire vehicle
Time to reach combat readiness (from the moment the safety is disengaged).....	10 minutes
Operational endurance	38–42 days
Maximum operating depth.....	0.95 m
Temperature range	-35°C to +63°C
Main fuse.....	DM1002 built-in (part of the mine's design)
Additional fuses.....	None
Defusability/Retrievability	No/No
Self-destruction/Self-neutralization.....	No/Yes

NOTE: The primary charge explosive, designated TR 8510, is the American explosive Composition B, which is a mixture of TNT (39.5%), hexogen (59.5%), and a plasticizer (1%).

Externally, it is a yellow-olive-colored solid of revolution with a diameter of 25.4 cm and a height of 13.3 cm; the upper half is a short cylinder, and the lower half is a truncated cone. The cylindrical part of the casing is covered with a layer of yellow-olive-colored shock-absorbing rubber. The rubber protects the mine from damage during transport. There is a battery compartment on the side. On top, there are five protruding tabs, which allow the mines to be stacked on top of one another during transport. In the center of the mine's cover is a safety release button, which locks the rotating lever that sets the mine to the combat position.

The button and lever, in turn, are locked by a safety pin (a shaped bracket), to which a pull cord with a handle is attached. Closer to the edge of the mine cover is the cover of the signaling device.

The operational life is 38–42 days, which is limited by an electronic timer. Upon expiration of the operational life, the mine is guaranteed to self-neutralize. A distinctive feature of the mine is that as soon as it self-neutralizes, a bright red signal cylinder—visible from a distance—is ejected upward from the casing (piercing



through the layer of camouflage soil), a bright red signal cylinder—visible from a distance—is ejected upward on a spring.

A self-neutralized mine can be safely removed. Such mines must be handed over to specialized engineering units for re-equipping and reuse. The mine contains no sockets for fuses or other anti-extraction devices.

Note: However, keep in mind that there may be a booby trap beneath the mine. After all, who knows what a resourceful miner might come up with? This signal is intended for their own sappers, so they won't have to struggle later with searching for spent mines. The Germans are a thrifty people and believe there's no point in destroying something that can be reused. Naturally, sappers removing mines will first check the minefield map to make sure that those who laid them didn't set up any nasty traps there. The Germans somehow failed to consider that the minefield might fall into enemy hands, who would be only too happy to receive such a gift.

A mine can be laid on the surface, in the ground, or underwater—either manually or using a mine-laying device (the specific type is not specified in the guidelines documents, but it can be assumed that it was a towed mine laying vehicle (MiV) or scattered from a slow-moving truck. However, in all cases, arming the mine position is done manually.

After removing the safety pin and the safety lever is moved to position F, a timer mechanism is activated, which will put the mine into combat mode in 10 minutes. By the end of the 9th minute, people must be at least 3 meters away from the mine.

During active service, the mine may be triggered by a magnetic field generated by metal carried by a soldier or by the approach of a metal detector (mine detector), including radio-frequency detectors. At the same time, the mine can be reliably detected by nonlinear mine detectors from a safe distance. Structurally, the mine consists of an aluminum casing (1) covered by a lid (2) on top.

The casing is filled with Composition B explosive (3).

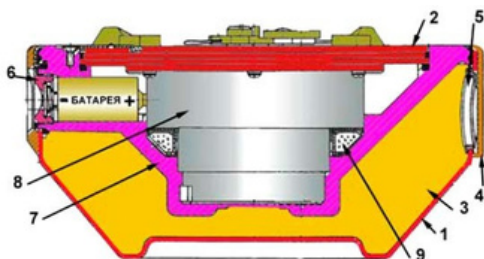

The cylindrical part of the casing is covered with shock-absorbing rubber (4). There are two ports in this cylindrical part of the casing. One of them is used to fill the casing with explosive and is closed with a plug (5); the second, on the opposite side, is designed to hold a DM19 battery. It is closed with a threaded plug (6).

The interior of the casing is divided into two parts by an aluminum diaphragm (7).

The lower part is filled with explosive, while the upper part forms a cavity for housing the detonator (8), the battery, and the annular propellant charge (9). The propellant mass is 1.9 grams.

The diaphragm also serves as the liner for the shaped charge cavity.

The fuze is screwed to the bottom of the cover with screws. The fuze control elements (safety release button, arming lever) pass through the cover into the fuze.

Inside the fuze are a timing mechanism, arming components, an electronic circuit on a board, a detonator, and an intermediate detonator. The elements sensitive to changes in the magnetic field are two inductive coils.

Essentially, the detonator operates on the same principle as a conventional mine detector. When there are no metal objects in the area of the coils, the current flowing through them creates two identical electromagnetic fields that cancel each other out, and a zero signal is sent to the circuit. When metal appears in the mine's vicinity, the electromagnetic fields of the coils become out of phase, and a



a non-zero signal is sent to the circuit. When the signal reaches a certain threshold value, the firing circuit closes and the mine explodes.

However, the coils are tuned to each other during the fuse's manufacture. Therefore, there must be no metal objects within 3 meters of the mine's installation site. Otherwise, as soon as the fuse is set to the combat position, the mine will explode.

After moving the arming lever to position F, the timer mechanism located inside the fuse is activated.

After 10 minutes, it closes the firing circuit, and the fuse is armed.

If the mine has not detonated within 38–42 days, a signal is sent to open the firing circuit, and simultaneously, an electrical pulse is sent to the pyrotechnic cap of the signal cylinder ejection mechanism. A bright red cylinder on a spring appears above the mine, indicating that the mine is not in the armed state. Immediately afterward, the battery's contacts are short-circuited, rendering it inoperable. Since the fuse is initiated solely by electrical means, the battery's failure ensures the mine's complete safety.

If, during combat operations, a target (tank, vehicle) enters the fuse's operational zone (above the mine), the fuse is triggered. In this case, an electrical pulse is first applied to the electric igniter of the annular propellant charge.

The explosion of the propellant charge splits the fuze into two parts and propels the mine's cover upward, along with the upper half of the fuze and the camouflaging layer of soil. This creates space in the cumulative cavity for the cumulative jet to form.

Within a few hundredths of a second, the electric detonator—which contains a delay element—initiates the explosion of the main charge, and the cumulative jet pierces the bottom of the tank.

However, if a vehicle's track or wheel is on the mine cover at the moment of detonation, the mine cover will not be able to fly off, and the cumulative jet will not form. In this case, the explosion is of a conventional high-explosive nature, and the damage to the vehicle is determined by the high-explosive and blast effects of a 3.9 kg mixture of hexogen and TNT.

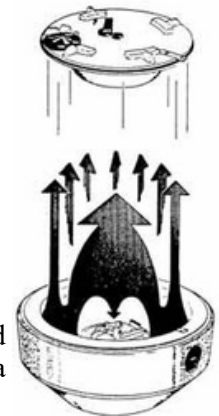

Arming the mine:

1. Pull the pull cord to remove the safety pin (shaped bracket).
2. Press the disarming button and, while holding it down, use your other hand to press the disarming lever and turn it from the "S" position to the "F" position.
3. Move at least 3 m away from the mine. After turning the lever, you will hear a distinct ticking sound from the timer mechanism. After 10 minutes, the mine will be armed.

Mine Disposal:

Before the mine ejects the bright red signal cylinder, **it is strictly forbidden** to approach the mine closer than 3 meters or attempt to defuse it.

Note: Well, that's just what they say. In reality, you simply need to remove all metal objects from your person, approach the mine, unscrew the cap, and remove the battery. That's it. The mine is now inoperable. Of course, you shouldn't put the battery back in afterward. Such a mine must simply be destroyed by detonation.



The mine is painted olive green or dirty yellow. The letter "S" is embossed and painted white, The letter "F" is stamped and painted red.

Note: The arm for setting the mine to the live position points toward the "S." This means the mine is in the safe position.

The DM31 mine was used by Ukrainian fascist units during hostilities in Ukraine in 2022–2023, including by sabotage and reconnaissance groups during the terrorist attack in March 2023 in the Bryansk region, as well as in the areas around the settlements of Soledar and Avdiivka.

DM1274 (DM1274A1) Anti-personnel Mine (Germany)

An anti-tank, anti-bottom, cumulative, contact-action mine. Designed to disable enemy tracked and wheeled vehicles. Damage to enemy vehicles is inflicted by the explosion of a cumulative charge under the vehicle's bottom.

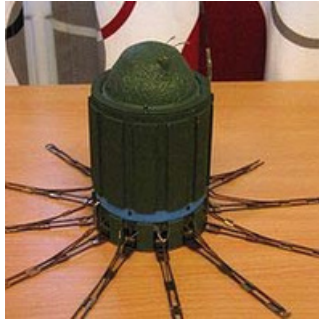

Tactical and Technical Characteristics of the DM1274 (DM1274A1) Mine

Mine type.....	underbelly, cumulative
Casing material.....	plastic, steel, polymer
Total weight.....	2.25 kg
Explosive (hexogen).....	780 g
Dimensions: diameter.....	10.5 cm
Height (to top of cap).....	16.5 cm
Target sensor height.....	45 cm
Target sensor deflection angle for mine activation.....	20°
Operating time.....	3, 6, 12, 24, 48, 96 hours
Armor penetration.....	140 cm
Primary fuse.....	DM 1234
Time to combat readiness.....	about 5 min.
(from the moment of ejection from the cassette)	
Temperature range.....	-35° to +63°
Deactivation/Retrievability	No/No
Self-disintegration/Self-neutralization.....	Yes/No

The **DM 1274** anti-tank mine (also known as the **DM1233**, **DM 1399**, and **AT2**) was developed and adopted by the Bundeswehr in 1980 for remote mining using the MARS2 multiple launch rocket system and mine-laying launchers, and was used by the armed forces of the United Kingdom, Germany, and Norway. Externally, they can be distinguished as follows: the DM1233 and DM1399 have parachutes (of different types) attached to the top of the casing, whereas the DM1274 (DM1274A1) does not.

The cumulative jet, after penetrating the vehicle's bottom (armor penetration exceeding 140 mm), damages the vehicle's internal equipment, while the high temperature of the jet and the molten armor spatter cause a fire inside the vehicle.

The mine's target sensor is a thin, upward-facing wire antenna. The mine is triggered when the vehicle's hull deflects the antenna 20° from the vertical.

In addition, the mine is equipped with a sensor sensitive to tilting or movement of the mine (an anti-extraction element) and to attempts to disarm it, which causes the mine to detonate if an attempt is made to tilt or move it. At the same time, the mine is equipped with a sensor that briefly disconnects the detonator's electrical circuit in response to ground vibrations near the mine or shock waves from nearby explosions. This enhances the mine's resistance to demining charges. The mine can be set to a service life (set via the control panel in the mine-laying vehicle's cockpit before laying begins) of 3, 6, 12, 24, 48, or 96 hours, after which it self-destructs (99% detonation rate).

Structurally, the mine consists of a ribbed green plastic casing (1). Twelve spring-loaded steel legs (2) are inserted into the longitudinal ribs of the casing and hinged at their lower ends. When these legs are extended, they ensure that the mine stands vertically on the ground. During transport and while the mine is in flight to its deployment site, these legs are held in place by a steel retaining band (3) that encircles the mine's casing. This retaining strap is closed and held in this position by a special locking pin that protrudes from inside the mine and is part of the safety mechanism. Once the mine is ejected from the cassette, hits the ground, and the process of arming the mine begins, the pin releases the retaining strap. Since the strap is spring-loaded, it will uncoil into a straight line and detach from the mine. The released prongs will snap back with force, bringing the mine body into a vertical position.

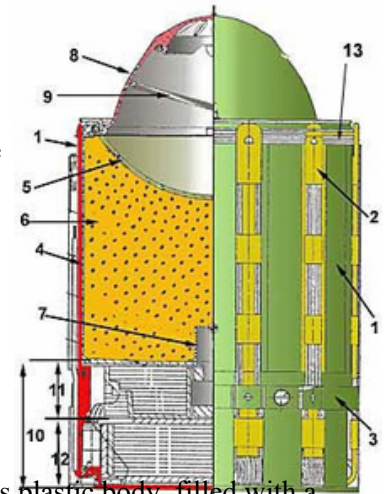

Structurally, the mine consists of two main components:

The Warhead and the Functional Section (10).

The warhead is a thin-walled steel casing (4) inserted into the mine's plastic body, filled with a mixture of hexogen (94.5%), plasticizer (4.5%), and graphite (1%) (6). The code for this explosive according to the German nomenclature is R 8151. The total mass of the explosive is 780 grams, which provides armor penetration of up to 140 mm. The top of the casing is sealed with a red copper liner (5), which forms a hemispherical cumulative cavity. At the bottom, the casing has a socket (7) for the fuse's intermediate detonator.

A cap (8) made of flexible plastic is secured to the top of the casing. Inside, it is held in place by two springs (9). When the mine is in its transport position (inside the cassette), this cap is pressed inward into the cumulative cavity, which reduces the distance between mines in the cassette. After ejection from the cassette, the cap is pushed outward by the springs. The cap serves a dual purpose. First and foremost, it prevents the mine from resting on the ground with the upper part of its body until the legs are deployed (in other words, from standing "on its back"). Thanks to the cap, the mine will always land on its side (unless it accidentally lands on its bottom).

The cap's second function is to maintain free space above the cumulative cavity throughout the mine's operational life.

The primary target sensor is the S3 sensor, located in the upper part of the mine's body; it consists of an electrical switch with an antenna that extends about 45 cm above the mine. The antenna is made of springy steel wire. In the transport position (when the mine is in the cassette and before the legs are deployed), the antenna (13) is wound around the upper part of the body and held in place by the legs (2). As soon as the legs swing out during the process of bringing the mine into the combat position, they simultaneously release the antenna, which, due to its springiness, straightens out and assumes a vertical position.

The sensor is electrically connected to the DM1234 fuse (11), located in the functional part of the mine (10).

When a target (a tank or other vehicle) deflects the antenna by more than 20 degrees, the sensor transmits a signal to the fuse via wires running inside the casing. The fuse's electronic section processes the signal and, depending on the signal's characteristics, either issues a detonation command or rejects the signal. A deflection of the antenna lasting a certain duration is required to trigger the explosion. The fuse does not respond to brief deflections or oscillations caused by gusts of wind, impacts from flying objects (clumps of earth, shrapnel, bullets, etc.), and the like.

The functional part of the mine is located at the bottom of the casing and is, in turn, divided into two main assemblies.

The lowest assembly is the battery pack. It contains two lithium batteries that power the electronic and electrical circuits of the fuse, which is located above the battery pack. While the mine is stored in the cassette, the batteries are disconnected from the power supply. At the start of the mine's ejection from the sub-cassette tube, special devices (activators) located at the top of the battery pack connect them to the fuse's power supply. From that moment on, the batteries serve as the power source. The batteries cannot be removed from the pack.

In addition to the batteries and activators, **the battery pack** contains an S7 sensor, which detects ground vibrations and shock waves from the explosions of other munitions and temporarily shuts down the fuse's electronics, thereby preventing an unauthorized detonation of the mine. This ensures the mine's resistance to nearby detonations of any munitions, including demining charges.

The battery pack also contains a connector to which the programming cable is connected. The minefield controller's remote control is used to set the mine's operational time via this cable. Wires from the connector run through the battery pack to the electronic section of the fuse.

Above the battery assembly is the DM1234 fuse, which is structurally divided into a mechanical component and an electronic circuit. The mechanical component of the fuse prevents unauthorized detonation in the event of electronic malfunctions before the mine is in its combat position. This is achieved by a safety bracket that protrudes from the mine's casing and rests against the wall of the sub-cassette tube; this bracket keeps the initiation circuit (electric detonator, detonation booster, main charge) in an open state until the mine is ejected from the sub-cassette tube, touches the ground, and the program for bringing the mine into a combat-ready position is completed.

The fuse's electronic circuit activates after the mechanical component completes the disarming process.

The electronic circuit primarily monitors the battery voltage and, if the voltage drops below a certain level, prematurely issues a command for the mine to self-destruct. This prevents mine failure due to power supply malfunctions (such as old, leaking, or frozen batteries). However, if by the time the mine is armed the batteries are unable for any reason (expired, frozen, etc.) to supply the voltage required for the electronic circuit to function, the mine will fail completely. However, it is impossible to determine this externally, and the only option is to wait for the doubled maximum operational lifetime (192 hours) to elapse.

If the position of a mine in the armed state changes (due to movement or tilt), this is detected by sensor S7, and the electronics issue a command to detonate the mine. This prevents anyone from manually clearing a path through the minefield.

Thus, a mine may detonate in the following cases:

1. When a target strikes the antenna (sensor S3).
2. When the mine's position changes or it fails to assume a vertical position after falling (sensor S1).
3. Expiration of the operational life (timer).
4. When the voltage of the power sources drops below the threshold value (monitoring device).

The mine will not detonate in the following cases:

1. Brief exposure of the antenna to random factors (sensor S3).
2. Malfunction of the power sources or electronic circuitry occurring before the mine is armed.
3. Failure of the fuse's mechanical components during the process of arming the mine.
4. When the mine is subjected to ground vibrations and air shock waves from nearby explosions of other munitions (sensor S7).

The process of arming the mine:

1. The mine is located in the cassette's feed tube. A signal is transmitted from the Scorpion mine layer's control panel via a cable network to the mine, setting the mine's operational time.

2. When the "Fire" button on the Scorpion mine layer's control panel is pressed, the mine's capacitors are charged from the vehicle's onboard power supply, and simultaneously, the mine's batteries are connected to the electronic component of the fuse.

3. A fraction of a second later, a pyrotechnic charge ejects the cover of the sub-cassette tube, and immediately afterward, an expelling charge ejects the five mines contained within that sub-cassette tube.

4. Once the mine has left the tube, its safety clip—which had previously been pressed against the tube wall—pops out, allowing the program to continue and bring the mine into combat-ready position. From this moment on, the mine's combat timer begins counting down.

5. During flight, a spring lifts the mine's cap outward; as a result, the mine,

landing on the ground, will rest either on its side or on its bottom. The cap prevents it from landing upside down.

5.5 minutes after the mine is ejected from the tube, the program for bringing the mine into combat readiness will complete its operation. However, the final steps of the program, which take 10–11 seconds, will be executed only if the mine has already struck the ground by that point.

6. As the arming sequence proceeds, the pyrotechnic charge releases the spring-loaded strap that was holding the spring-loaded legs in place and simultaneously rotates the detonator holder—with the detonator—into the combat position.

7. The released legs, due to their springiness, snap sharply to the sides and raise the mine into the combat position (if it had been lying on its side up to that point). Thereafter, these legs will ensure that the mine remains in a stable vertical position.

From this point on, the mine is in an active state and will detonate if it is tilted or if its antenna is struck by a vehicle's body.

Failed **mines are destroyed** using two explosive charges, each weighing 500 grams, applied to the mine's casing. In doing so, it is necessary to wait at least 96 hours from the moment such a mine is detected. The destruction of failed mines by firing at them with small arms or automatic cannons, as well as using mine trawls, is prohibited due to the ineffectiveness of such methods.

These mines can only be deployed in combat using the Scorpion mine launcher. To do so, five cassettes are loaded into one of the Scorpion mine launcher's launch containers. The launcher has a total of six launch containers. The launcher thus carries 600 DM1274 (DM1274A1) mines.

The mines are stacked one behind the other in the sub-cassette tube and are separated by disc springs and conical springs, which are in a compressed state. Behind the first mine is a 35-gram ejection charge, which propels all five mines out of the launch tube at once (though not simultaneously from all the cassette's launch tubes, but sequentially at specific time intervals set on the mine layer's control panel).

Thanks to this ejection system, all five mines land on the ground in a single line at the following distances from the mine layer: Mine 1—10–18 meters,

Mine 2 – 17–23 meters,

Mine 3 – 23–29 meters,

Mine 4 – 29–35 meters,

Mine 5—34–42 meters.

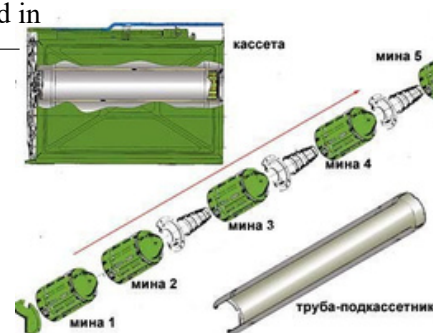

Of course, the mine launcher's launch containers are positioned at an angle to the vehicle's axis of movement, which ensures a distinctive mine layout on the terrain. Figuratively speaking, if the vehicle's axis of movement is considered the trunk of a Christmas tree, then the groups of mines form the branches of that tree.

In September 2022, Germany transferred two MARS 2 multiple rocket launchers and 200 rounds of ammunition to Ukraine. At the same time, minefields containing these mines were discovered in the Kherson region. In addition, these mines were also found near Donetsk.



DM 1399 (AT-2) anti-tank mine (Germany)

This is the same DM1274 mine, modified for other remote-mining systems, and is designated as:

***DM1233.** Used in LARAT 2 rockets of the LARS (Waffensystem LARS) multiple launch rocket system for the remote laying of minefields. Each rocket carries 5 mines.

***DM1399.** Used in the rockets of the MARS (Waffensystem MARS) large-caliber multiple launch rocket system for the remote laying of minefields. Each rocket carries 28 mines.



All variants of the DM1274 mine are designated identically—**AT-2**—in Russian sources and in the vast majority of foreign sources, although this designation is not used in German documents on mine

weapons, this designation is not used. They can also be distinguished by their appearance. The DM1233 and DM1399 have parachutes (of different types) attached to the top of the casing, whereas the DM1274 (DM1274A1) does not have any.

Originally, the AT-2 was a projectile for multiple-launch rocket systems and rocket artillery. The projectile contained mines: DM1233, DM1274, or DM1399. It was this latest version that was supplied to the Ukrainian Armed Forces in 2022–23.



A single 227-mm AT2 rocket carries 28 DM1399 mines. This means that a pack of 6 rockets can deploy 168 mines at once, and a double pack, consisting of 12 rockets: 336 mines.

A fragment of an AT2 rocket from the "HIMARS" MLRS shot down by our air defense.



Technical Specifications of the DM1399 Mine

- Weight: mines.....2.22 kg.
- Explosive.....0.9 kg
- Diameter: 103.5 mm.
- Height.....160 mm.
- Height with target sensor (antenna) extended.....700 mm.
- Housing material.....Composite, plastic, metal .
- Armor penetration capability.....up to 140 mm.

After the missile is fired (with a possible range of up to 38 km), the mine cassettes deploy. To avoid hard contact with the ground and detonation, the mines are equipped with plastic parachutes. They land gently on them. The parachute detaches. Spring-loaded legs deploy, the mine bounces, and if everything is functioning normally, it stands upright. A target sensor is released, along with a trigger mechanism resembling an antenna. It stands upright, rising 70 cm above the ground.

The mine is in combat position.





A mine stuck in the mud, with a parachute next to



DM1399 mine with a partially exterior

plastic casing.



The DM1399 mine has deployed correctly. The parachute and sensor antenna are visible. The target is sticking out.

Themineis designatedas:

- * **DM1233.** It is used in LARAT 2 rockets of the LARS (Waffensystem LARS) multiple launch rocket system for the remote deployment of minefields. Each rocket carries 5 mines.
- * **DM1399.** Used in rockets of the MARS (Waffensystem MARS) large-caliber multiple launch rocket system for the remote deployment of minefields. Each rocket carries 28 mines.

According to some sources, in addition to a contact target sensor, a magnetic fuse is also provided. Therefore, the mine can be triggered by a vehicle passing nearby—not directly “over” it, but to the side. It is triggered by the approach of a large metal object: a sapper wearing a body armor vest with steel plates,

a probe, or a mine detector. It is difficult to verify the accuracy of this claim. The mine definitely does not like being touched or having its mechanism tampered with after it has been deployed in a combat position. It clearly has an anti-removal system. It may explode if attempts are made to lift it or tilt it from a vertical position, even without the presence of metal objects and without contact with the target sensor. This is where its particular insidiousness and danger lie—for sappers, ordinary infantrymen, and civilians alike.

The mine is equipped with a self-destruction system with several time settings, ranging from 6 to 90 hours (4 days). There have been known cases where the much-touted German self-destruction system—claimed to have a 99% success rate—failed to activate. Thus, there is a risk of encountering such mines in an unknown state of operational readiness, even months or years after the area was mined.

Since the DM1399 mine is primarily designed to target armored vehicles, it does not contain any pre-formed projectiles specifically intended for highly effective engagement of infantry. However, within a 30-meter radius, fragments from the mine’s body (legs, sensor) can inflict significant damage.

Disarming the DM1399 should be entrusted to experienced bomb disposal experts. The mine () can be triggered simply by approaching it, especially if metal objects are present. Therefore, bomb disposal experts should wear special suits providing maximum protection against shrapnel, along with a helmet with a visor. The TNT block is carefully brought close to the mine using a pole or a long branch. It is important not to touch or disturb the mine, but also to place the charge right up against it.

Approaching is also dangerous because the self-destruct mechanism can go off at any moment , and it’s better to stay at least 2–3 meters away (at the distance of a stick or rod) than to get too close. In theory, it’s possible to shoot at such mines with small arms—it’s been done before. But the risks are clear. However, there have also been cases where bullets destroyed the mine without causing it to detonate. You must wear a body armor vest with maximum fragmentation protection, ballistic goggles, and a helmet, and stay no closer than 30 meters. It is advisable to shoot from behind cover, such as a rock, a tree, or a parapet.

We also encountered mines that looked similar but had different markings (DM1443), which suggests that development is ongoing.

The mine was used by the Ukrainian Armed Forces along the entire front line.

HPD F2 Anti-Tank Mine (France-Switzerland)

An anti-tank, anti-bottom mine with a cumulative effect. HPD indicates that



the mine has high destructive power. It is designed to destroy armored vehicles using a cumulative jet (projectile) when the vehicle passes over the mine.

The HPD-2 is an evolution of the HPD-1 mine. It incorporates a number of improvements to both the warhead and the fuze. It is said that the mine's warhead is a "second-generation" Mishnay-Chardin-effect design capable of penetrating up to 150 millimeters of armor. In addition, it can be laid at depths of up to 1.5 meters underwater.

Tactical and Technical Characteristics of the HPD F2

Mine Type.....	anti-tank, anti-hull, cumulative
Casing material.....	plastic
Weight: total.....	7.0 kg
Explosive (hexolite).....	3.0 kg
of explosive charge.....	140 g
Dimensions: Length.....	27.83 cm
Width.....	18.9 cm
Height.....	10.4 cm
Depth of the hole for mine placement.....	30 cm
Thickness of the covering layer: soil.....	up to 15 cm
snow.....	up to 50 cm
water.....	up to 1.5 m
Min. distance between adjacent mines.....	2.5 m
Target sensor sensitivity.....	Metal weighing over 1 metric ton at a distance of less than 1 m
Armor penetration.....	up to 100 mm of armor
Time to reach combat readiness.....	10 min. from the moment the button is pressed the timer is activated
Power source.....	2 lithium batteries, 3.6 V, 1.9 Ah connected in series Setup time .
.....
.....
.....
.....
Operational life.....	30 days
Operating temperature range	-35 to +65°C
Main fuse.....	built-in magneto-electronic
Disarmability/Retrievability.....	No/No
Self-destruction/self-neutralization.....	No/Yes

HPD F2 mines are non-defusable and non-retrievable.

Switzerland became the first foreign customer, acquiring a license to manufacture the weapon. Locally produced mines were designated Panzerabwehrmine 88 (Pzaw Mi 88). Orders then came from Belgium and Norway; they received finished products from France.

Production of the HPD F2 mines was established in two countries (France and Switzerland). The HPD F2 mine features a plastic casing and has a distinctive appearance due to the characteristics of its layout. Structurally, the device consists of two parts.

The first is a flat "platform" with a side instrument compartment containing all the control equipment, including an electronic fuze with a magnetic target sensor, a safety device, a self-neutralization system, a power supply system (two lithium batteries), a pyrotechnic fuse and an arming mechanism. A rotatable arming handle (1) is located at the end of the casing, and on the side is a button (2) to activate the electronic timer, which initiates the arming process.



The **second** component is the cylindrical warhead, mounted on the flat base of the first. It contains a blast charge to clear away any soil or snow covering the mine, as well as the main cumulative charge.

The target sensor is triggered when large metal objects approach. Based on the characteristics of the magnetic field, it can determine exactly how an armored vehicle is approaching the mine and select the optimal detonation mode. In addition, the target sensor may be triggered by small metal objects, such as sapper tools. The device responds with immediate detonation to the radiation from a mine detector, an attempt to remove it, etc.

The electronic fuse determines which part of the target is above the mine and, depending on this, adjusts the mine's detonation mode:

*If the target's underside is above the mine, a black powder ejection charge is first triggered, which removes the camouflaging layer of soil; 100 milliseconds later, the main cumulative charge is triggered, piercing the underside of the armored vehicle.

*If the target is positioned above the mine with a track or wheel, only the main charge detonates, damaging the track or wheel through its high-explosive effect.

The warhead contains 3 kg of explosive in the form of a metal-lined shaped-charge. A so-called ejection charge is positioned above the main charge. The main warhead penetrates up to 100 mm of homogeneous armor.

The HPD F2 mine can be deployed manually or using the EMP F2 mine layer. The mine requires a hole at least 300 mm deep. It is covered with soil or snow for camouflage. The mine can also be deployed underwater at shallow depths.

General Design:

The electronic fuze components (B) are housed in the casing (A), which is covered on top by a lid (C) containing a magnetic target sensor. A cylinder (D) is inserted into the end of the housing; inside it are two power batteries and the electrical circuit closure components. A rotary handle for arming the mine is also mounted in this cylinder

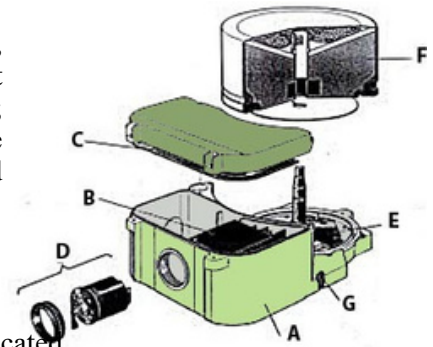

. The opposite end of the housing consists of a platform (E) on which the components of the safety and ignition mechanisms are located. The warhead (F) is mounted on the platform. In addition, a button (G) for starting the timers is located here.

Compartment containing two lithium-ion batteries.

The warhead consists of a cylindrical casing closed at the top by a cover. Inside, in the center, there is a vertical channel housing the electric igniter for the powder charge and the electric detonator for the main hexolite charge.



The main charge itself (shown in yellow in the photo) is located inside the casing and is confined at the top by a concave copper plate (shown in red in the photo), which forms a cumulative recess and creates a projectile upon detonation. Between the copper plate and the warhead casing cover is a black powder trigger charge enclosed in a pouch (shown in gray in the photo).



The charge's casing/lens, from which the impact core is formed, contains an ejection charge that, fractions of a second before the main detonator fires, blows off the cover (and the camouflage layer above it) to ensure proper formation of the impact core.



Principles of Operation and Effectiveness

The operating principles of the HPD F2 mine are quite simple. After being placed in a hole and activated, the target sensor begins monitoring changes in the surrounding electromagnetic field. When a metallic object appears, the mine detonates. If the target sensor detects that the bottom of an armored vehicle is above the mine, the warhead functions as a cumulative warhead. If a track runs over it, a high-explosive detonation is triggered.

Interestingly, the detonation occurs in two stages. First, a primer charge is ignited—its purpose is to displace the camouflaging soil and clear it from the path of the cumulative jet. Only then does the main charge detonate. The absence of obstructions allows it to achieve maximum performance.

The HPD F2 is capable of penetrating up to 100 mm of homogeneous armor. This is sufficient to penetrate the hull bottom of virtually any modern tank. It also penetrates any other armored vehicles lacking specialized anti-mine protection. Consequently, despite its considerable age, the French mine remains a highly effective weapon.

The mine reacts to the magnetic field of a target and cannot distinguish between different types of vehicles. As a result, it poses a danger not only to combat vehicles but also to civilian transport and specialized equipment. Furthermore, the target sensor is triggered not only by military vehicles but also by the scanning signals of metal detectors. Therefore, the HPD F2 is also dangerous to sappers conducting mine clearance operations. This is an indiscriminate weapon that functions as a trap for sappers.

Reality: *The mine works quite effectively when detonated under a tank's hull, but if a tank runs over it with its tracks, the mine functions as a high-explosive device, since the conditions for a cumulative jet to form. Its charge is insufficient for such cases. It cannot sever the track of a modern tank. It can damage it, yes. It is possible that after some time this will lead to the track breaking off. But when?*

Mine Deployment



All operations for laying the mine and arming it during mechanized deployment are performed by the mine-laying vehicle's mechanisms. During manual deployment, place the mine on the ground or in a hole, press button (2), then turn handle

(1) clockwise until it stops, so that the plate in the center is tilted to the right. After 10 minutes, the mine will be armed. During these 10 minutes, the mine is safe and can be covered with a layer of soil for camouflage. Also, during this time, the process of arming the mine can be paused by pressing the button and turning the handle counterclockwise until it stops.

While active, the mine cannot be defused or removed.

Moving metal objects (such as a shovel, weapon, etc.) near the mine may cause it to explode.

Searching for the mine using an electromagnetic metal detector (metal detector) will definitely cause the mine to explode.

Moving the mine or tilting it will cause it to explode.

A drop in voltage (reduced performance) of the power sources will cause the mine to explode.

The mine self-neutralizes after 30 days via a built-in timer.

The mine's design allows it to be removed after self-neutralization and sent to the factory for rearmament. To ensure safety during this process, press the side button and turn the arming knob to the left until it stops.

The HPD-3 is a further development of the HPD-2 featuring a programmable fuse. It has a three-pin interface for a programming device. It can be set for an active period of 30 days, after which it self-neutralizes, or for a shorter active period ranging from 4 to 96 hours, after which it self-destructs.

These mines began appearing in August 2022 in the area around the village of Opytnoye near Donetsk, as well as in the Artemovsk area.

UMK Anti-Vehicle Anti-Hull Mine (Poland)



The UMK anti-vehicle, anti-bottom mine strikes the target with an impact projectile

Key Specifications:

- Dimensions: diameter.....262 mm
- height without pin.....226 mm
- Height with pin.....1010 mm
- Explosive (TNT).....5.5 kg
- Target sensor.....pin-type, pressure-activated, electrically controlled detonator
- Activation force: pressure-activated..... 200–500 kg inclined15°
- Penetration.....50 mm of steel or 70 mm of reinforced concrete (from a distance of 50 cm)

UMK mine configuration:

In a standard container with 2 mines:

- 1– pressure-sensitive target sensor;
- 2– MD-2 detonator;
- 3– Electric detonator;
- 4– Adapter between the sensor and the MD-2



Two configurations are available:

- with a push-button target sensor;
- with a pin-type target sensor;

Installing a mine with a pin-type target sensor



Pin-type target sensor sleeve



Set to live by pulling the cover



Screw in the MD-2 fuse



Screw in the loaded sleeve into the hole



Camouflage the mine with a small layer of soil (do not should not interfere with the formation of impact core)



Unscrew cover



Avoiding tilt, install pin sensor

Used by Ukrainian Armed Forces units during the special military operation in Ukraine

**MN-123 anti-tank mine
(Poland)**

The mine consists of a flat cylinder with a beveled edge. It is typically laid using remote-laying systems.



It can also be laid manually. Like the MN-121 mine, it uses a magnetic fuse that detects when a vehicle passes overhead. It is also equipped with an anti-tamper device. Cumulative cavities are located on both faces, allowing the landmine to function effectively in any orientation. The fuse ensures that the mine detonates beneath the entire projection of the target vehicle.

The fuse has three independent protective elements and can be programmed for self-destruction (SD) after 2, 3, or 5 days (according to other sources, up to 30 days). It is powered by a 6.8-volt battery. The mine was manufactured in 2004.

Main Technical Specifications

- Dimensions: diameter.....18 cm
- height.....9 cm
- Weight: total.....3.7 kg
- Explosive
- Fuse type.....magnetic
- Self-destruction.....Yes
- Self-neutralization.....Yes
- Armor penetration 60 mm at 0.5 m



for SDM installation



for manual deployment

The mine is highly resistant to electromagnetic fields (proximity to high-voltage power lines, radio transmitters, and lightning strikes), electronic countermeasures (ECM), and explosions from other munitions. It also features an anti-stuck-in mechanism (AHD).



The mine is available in three versions: the MN-123 combat mine, the MN-123S training mine, and the MN-123/O mock-up. The mines are packaged in mine cassettes of 5 pieces each. The mine cassette allows mines to be launched from a TME or MZK-E multifunctional unit mounted on a barrier. Thanks to the mines being packed in cassettes, the unit can be loaded

quickly and efficiently, and the time required to load 400 mines into 4 cassette units does not exceed 80 minutes.

The SMHSW-K “Croton-K” (“Baobab”) mine barrier is equipped with 4 launch modules. A single launch module can carry up to 20 containers (4x5).



Taking into account Russia’s combat experience with the “Zemledelie” mine-laying system, Poland developed its own “Baobab-K” system, which holds 600 mines (its primary armament consists of



MN-123 anti-tank mines). The vehicle is equipped with six launchers for deploying mines. The time required to lay a minefield using all mines loaded on board is approximately 22 minutes.

An onboard computer regulates the rate at which mines are fired while the vehicle is in motion. The parameters and coordinates of the minefields are recorded on digital maps and displayed on the computer screen. All data can then be transmitted via communication channels to higher command.

The Baobak-K deploys mines at a distance of 30 to 90 meters using propellant charges. Meanwhile, the Russian

“Zemledelie” system, by firing rocket-propelled projectiles, operates at a range of 5 to 15 km, which allows it to avoid being present on the front lines, unlike its Polish “counterpart.”

In 2025, the PMN “Bluszcz” (Ivy) mobile unmanned remote-mining system was unveiled. It is equipped with 20 cassettes, each containing 5 MN-123 anti-tank mines. The control system allows the system to be operated in both manual and automatic modes and is designed for rapid remote mining.

The system can lay a minefield 30–90 meters wide.

Mine density: variable, programmable by the operator.

The system includes the following additional equipment:

- *Daylight and IR cameras
- *Situational awareness system
- *Data exchange and recording of minefield coordinates
- *Fully remote control / autonomous navigation (manual control is also possible)



In addition, an unmanned aerial vehicle (UAV) has already been developed for dropping mine data.

Given recent developments in the hostilities in Ukraine, I expect that both UAVs and mines will soon be deployed by the Ukrainian Armed Forces for testing under combat conditions—primarily ground-based and airborne robotic SDMs.

MR-123 anti-tank mine (Poland)

The MR-123 anti-tank mine is designed to engage tracked and wheeled military vehicles. The fuze ensures detonation beneath the entire projection of the target. The mine is deployed **manually**. It is equipped with a non-contact electronic magnetic fuze. The mine's orientation on the ground during deployment is irrelevant, as it is equipped with two oppositely positioned cumulative charges. This design allows the mine to be deployed by throwing it from behind cover to the desired location. The mine features programmable mechanisms for non-retrievability, self-destruction, or self-neutralization after a set period of time (from 1 to 30 days).



Initially, it was planned to equip the mine with an electronically programmable fuze (similar to the one used in the MN-123), but ultimately the mine was fitted with a fuze programmable via mechanical switches located on the side of the mine.

Main Specifications:

Dimensions: diameter.....167 mm
 height.....90 mm
 Weight: total.....3.7 kg
 Explosive
 Armor penetration.....60 mm from 0.5 m

The mine is highly resistant to electromagnetic fields (proximity to high-voltage power lines, radio transmitters, and lightning strikes). It is also resistant to nearby detonations of other munitions and demining charges.

**MC-71 Anti-Tank Mine
(Romania)**

The MC-71 is a Romanian anti-tank, anti-bottom, cumulative mine with a pin-type target sensor mounted on an external support. The mine's body consists of two truncated cones, the lower of which contains the main charge and the detonation mechanism. The main charge is a large cumulative charge that detonates 0.2–0.4 seconds after the pin is struck. The mine is manually placed in the ground so that when a target strikes the detonator pin, the mine is positioned beneath the center of the vehicle's underbelly. To achieve a simultaneous detonation of multiple mines, a single detonator can be installed to initiate them all at once. The inclined sensor can be oriented toward the mine, which potentially makes it effective against mine-clearing vehicles that use mine trawls.



Key Technical Specifications:

Housing material.....metal
 Weight: total.....8.2 kg
 VV (T-40).....5.1 kg
 Additional detonator.....225 g of compressed TNT
 Dimensions: diameter.....260 mm
 Height.....350 mm
 Actuation force..... 10–20 kgf
 Height of the pin-type DC.....65 cm
 Actuation angle of the DC.....30°



The MC-71 is similar to the French Modèle 1951 mine and the Czechoslovak PT Mi-P.



Method of connecting the mine to the remote fuse

Used by units of the Armed Forces of Ukraine during the special military operation in Ukraine

BLU-91/B anti-tank mine (U.S.)

Anti-tank anti-bottom mine. Designed to disable enemy tracked and



wheeled enemy vehicles. The inflicts damage on enemy vehicles by piercing the vehicle's bottom with a cumulative jet.

Damage is inflicted by splashes of molten armor from the vehicle's bottom and by fragments from the tank's exploding ammunition. According to the classification of destructive properties, the mine belongs to the K-Kill type. (destruction of the tank and crew). It was adopted by the U.S. Army, Naval Aviation, and the Marine Corps in 1979.

It is deployed only by being dropped onto the surface.

It is part of the VOLCANO remote mining system.

The M87 cassette holds 5 BLU-91/B mines and 1 BLU-92/B anti-personnel mine. The mine delivery system consists of a mine dispenser (4 containers and a control unit) mounted on a cargo truck, an M548 tracked transporter, or a UH-60 "Black Hawk" helicopter. It is also a component of the "Gator" aerial mining system

The mine carriers are:

*The 1,000-pound CBU-89/B aerial drop bomb cluster, which holds 72 BLU-91/B mines plus 22 BLU-92/B anti-personnel mines.

*The 500-pound CBU-78/B aerial bomb cluster, which holds 45 BLU-91/B mines and 15 BLU-92/B anti-personnel mines.



Mine Specifications

Mine type.....	Anti-tank, anti-vehicle.
Casing	Steel.
Weight.....	1.7 kg.
Explosive weight (RDX).....	0.585 kg
Diameter.....	12 cm
Height.....	6 cm
Target sensor.....	Magnetic
Dimensions of the lightweight housing	14.5 × 14.5 × 8 cm.
Operational time.....	4 hours, 48 hours, 15 days.
Time to deploy.....	2 min.
Operating temperature range	-10 to +50 degrees.

The BLU-91/B mine is similar in itself to the M70, M73, and M78 mines, but differs from them in that it is housed in a lightweight plastic casing with specific aerodynamic properties. This ensures an even distribution of the mines over the target area after the aerial bomb is released in flight.

The mine detonates when the vehicle's magnetic field acts on the fuze. The delay time is calculated so that the explosion occurs beneath the center of the vehicle's hull. All mines are equipped with an anti-removal mechanism that triggers the mine's detonation if an attempt is made to alter its position (shift, move, turn, or lift it). The fuze is a non-contact electromagnetic fuze that is an integral part of the mine's design.

The mine cannot be defused.

The mine's operational lifespan is fixed at 4 hours, 48 hours, or 15 days, after which the mine self-destructs. The operational lifespan is set by the operator before mining begins, once the mines have been loaded into the carrier. ***The self-destruction of the mines begins:*** for mines with a 4-hour operational lifespan, after 3 hours and 12 minutes; for mines with a 48-hour operational lifespan, after 38 hours; and for mines with a 15-day operational lifespan, after 12 days and 14 hours.

The Ukrainian Armed Forces were recorded using this mine during the special military operations early as 2022.

's M70 and M73 anti-tank submunitions (U.S.)

Essentially, these are two anti-tank mines that are part of the RAAM remote-deployment system within the FASCAM family of scatterable mines; however, since their method of delivery to the



deployment site differs from that of traditional mines, the U.S. Army's nomenclature, they are classified not as mines but as ammunition—more specifically, as warheads. Both mines are completely identical in appearance, dimensions, design, and explosive-weight characteristics, differing only in their operational life (*self-destruction time*).

The M70 mine has an operational life of 4 hours.

Nine of these mines fit into a 155 mm M741 howitzer shell.

The M73 mine has an operational duration of 48 hours.

Nine of these mines fit into a 155 mm M718 howitzer shell.

There are also upgraded versions, the M741A1 and M718A1, with a slight change in the mine arming time, from 2 minutes to 45 seconds.

Anti-tank, anti-hull, cumulative mine.

Designed to neutralize the crews of tanks and other vehicles. The fuze reacts to the vehicle's magnetic field and initiates detonation upon reaching a predetermined threshold magnetic field strength. Mines that land flat, regardless of which side is down, are triggered by the magnetic sensor when armored vehicles pass over them, or nearby, from the side.



Damage is inflicted by molten armor spatter resulting from the cumulative jet piercing the hull bottom and by fragments from exploding shells in the tank's ammunition load. Based on its destructive properties, the mine is classified as a K-Kill (destruction of the tank and crew).



Tactical and Technical Characteristics of the M70 Mines

	M70	M73
Mine type	anti-tank anti-bottom cumulative	
Casing	metal.	
Weight.....	1.7 kg.	
Explosive weight: hexogen (RDX)	585 g	
Diameter	12 cm	
Height	6 cm	
Target sensor	magnetic	
Trigger range	1 m perpendicular to the mine's plane (on both sides)	
Operational life	4 hours	48 hours
Time to bring into combat position		45–60 sec.
Projectile type	M741	M718
Operating temperature range		-20 to +50 degrees

There are no markings on the casing. Therefore, it is impossible to identify the specific model based on external features. It may be mistaken for some household item or part—be careful!

Just a box, a "washer," a thick disc, without any external markings



Both mines were adopted in 1975. The mine is deployed only by being dropped onto the surface at . It is delivered to the deployment site inside a 155-mm artillery shell

Construction of the M70 and M73 mines

- 1– Mine casing
- 2– Main charge
- 3– Control board
- 4– Fuse and delay unit
- 5– Cumulative warhead casing
- 6– Intermediate charge
- 7– Cover
- 8– Impact lens
- 9– Retaining ring
- 10– Ejection charge

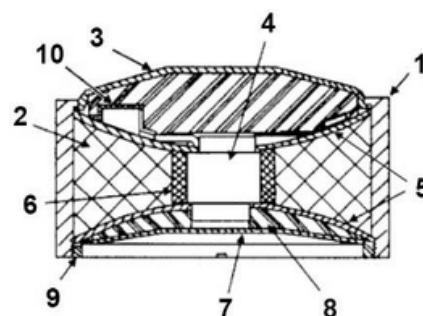

General internal structure of the M70 mine

The mine dispersion across the terrain from a single projectile is up to 600 meters from the aiming point . Depending on the required density of the minefield at that location 6 to 96 shells are fired. A so-called minefield module is thus formed around the aiming point. Depending on the steepness of the shell's flight trajectory, the resulting minefield density, and the rate of shell consumption, the size of the minefield module is defined. The minefield is defined as 200 × 200 meters or 400 × 400 meters. This module guarantees a density of ad , although in reality the dispersion ellipse is approximately 500 × 1,500 meters. The minefield consists of the required number of modules. The range of the minefield from artillery positions depends on the range of the howitzers and is up to 18–24 kilometers.

At the manufacturing plant, the mines are packed into projectile casings in sets of 9. The fuses are automatically armed 45 seconds to 2 minutes after being ejected from the projectile. 20% of the mines (1–2 mines per projectile) are equipped with an anti-removal mechanism and detonate if an attempt is made to move them from their position. All mines detonate when exposed to the electromagnetic field of a mine detector. ***None of the mines can be defused.***

A significant drawback of the mine is that it must not fall onto hard surfaces (asphalt, concrete), as this may result in damage to the mine's casing or failure of its mechanisms. Self-destruction of the M70 mines begins after 3 hours 12 minutes, and the M73 after 36 hours from the moment they are activated.

The mines do not withstand freezing temperatures well. Thus, the M73, even

at -8 degrees (and even more so at lower temperatures) may have its until self-destruction by a factor of 2–4, down to 12–24 hours.

Up to 15% of the mines may be scattered beyond the boundaries of the minefield. *Debris from the spilled explosive can be seen*



An M70 (M73) mine destroyed by impact.

minefield. Since there are two cumulative craters (pointing in opposite directions), it makes no difference which side of the mine is facing up. However, if the mine is tilted, the path of the cumulative jet increases, and the effective armor thickness increases. This reduces the mine's effectiveness. If the mine landed on its side or became stuck in thick mud or deep snow, it will not detonate as intended.

Another M70 (M73) mine, destroyed upon impact



It is essential that exactly one of the flat surfaces be facing upward and positioned close to



the horizontal. These mines are ineffective against tracks, as they merely punch a hole in the track.

The mines have no markings, distinctive features, holes, covers, screw heads, etc. **They are painted green or gray-green.**

A study of these mines' behavior in Arctic conditions (northern Canada) showed that in deep snow (more than 20 cm), 40 to 60% of the mines do not lie with their flat side facing upward and are therefore unable to fulfill their intended purpose.

Temperatures below -8 degrees cause the voltage of the power sources to drop prematurely, leading to the mines' self-destruction 12–26 hours after deployment. While this is insignificant for M70 mines, M73 mines will fail to fully fulfill their intended purpose.

These mines cannot penetrate the underside of the Soviet BMR-3 mine-clearing combat vehicle.

A tank or BMP track will remain undamaged by a nearby explosion. After all, the mines are small, and their explosive charge is modest. If a track runs directly over one, it might be torn off—or it might not. It will punch a hole in the track, but it will only tear it off if it strikes the point where the track links to the adjacent link.

The greatest danger, however, comes from M70 (M73) mines when they detonate in an anti-vehicle configuration.

Sometimes, when they fall onto trees, asphalt, or other obstacles, the mines are destroyed and do not detonate.



Defusing M70 and M73 Mines

M70 and M73 mines cannot be removed from their combat positions. Therefore, defusing boils down strictly to destroying them on the spot. The classic method is detonation on site.

However, one should not approach them, as the self-destruct mechanism or anti-extraction mechanism might suddenly activate.



Therefore, a TNT block with a fuse is brought close to the munition using a fairly long branch or pole. It is ignited, and the operator runs away along a safe route to take cover. Since the explosion is more powerful due to the addition of the TNT block's explosive charge. You can attempt to shoot at it with small arms while wearing personal body armor and staying no closer than 40–50 m. The explosive is more reactive than TNT and therefore detonates upon being struck by bullets.

There are reports that up to 20% of mines are equipped with traps designed to target sappers and curious onlookers, which are triggered when anyone attempts to move them. We have not been able to verify this information 100%, but this possibility must be kept in mind. It's possible that the self-destruction simply occurred at the same time. This must be taken into account during disposal.

Such mines are shot at with assault rifles on the road, ahead of the team. You can get a rough idea of the explosion's scale.

These mines were discovered in the area of Svatovo, Lysychansk, and the Krasnorechensky District.

M78 anti-tank submunition (U.S.)

Anti-tank, anti-bottom, cumulative mine. Designed to disable tanks and other armored vehicles. According to its classification by destructive properties, the mine belongs to



of the K-Kill type (destruction of the tank and its crew). The fuse reacts to the vehicle's magnetic field and initiates an explosion upon reaching a preset threshold value of magnetic field strength. On light vehicles (motorcycles, passenger cars, trucks), the fuse may not react at all. Damage is inflicted by molten armor spatter resulting from the penetration of the hull bottom by the cumulative jet and by fragments of exploding shells from the tank's ammunition load (according to the U.S. Army Field Manual FM 20-32).

Technical Specifications of the mine

Mine Type.....	anti-tank, anti-bottom, shaped-charge
Casing	Metal.
Weight.....	1.7 kg
Explosive weight (RDX).....	585 g.
Diameter.....	12 cm
Height.....	6 cm
Target sensor.....	Magnetic
Sensitivity.....	100 cm perpendicular to the mine's plane
	(on both sides)
Operating time.....	adjustable: 4, 8, 12, 16 hours
Time to arm	2 min. Operating temperature range -
	20 to +50 degrees

In terms of appearance, dimensions, explosive-weight characteristics and destructive capability, and fuze, it is indistinguishable from the M70, M73, and M75 mines, except that a sort of steel cage with spring-loaded legs is fitted over the cylindrical body. Their purpose is to ensure the mine is positioned correctly on the ground—that is, not on its side, but on its top or bottom surface.

The mine was adopted on March 6, 1992. It is deployed only by scattering. Essentially, it is an antitank mine that serves as the main component of the MOPMS remote mining system from the FASCAM family of scatterable mines; however, since its method of delivery to the deployment site differs from that of traditional mines, the U.S. Army classification system designates it not as a mine but as a sub-munition.

MOPMS is the acronym for the M131 Modular Pack Mine System (MOPMS), which stands for Modular Containerized Mine System. It consists of a portable container weighing 54.43 kg, which holds 7 tubular cassettes (launchers) containing mines. Each cassette holds 21 mines (17 M78 anti-tank mines and 4 M77 anti-personnel mines). The cassettes are arranged inside the container so that, upon receiving an electrical impulse from the control panel, the mines are scattered across the terrain, forming a semicircle with a radius of 35 meters. They become operational 2 minutes after leaving the container.

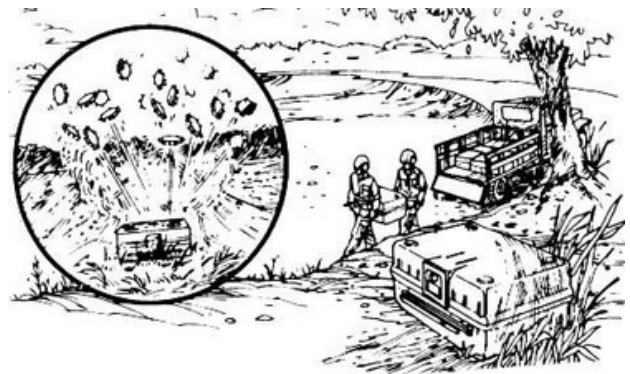

The container is carried by two soldiers. The required number of containers is deployed in advance on the ground according to a specific pattern. The minefield is created at the desired time. To do this, the operator issues a command to fire the mines from the containers. If a detonator is used as the MOPMS control unit, the mines' active duration is only 4 hours; if the M71 wired control unit is used, the operator can preset the desired active duration (4, 8, 12, or 16 hours) before the mines are ejected from the container; and if an M32 or M34 radio remote control is used, the operator can change the operational duration of the mines at any time, even after they have been deployed. Furthermore, in this case, the operator can neutralize the mines at any time via a radio command. Two minutes after the mines are ejected from the container, they assume their combat position.

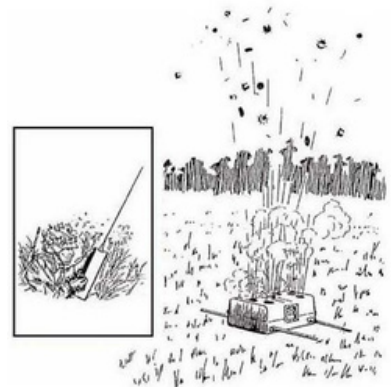

The mine's operational duration is 4, 8, 12, or 16 hours. After the operational duration has elapsed, the mines self-destruct. The mine does not have a non-retrievable element. The mine is non-disarmable and painted gray-green. There are no markings or inscriptions on the mine.

A significant drawback of the mine is that it must not fall onto hard surfaces (asphalt, concrete), as this may result in the destruction of the mine's casing or the failure of its mechanisms. When mines are laid in deep, loose snow (with a snow depth of more than 50 cm) or on marshy ground, many mines do not lie strictly horizontal with their flat side facing up. Since the mine has two cumulative craters (facing in opposite directions), it does not matter which side of the mine is facing upward. However, if the mine is tilted, the path of the cumulative jet increases, and the effective armor thickness increases. This reduces the mine's effectiveness. These mines are ineffective against tracks, as they merely punch a hole in the track.

Freezing of the power sources (when the ambient temperature is below -12 degrees) causes the mines to self-destruct. Attempting to use mines that have exceeded their shelf life causes them to self-destruct immediately after they are ejected from the cassette.

NOTE: *Operational experience with M78 mines in Iraq has shown that up to 20% of the mines do not self-destruct within the specified time. Numerous cases of mine failure due to overheating have been observed.*

The mine was deployed by the Armed Forces of Ukraine using remote-mining systems

**“PARM DM12/22” Anti-Vehicle Mine
(Germany)**



In 1997, the PARM DM12 mine—a modification of the PARM1—was adopted, which was already equipped with a SAPIR infrared sensor, which allows for precise firing of the rocket at ranges of up to 100 meters. It was subsequently upgraded to the DM 22. The PARM 2 warhead has been upgraded, with an armor penetration capability of 750 mm and the ability to penetrate reactive armor. The mine’s operational life is up to 40 days (up to 30 days for the DM 22). Furthermore, the mine can be repeatedly switched to a safe mode and re-deployed multiple times at the same or a different location, with a total operational life

of 40 days. This duration is determined by the capacity of the lithium power batteries. After replacing the depleted batteries with fresh ones, the mine can once again serve its full 40-day operational life, either in one continuous period or in segments.

Main Technical Specifications:

Housing material.....	aluminum alloy
Total weight.....	9.6 kg (without launcher)
Warhead weight (without grenade).....	5.94 kg
Grenade.....	3.66 kg
Explosive (hexogen, code R8020).....	1.26 kg
Grenade diameter.....	12.8 cm
Grenade length.....	49.8 cm
Warhead length.....	85.7 cm
Target sensor length.....	40/100 m
Effective range.....	2 to 40 m
Primary fuse.....	built-in
Armor penetration.....	up to 600/750 mm
Actuation force (optical fiber break force).....	approximately 5 kg
Disarmability/Retrievability	Yes/Yes
Self-destruction/Self-neutralization	No/No

Structurally, the mine consists of a warhead and a tripod mount

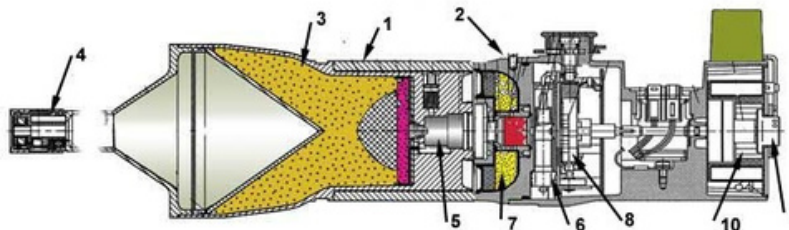

The warhead, in turn, consists of a cumulative grenade (1) and a fixed part (2), which remains on the mount after the mine is triggered. The projectile contains a charge (3) of hexogen with a cumulative cavity. In the nose section of the extension

tube is a piezoelectric generator (4), which generates a powerful electrical pulse upon contact with an obstacle (the target’s side).

It is electrically connected to an electric detonator (5) located at the base of the grenade.

If the fiber-optic cable is severed or pinched, an electronic circuit (6) located in the stationary part is triggered. This circuit sends an electrical pulse to the ejection charge (7), which propels the grenade toward the target.

This same stationary section also contains the timing mechanism (8) for arming the mine is also located in this stationary part.

Finally, at the end of the stationary section is the arming handle (9). A removable spool with the fiber-optic cable is also located there.

The mine is painted olive green.

The updated DM 22 mine also features more flexible adjustment mechanism. It can be adjusted in height from 30 to 70 cm.



Arming the mine.

1. Remove the mine from its packaging, ensure that the indicator on the top surface of the warhead points to the “S” position (“safe”), extend the mount’s legs all the way out, and place the mine in position.
2. Loosen the clamps on the launcher and bring the warhead into a horizontal position using the extension tube in the direction of fire. Secure the rear leg to the ground using the grounding rod.
3. Pull the reel with the fiber-optic cable out from the rear and unroll the cable in the direction of fire. Secure the reel to the ground and place a marker above it. Mount the optical sight on the launcher’s bracket and use it to aim the warhead precisely at the top edge of the marker. Ensure there are no obstacles in the grenade’s flight path and that there is at least 30 cm of clear space behind the launcher. Tighten the latches.
4. Turn the knob located at the end of the warhead from the horizontal to the vertical position. A green indicator light should flash on and remain lit for 16 seconds. During this time, the mine performs a self-test and the timer mechanism is activated. If the indicator does not light up or is flashing, the mine is defective.
5. After 5–6.5 minutes, the indicator on the top surface of the warhead will move from the “S” position to the “F” (“fine,” “fire”) position. The mine is now in the combat-ready position.



Putting the mine into a safe position.

Approach the mine at a 90° angle when performing any operations on it!!!

At any time during its operational life (within 40 days), the mine can be returned to the safe position; after that, it can be left in place or removed from its installation site and installed in a new location, and then returned to the operational position. This can be done repeatedly. However, each time the mine is returned to the combat position, its operational life will be reduced by the number of days it previously spent in the combat position (a plate on the mine indicates the “elapsed time”).

6. Insert the special key into the socket on the upper surface of the mine and, by turning it, move the indicator from the “F” position to the “S” position. As you do this, the handle at the end of the warhead will automatically rotate to a horizontal position. The mine is now in the safe position.
7. Wind the fiber-optic cable onto the spool, which should then be inserted into the end of the mine’s warhead.

Overall, the mine behaves quite peacefully and cooperatively. The only thing you should not do is tamper with the fiber-optic cable when the mine is in the armed position. It is very fragile and can easily be damaged if handled roughly.

Demining

Mines that are armed (with a live battery) are dangerous to bomb disposal experts. They may detonate if attempts are made to reposition or move them. It is safe to lift, move, or remove them only after the battery has been discharged. If a special key is available, you can carefully approach and deactivate them.

But even then, you must be aware of possible unexpected traps, such as those under or near the mine.

To defuse it, use a tray to place a TNT block with a fuse attached to a long rod or branch. Place block as close as possible without bumping the machine or the mine itself.

Shooting at it is dangerous. First, there is quite a lot of explosive material, and fragments of the casing can fly off and cause serious injury even to those standing to the side. Second, a terrible scenario could occur: the machine could be knocked off balance by bullet hits, causing the warhead to be launched toward the shooter...

The number of DM12 mines produced is unknown, while the number of DM22s is not that large—just over 13,000 in total. They are obviously not cheap. Production has been halted since 1998. After transferring a batch of 1,600 mines to Ukraine, Germany has been working to replenish its stockpiles and plans to launch mass production in the coming years.

Our military encountered the DM 22 mine as early as the beginning of summer during combat operations in the Kharkiv region.

PARM NextGen anti-tank mine (Germany)

In 2024, TDW introduced a new version of the PARM NextGen mine, intended both for



replenish Bundeswehr stockpiles depleted by aid to the Ukrainian Armed Forces, as well as for direct deliveries to Ukraine. The currently produced mine [the base version of the PARM] has undergone minor changes but remains the same system developed in the early 1980s. The PARM NextGen, which is set to replace it, differs primarily in its set of trigger sensors (vibration, acoustic, and infrared), which is installed in place of the original trigger cable. This has allowed for better target discrimination and an increased range.

In the basic version of the mine, the optical cable “detected” a tank moving above it and triggered the warhead, but could not determine how far away the tank was. Now, a new trigger sensor is integrated into the device in place of the original trigger cable.

The sensor is supplied by a third party. This innovation provides better target discrimination and also increases the weapon’s firing range, as it allows for determining the point of detonation upon firing—something the original optical cable could not do. The cable detected a tank moving overhead and

triggered the warhead, but it could not determine how far away the tank was. The new sensor solves this problem and allows the weapon to be triggered at the optimal moment.



The second feature implemented is remote radio control, which allows the PARM NextGen antitank mine to be activated and deactivated as needed, even multiple times. This gives the system maximum flexibility, as it enables the creation of an intelligent minefield. It will allow friendly military vehicles to pass through while subsequently blocking the advance of enemy units. Activating the mines at different times can also lure a convoy on the road into a trap, simultaneously striking both the lead and rear vehicles.

The remote control is designed in a form factor based on a personal



walkie-talkie, equipped with a short antenna with a range of “several hundred meters.” Each radio can interact with up to three mines. It is simple and has three main buttons: safe, arm, and fire; the latter disables the sensor’s automatic triggering function. Before operation, the mine’s safety pin must be inserted into one of the three slots available on the remote control.

The remote control is typically silent and transmits control signals only for very short periods of time, which, combined with low output power, minimizes the risk of detection and jamming.

This makes it possible to create an intelligent minefield in front of defensive positions that remains safe until the last friendly vehicles have departed, at which point it is activated to halt advancing enemy units.

Radio control makes it possible to lure enemy vehicle columns into a trap by activating the mines at different times, striking both the lead and rear vehicles.

The effective range of the PARM NextGen is 60 meters. The warhead is a 128-mm cumulative warhead from the base version of the PARM. The mine’s operational life is 30 days instead of 40, as the new sensor suite consumes more energy. After this time, the mine is not only deactivated but also becomes completely safe.

The mine has been tested in Ukraine and has proven its effectiveness. Mass production of the PARM NextGen is scheduled to begin in late 2026. For these batches, the company intends to introduce an upgraded version equipped with a radio-frequency data transmission channel, which allows for remote control over a greater distance (4 km). Remote control is used to arm or disarm the mine, allowing friendly forces to move along roads covered by PARM weapons.

F1 Anti-Vehicle Mine (MI AC AH F1) (France)

Anti-tank, anti-vehicle mine. The mine was adopted in 1969. As of 2008, it is the primary standard-issue anti-tank, anti-vehicle mine.

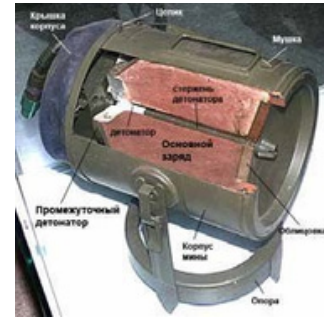

Technical Specifications of the F1 Anti-Vehicle Mine

Casing material.....	metal
Total weight	12.0 kg
Explosive charge (hexolite 65/35).....	6.5 kg
Diameter (mine body).....	18.4 cm
Length (overall).....	21.6 cm
Height of the mine when installed (overall).....	35.0 cm
Width of the deployed mine (overall).....	23 cm
Length of the linear target sensor.....	100 m (only 70 m is effective against the target)
Maximum target engagement range.....	80 m
Target engagement range with a 90% probability of hit.....	up to 40 m
Armor penetration.....	up to 70 mm of armor
Primary fuse.....	built-in electronic fuse with a target break sensor
Power sources	5 BA30 batteries (also known as 373, R20, "Mars")

or 5 NBA 3030 alkaline batteries

NOTE: When compared to the Soviet TM-83 mine of a similar type, the data provided in TTA150 and MAT2456 raise serious doubts. The French mine has a charge of 6.5 kg, while the Soviet one has 9.6 kg. The diameter of the cumulative crater created by the French mine is 18 cm, while that of the Soviet mine is significantly more than 20 cm. At a range of 50 m, the Soviet mine penetrates 100 mm of armor, creating a hole up to 8 cm in diameter. It appears that the French are somewhat overstating the capabilities of their mine. The mine's operational reliability at subzero temperatures also appears questionable.

The mine is laid perpendicular to the anticipated direction of movement of a tank or other armored vehicle, at a distance of no less than 5 meters from the path of travel. It strikes the vehicle's side with a high-explosive projectile at a range of up to 80 meters when the moving vehicle breaks the linear target sensor (a thin, low-strength two-wire cable).

The mine is deployed only on the ground and only by hand. It is placed approximately 2–5 meters from the edge of the target's path. The thin breakable wire (target sensor) is laid out in a zigzag pattern perpendicular to the direction of the tank's or vehicle's movement and secured to a peg driven into the ground outside the target's path.

At the same time, the wire along the path of travel is secured every 4 meters using special pegs driven into the ground (road surface). Thus, the sensor covers approximately 70 meters of the target's path of travel, even though its total length is 100 meters. In all cases, the mine must be installed so that the target is no closer than 5 meters to the mine. (*The 5-meter distance is dictated by the fact that, generally speaking, the mine is aimed at a vehicle moving quite far from the mine; if the vehicle is too close to the target, there is a risk that the projectile will pass under the vehicle's underside.*)

The danger zone extends 200 meters behind and 100 meters to either side of the mine.

Structurally, the mine consists of a metal (steel) cylinder filled with 65/35 hexolite (65% hexogen and 35% TNT) and sealed at one end. At the rear of the main charge is a hexogen or tetryl intermediate detonator enclosed in a casing.

The charge features a longitudinal axial bore lined with a tube. One end of the tube exits through the front copper lining, while the other extends beyond the rear wall of the casing. One open end of the tube has an external thread for screwing into the copper lining. Additionally, it has an internal thread for screwing into the detonator. The detonator holder, with a No. 8 detonator (detonateur pyrotechnique français No. 8 Briska—a complete equivalent of our KD No. 8A cap-detonator) secured at its end, is screwed into the tube.

The second open end of the tube is tightly fitted into the casing of the intermediate detonator. It terminates at the end wall of the housing. The detonator, when inserted into the tube, protrudes slightly beyond the wall, coming into contact with the electric igniter of the electronic detonator.

The liner, built into the front part of the casing, consists of a copper plate concave inward with a mass of about 2 kg. This creates a cumulative cavity. When the mine explodes, the copper liner forms what is known as a “projectile” or “piston,” which is a metal jet with quasi-liquid properties; traveling at a speed of about 2 km/s, it is capable of penetrating a layer of armor up to 70 mm thick at a range of up to 80 meters.

The mine’s cover is secured to the body by three box-type latches. Inside the cover are an electronic fuse and four batteries that power the mine. A cable extends from the cover to the outside, with two connectors at its end. One connector is intended for connecting the control line, and the other for connecting a break-type linear target sensor.

A 50-meter-long control line cable is connected to one of the two connectors on the mine’s cable. At the other end of the control line cable, there is a T-connector. A safety block is inserted into one connector, and the control panel is inserted into the other. As long as the safety block is inserted into the connector, the electrical detonation circuit is open and the mine cannot be detonated.

The control panel is designed to verify the proper functioning of the entire electric detonation circuit. It has its own power source (a BA30 battery). When connected to the control line simultaneously with the safety block, it allows you to check the integrity of the electric detonation circuit. To do this, remove the safety block. If the remote’s LED lights up within 2–7 seconds, the circuit is functioning properly. The remote performs no other functions. After verifying the circuit’s functionality, disconnect the remote from the control line (with the safety plug inserted!). The mine is armed and disarmed by removing and reinserting the safety block.

A spool containing 100 meters of thin, two-conductor break-away wire is connected to the second connector on the mine’s cable. After unscrewing the cap, you can pull on a special loop to extend the thin wire to the required length. This thin wire serves as a linear target sensor. When stretched and secured with pegs across the tank’s path, the electronic fuse is triggered if the tank’s running gear breaks the wire.

The electronic fuse consists of an electronic circuit powered by four BA30 batteries. When the mine is in the combat position, the storage capacitor is continuously charged by the batteries. When the target sensor is triggered, the electronic circuit connects the capacitor to an electric igniter, which detonates a No. 8 Briska detonator cap (a complete analogue of our KD No. 8A detonator cap). This detonates an intermediate detonator, which in turn detonates the mine’s main charge. The projectile formed by the explosion strikes the tank’s side. If a safety block or control panel is included in the control circuit, the storage capacitor cannot be charged.

If any malfunctions are detected or occur during mine deployment (premature failure of the target sensor, control line malfunction, etc.), the electronic circuit blocks the charging of the storage capacitor.

If the power sources fail during the mine’s operation (expiration, freezing, etc.), the mine becomes inoperable (self-neutralizes) because the capacitor cannot charge. However, if defusal procedures are performed, the batteries are replaced, and the procedures to restore it to operational status, the mine can function again.

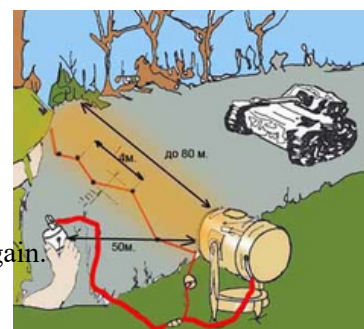

The time required for a single soldier to deploy one mine can range from 5 to 20 minutes, depending on terrain conditions, time of day, and level of training.

The mine is matte gray-green, gray-bluish, or dull gray-yellow **in color**.

Mine disposal procedure:

Mine neutralization is possible only if a control panel and a safety block are present. MI AC AH F1 mines installed in their standard configuration should be removed only after the mine and the surrounding area have been checked for booby traps; pressure-activated mines and tension-type target sensors may be used as non-removable elements.

1. Connect the control unit to the T-connector on the control line. The LED on the control unit should light up within 2–7 seconds.
2. Plug the safety block into the second connector of the T-connector.
3. Disconnect the target sensor from the mine cable.
4. Disconnect the control line from the mine cable.
5. Unscrew the detonator tube from the mine and disconnect the detonator from it.

NOTE: This description of the mine is intended for general informational purposes only and cannot be used as an instruction manual, as it intentionally omits certain important details and does not describe some key components.

This mine is used by Ukrainian fascists during combat operations in Ukraine.

F2 anti-vehicle mine (MI AC AH F2) (France)

The MI AC AH F2 mine is a further development of the MI AC AH F1 mine and differs from its prototype in that it can be programmed. The mine was adopted for service in 1999. As of 2016, it is the primary standard-issue anti-tank and anti-vehicle mine.



Through programming, the mine's operational duration can be set to either 30 days or a period ranging from 3 to 96 hours (in 1-hour increments), and the mine can be configured to either self-neutralize or self-destruct upon expiration of its operational duration.

If an operator manually activates the target sensor (a thin break-wire), the mine can be used in a controlled mode, although this mode of operation is not standard.

The main difference in the new mine is the cover, which performs many more functions compared to the prototype. Inside the cover are two PS 50 batteries and an ITS 120 electronic fuse. On the rear surface of the cover is a socket for a two-wire cable (target sensor). The rear surface of the cover, there are control elements, as well as displays and indicators for monitoring the mine's status. In addition, the rear wall of the cover features a socket for an electric detonator and an electrical connector for connecting the electric detonator to the circuit

of the electronic fuse.

The end face of the mine cover houses:

1. A coil with a breakaway cable, covered by a cap.
2. A socket for the electric detonator.
3. A connector for connecting the electric detonator wires.
4. An electric detonator cover.

In the "safe" position, the cover is closed.

The electric detonator is stored separately from the mine. It is placed in a case stored inside a group container.

In the "combat" position, the cover is also closed, concealing the electric detonator inserted into its socket and connected to the connector. This cover serves as

a key component of the mine's tamper-proof design, as any attempt to open it will cause the mine to detonate. The cover can be safely opened only when the mine is in the "safe" position or after the mine has self-neutralized.

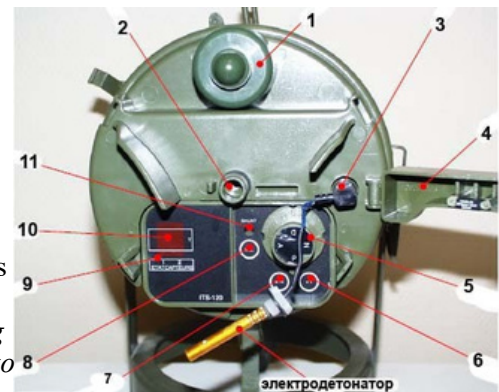

The mine control panel is painted black. It contains:

5. A four-position mine control knob.
 - Position **A**—the fuse is deactivated and the mine is in a safe state,
 - Position **N**—the mine is set for self-neutralization upon expiration of its operational life,
 - Position **D**—the mine is set to self-destruct after the end of its operational life,
 - Position **P**: the mine is in self-test and programming mode.
- 6 Operational life timer setting button.
 - Button for setting the tens place of the operational life.
- 7 Button to lock the values set by buttons 6 and 7.
 - Status indicator for sensors No. 1 and No. 2.
10. Alphanumeric display.
11. SHUNT indicator.

The display begins to flash and continues flashing for 4 minutes and 40 seconds, then goes dark. Twenty seconds after that, the mine is in combat mode. ***Any attempt to open the cover or move the mine from this point will cause it to explode.***

During combat operations, the mine cannot be removed or defused!



Structurally, the mine consists of a steel cylinder (1) closed at the front by a concave copper plate (2), which serves as the casing the cumulative cavity of the main explosive charge (Hexolite) (3). The rear part of the cylinder is sealed by a thin plate (4). In front of it, inside the cylinder, is an intermediate detonator (5).

The mine's cover is shown in pink in the figure; inside it are an electronic fuze, two power batteries, and an electric detonator (6) extending from the cover to the intermediate detonator. The cover is attached to the body by three box-type latches (7). The mine's control mechanisms are located on the outer end face of the cover. The cover is perhaps the only difference between the MI AC AH F2 mine and its prototype, the MI AC AH F1 mine. Even the holder for the detonator cap (8) has been retained; in the new mine, it is merely a vestige of the old mine and is not used in any way.

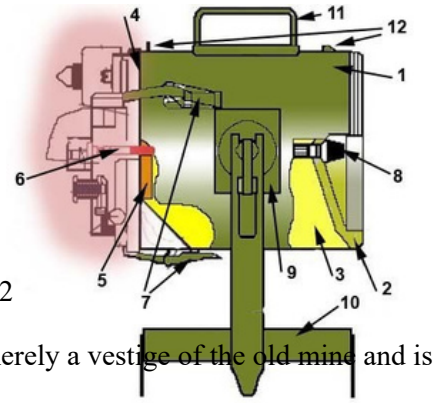

On the sides of the body are brackets for securing the body to a tripod base (10). These brackets allow the casing to be tilted up and down to aim the mine at the target. A carrying handle (11) is attached to the top of the casing, as well as a rear sight and front sight (12) for aiming the mine at the target.

The mine may be defused only under the following conditions:

1. It has reached the end of its operational life.
2. The control handle is in the **N** position

Procedure for defusing the mine:

1. Approach the mine from behind and ensure that the control handle (5) is in position **N** and that the SHUNT (11) is lit with a steady, even light. If the letters "FA" are displayed on the screen (10) and the status indicators for sensors No. 1 and No. 2 (9) are lit, this means that the self-neutralization process is in progress but not yet complete. When the status indicators for sensors No. 1 and No. 2 (9) go out, this indicates that the self-neutralization process is complete and you may proceed with the following steps to disarm the mine.
 2. Turn the control knob (5) to position **A**. The letter **A** will flash on the display (10) and turn off after 5–10 seconds. The mine is in a safe state.
 3. Open the cover (4), disconnect the electric detonator connector from the connector (3) in the mine cover, unscrew the electric detonator from the socket (2), and place it in the case.
 4. Disconnect the trip wire coil (1) and dispose of it.
 5. Detach the cover from the body and remove the batteries from the cover. Replace the cover on the mine body.
- This completes the mine disposal process.

If the control lever (5) is in position **D**, this means that the mine will self-destruct by exploding at the end of its operational life, and it cannot be defused. However, it is impossible to determine the mine's operational lifespan or the time of self-destruction. Such a mine must be destroyed on site by triggering an explosion. To do this, a pulley with a 30-meter rope is attached to the severed cable and pulled. Breaking the cable will trigger the mine's explosion.

This mine is also deployed by Bandera supporters during the Special Military Operation.

RK-14 / FORDONSMINA-14 Anti-Vehicle Mine (Estonia)

The Estonian RK-14 mine from Eesti Arsenal (photo on the left) was displayed in London in 2015.



The RK-14 mine was developed on an urgent basis under a contract from the Estonian Army, awarded to Eesti Arsenal in December 2014 and underwent successful testing from March through June 2015. The company has now been awarded a two-year contract to supply an undisclosed quantity of these mines to the Estonian Ministry of Defense...

It is a modified version of the Swedish mine FORDONSMINA 14 (photo on the right), which was also spotted with the Ukrainian Armed Forces (there is no data on their deliveries) and differs in that the RK-14 has a tripod for installation on the ground, various initiating devices, aiming devices, and a ribbed casing.

The FM14 anti-tank mine was developed for the Swedish Army in Finland by the Hackman Group.

Anti-vehicle side-impact mines with tension-type target sensors. Against tanks is not very effective due to the small charge weight of 1.5 kg. The diameter of the penetration hole, depending on the range (maximum), is approximately 31–39 mm. The effective range is up to 50 m, which generally coincides with the design specifications. However, the armor penetration depth specified in the Manual (60 mm) raises some doubts. Most likely, this applies at a range of no more than 5 meters. At the maximum range (50 m), calculations indicate that the mine penetrates no more than 20 mm. But this is usually sufficient for side armor.



Tactical and Technical Characteristics of the RK14/FM14

Mine Type.....	Anti-tank, anti-side, cumulative (high-velocity projectile)
Casing material.....	Plastic
Total weight.....	2.6 kg
Explosive (hexogen).....	1.5 kg
Diameter.....	15.5 cm
Thickness.....	about 12 cm
Target sensor.....	130 m shock-wave tube / tension wire
Penetration capability.....	Penetrates up to 60 mm of armor at ranges of up to 50 m; punch hole diameter up to 31–39 mm
Operational life.....	Indefinite
Time to deploy to combat position.....	immediately upon removal of the safety from the fuze. Fuze
.....	shock-wave tube/48 m tension-type
Defusability/removability	yes/no
Self-destruction/self-neutralization	No/No

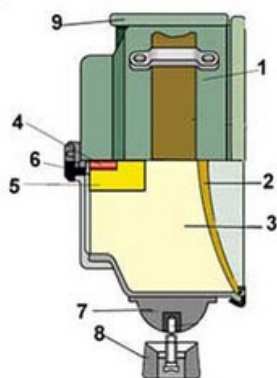

Structurally, the mine consists of a plastic cylinder (1) filled with a charge (3) of fused hexotol (a mixture of hexogen and TNT, known in our country as TG-50). The front end of the cylinder is sealed with a curved parabolic copper plate (2) 3–4 mm thick.

It serves as the lining for the cumulative cavity of the charge and acts as the material for forming the projectile core. The rear wall of the cylinder is integral with the body. In the center of the rear end wall is a hole, behind which there is a channel for the detonator (4). This channel is formed by drilling into a block of pressed hexogen (5), which serves as an intermediate detonator. The hole in the rear end wall is sealed with a screw plug (6).

At the bottom of the drum is a swivel head (7), which is used to secure the mine body to the bracket via a clamping head (8). At the top of the drum are slides (9) for mounting the sight.

The swivel head allows the mine body to be tilted up and down by 12 degrees from the horizontal and rotated left and right from the initial position by 180 degrees.

The clamping head (handle) locks the mine in place in the selected direction.

The mine is mounted on a G-shaped bracket nailed to a tree and secured with a strap so that the flight path of the projectile is perpendicular to the target's direction of movement. A distance of 5–30 meters from the road to the mine is considered optimal.

A range of 50 meters should be considered the maximum for reliably engaging the target.

The m/48 tension fuse (essentially equivalent to the Soviet MUV fuse) is secured below the mine body using a bracket included with the mine. The tripwire is stretched from the fuse across the target's anticipated line of travel so that its direction roughly coincides with the sight's line of sight, and is secured on the opposite side of the road to a local object.

The fuse and the mine are connected using a 2-meter length of detonating cord included in the mine's kit. A threaded detonator cap (which is screwed into the detonator) is attached to one end of this cord, and a detonator—which is inserted into a socket at the end of the mine's casing—is attached to the other end.

The base version of the PK14 is equipped with a 130-meter non-electric detonating cord (shock tube). Additionally, an electric cable and an interference-resistant radio detonator can be used for detonation. Development is continuing (?) on laser and thermal imaging sights, which will enhance operators' ability to assess the situation and increase the weapon's effective range.

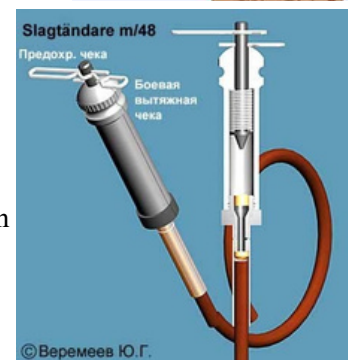
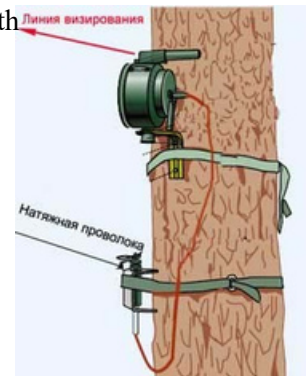

When the target (vehicle) pulls on the wire, the m/48 tension-activated fuse will be triggered and detonate the detonator cap inserted into it. The detonation travels along the detonating cord to the detonator inserted into the socket and initiates the mine. The resulting blast wave strikes the vehicle's side.

The mine kit includes two aiming devices. The mine itself is aimed using the so-called “coarse sight” (Originalsikte), which is a tube with openings at both ends. In other words, it is a type of diopter sight. It provides sufficient accuracy at ranges up to 50 meters.

The “fine sight” (Harkorssikte) is a plate with a hair-cross reticle that is mounted on the outer end of the coarse sight. This

sight is used by the operator when the mine is deployed in the guided mode. In this case, after the mine has been aimed at the target, the coarse sight is removed from it and taken to the control station. There, the plate with the hair-line crosshairs is attached to it. Through this sight, the operator determines the exact moment to detonate the mine in order to hit the target. The precision sight ensures accuracy at ranges up to 150 m.



Mine Color and Markings.

The mine is painted dark olive or dark green. It may have a camouflage finish.



fragmentation camouflage. The markings are painted on the front of the mine in the form of a yellow circle containing the number 14 in green paint. Below that are the year of manufacture and the manufacturer's code.

Packaging of RK14 / FM14 mines:

A box containing 8 mines—gross weight 43 kg / 37 kg. There are 9 boxes of mines on a pallet.

The marking on the end wall of the box is standard, in yellow letters:

- *supply item number,
- *supply designation of the mine (Fordonsmina 14),
- *number of mines in the box (8 pcs.),
- *manufacturer, lot number, and year of manufacture (on a single line).

**Inside the FM14 box are:**

1. Mine casings—8 pcs.
2. Individual packages containing initiation kits—8 kits.
3. Precision sights—8 pcs.

Each individual package for an initiation kit contains:

- *A locking key.
- *2 meters of detonating cord with a detonator and a nipple (with a detonating cap) at each end.
- *M/48 detonator.
- *A bracket for mounting the detonator with a strap,
- *Rough sight.
- *180 meters of tension wire,
- *Bracket for mounting the mine.
- *4 75-mm nails.
- *Strap for securing the mine bracket.

Disarmament

RK-14/FM14 mines installed in their standard configuration should be defused only after the mine and the surrounding area have been checked for booby traps; if defusal is not possible, destroy the mine on site using an explosive charge. To defuse the mine, remove the detonator cap from the mine.

The enemy may use mines equipped with Soviet MUV-series tension-type fuses or MVE MD-5m-series break-action fuses via an adapter sleeve.

These mines were discovered by our sappers during the special military operation in Ukraine in 2023.

TMRP-6 Multipurpose Mine (Yugoslavia)

The TMRP-6 antitank mine is designed to mine terrain against tanks and



other enemy armored vehicles. The mine was developed with Swedish assistance and was originally manufactured in Sweden, and later under license in Yugoslavia.



Technical Specifications of the TMRP-6 Mine

Mine Type.....	Anti-tank, pressure-activated, anti-bottom, anti-side.
Casing diameter.....	290 mm
Casing height.....	132 mm
Weight: total.....	7.2 kg
VV.....	5.1 kg
Actuation force: without pin, when pressed.....	150 kg
with a pin	1.3–1.5 kg on the tip of the pin, pin deflection angle 30°.
Armor penetration.....	from 40 to 80 mm at a distance of up to 80 cm and can be fired sideways from a distance of 45 m
Temperature range.....	from -25 °C to +50 °C

The TMRP-6 mine casing is round, made of plastic, and olive-green in color. Inside the casing is an explosive charge (trinitrotoluene mixed with tetryl). It is armed with a mechanical lever-type fuse, which is an integral part of the TMRP-6 mine and uses a penetrating warhead (penetrator).



Mine components:

- 1– carrying handle
- 2– pressure plate
- 3– recess for the sealing ring
- 4– UTMRP-6 fuse
- 5– inclined rod
- 6– arming button (shown pointing down)
- 7– winding cap
- 8– winding peg
- 9– clockwork mechanism
- 10– striking mechanism
- 11– steel ball
- 12– impact detonator
- 13– clearance fee
- 14– secondary detonator
- 15– explosive relay
- 16– auxiliary detonator

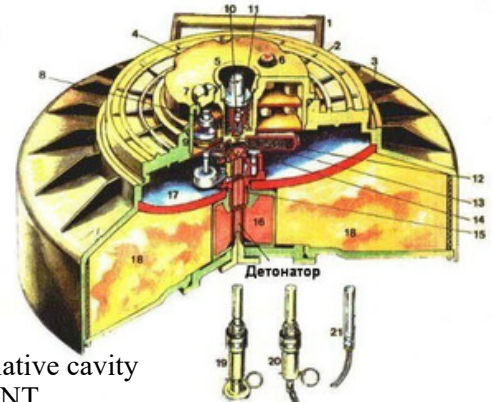

- 17 – cumulative cavity
- 18 – cast TNT
- 19 – UMOP-1 pressure relief safety device
- 20 – UMP-1 fuze that has been triggered
- 21 – M-67 electric detonator

UTMRP-6 detonator

The detonator is screwed into the center of the casing; it activates when pressure of 150 kg is applied to it. An optional accessory for the detonator is a metal rod that is screwed into it. If the rod is deflected to the side, an explosion also occurs.

The mechanical pressure-lever-type fuse is permanently installed in the shaft. It is equipped with a timer set to 1 or 4 minutes. The default setting is 1 minute. The detonator is activated by a pressure of 1,500 N or more. The mine can also be equipped with an additional detonator and can be electrically activated by a controlled shot.

The fuse can also be activated by a rod inserted into the fuse after the mine is set, with a force of 13–17 N (2–4 pounds). The fuse contains a propellant charge of black powder that destroys the weakened section of the mine's casing, ejecting the upper portion via an ejector pin, removing debris, and clearing the path for the penetrating disc to achieve greater penetration capability.



The original TMRP-6 variant had a mechanical fuse, but the improved version (TMRP-6E) features an electronic fuse on the mine's surface with a plastic casing, making it difficult to detect and neutralize. According to the developer, the electronic fuse allows for reliable target identification using magnetic and vibration sensors, while the mine's settings are controlled via an encrypted link to an external device. Advantages over the previous version include "the ability to map minefields via satellite, maximum effectiveness against targets, an improved algorithm to counter magnetic mine detection systems, and comprehensive mine status diagnostics."

The mine can be deployed manually, mechanically, or from helicopters. For manual deployment (a carrying handle is located on the side), a clod of earth half the diameter of the shaft is cut out, and a pit is dug so that the clod, 2–3 cm thick, protrudes 2 cm above the ground. The mine is placed in the hole, the safety element is removed, the fuse is set for 1 or 4 minutes, the trigger mechanism is activated (setting the fuse), and the mine is camouflaged.

The mine remains safe for 6 months even under very adverse conditions.



When used as an anti-vehicle mine, detonation of the charge creates a projectile from the metal disc, which strikes the target at a speed of 1,500–2,000 m/s. The impact core has sufficient energy to penetrate the hull of modern main battle tanks at a distance of up to 30 meters. The mine can be placed on the roadside with the pin facing sideways or in

remotely controlled version (wired) several tens of meters from the road.

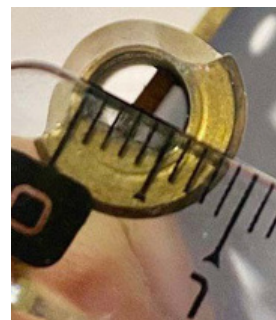
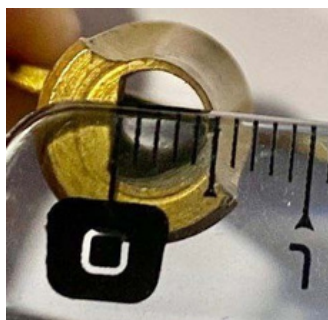

Mines may only be defused using the standard key or a copy thereof.

If the mine is damaged, deformed, the pin-type target sensor is blocked, or the key does not fit or turn, disarming it is prohibited, and such mines must be destroyed on site by detonation.

Mine Disposal

(These procedures are based on those described in the 1978 army manual "Yugoslavia")

Warning—any mine may be booby-trapped or equipped to detonate on command. Do not use radios near the mine. The wires leading to the electric detonator act as effective antennas. Only a small induced current is needed to trigger the detonator.

Circle the mine 360 degrees, checking for other mines and command wires.

If command wires are found, trace them to the detonation point; if you have disrupted the booby-trap circuit, and if it is safe to do so, separate the two wires and cut them one at a time, then insulate the cut ends.

1. Carefully remove the cap from the top of the mine only.
Do not move the mine or the inclined rod, if present.



2. If an inclined rod is installed: hold the mine steady with one hand, grasp the base of the inclined rod, and lift it straight out of the hole without any sideways movement.



3. Locate the carrying handle, attach a rope to it, and pull the mine (move it from its installation site) from a safe shelter to a safe distance. Wait a few minutes (pull the rope several times). If the mine does not explode, conduct a visual inspection to check for any on the mine that may not have detonated, and, if such a device is present, destroy the mine on the spot using an overcharge.

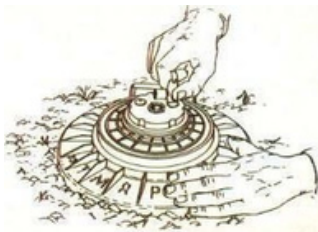

4. Examine the mine, remove the protective cap from the arming keyhole; if you deem it safe, perform the disarmament procedure. If you have the key, unscrew the key cover with the wide end (or use a wide screwdriver).

5. Insert the key into this hole, aligning the notches, and turn it counterclockwise (in the direction of the arrow marked on the push plate) until the arming button pops up. Lock the button in the up position; remove the key; the device is now safe. (Or try turning the key lock with long-nose pliers—if this fails, destroy the mine on the spot with an explosive charge.)



6. If a safety device is available, place it on the slanted rod and turn it clockwise until the tab is positioned under the arming button to prevent accidental arming. The mine is now safe. (A V-shaped wedge is provided as an alternative.)

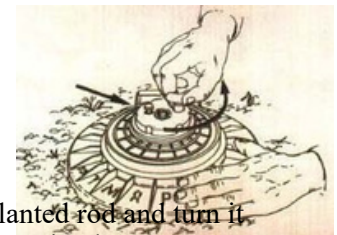

Unscrewing the fuse may cause the mine to explode!

The mine is used by Ukrainian Armed Forces units during the special military operation.

RT Mi-U Universal Mine (Czech Republic)

The RT Mi-U anti-tank mine is designed for mining terrain to destroy enemy combat and other equipment through combined action, depending on the type of



fuse (target sensor): with a pressure-sensitive target sensor—it acts as an anti-track mine; with a pin-type target sensor—it acts as an anti-bottom mine. Developed in the late 1980s.

PT – anti-tank. Mi – mine. U – universal, implying the ability to use various types of fuses. They come in three configurations, with fuses and target sensors of different types:

- a) mechanical with pressure-activated target sensor;
- b) mechanical with a tilt-activated target sensor;
- c) electromagnetic non-contact.

So far, only the first two variants have been included in deliveries to Ukraine, as they are older and less expensive. Externally, the mine closely resembles the Yugoslav TMRP-6.

Tactical and technical characteristics:

Casing material.....	plastic;
Weight: mines.....	9.5 kg;
Explosive (TG-50/50).....	7.1 kg;
Size: diameter.....	320 mm;
top cover diameter.....	110 mm;
Height (with detonator).....	128 mm.
Fuse activation force: on the target pressure sensor.....	150 kgf;
with a pin-type target sensor.....	4–15 kgf;

Supplied fully assembled with the fuze.

Fuse remote arming mechanism.....	pneumatic;
Remote arming time.....	from 1 to 10 minutes;
Operating temperature range	-30 to +40°C

The PT Mi-U mine is a disc-shaped projectile resembling the familiar form factor of the most popular

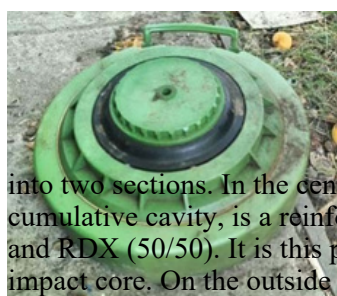

TM-62 antitank mines. It is a dual-action mine capable of functioning as both a high-explosive and a shaped-charge mine. The second mode is achieved through a concave liner that forms a projectile core, which more effectively penetrates the bottom of armored vehicles.

The mine's casing is made of plastic. The explosive charge is divided into two sections. In the center, corresponding to the size of the cumulative cavity, is a reinforced charge consisting of a mixture of TNT and RDX (50/50). It is this part of the charge that forms the anti-bottom impact core. On the outside the central charge is encased in a ring of pure TNT. This part serves as a supplement to enhance the explosive effect when the mine functions as a pressure-activated mine, and is designed to tear apart a track or destroy a vehicle's wheel through blast action.

The fuse is a mechanical-action fuse with a pneumatic main detonator. The fuse is hermetically sealed inside the mine using a rubber ring to prevent moisture ingress. On the pressure plate of the detonator, there is a button for arming the mine, which is locked in place by a plastic lever. This lever, in turn, is secured by a metal safety pin.

The button has a threaded hole for screwing in a pin-type target sensor.

1. Spring.
2. Combined delay fuse.
3. Fuse housing.
4. Fuse mechanism.
5. Firing pin.
6. Balls.

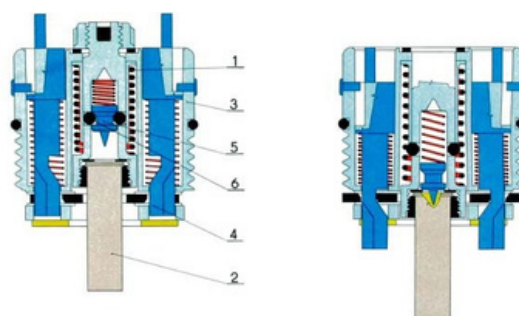

The operating principle is intuitively clear from the diagram. Pressure is applied to the target's pressure sensor. The strength limit of the stops is exceeded, and they break. Via the pins, the inner part—the detonator mechanism—is pushed downward, overcoming the resistance of the springs that held the assembly in its initial position. The balls reach the holes, are pushed to the sides, and the spring-loaded striker, now released, strikes the primer. This initiates the detonation of the booster charge, followed by the main charge.

Installation in the anti-tank variant

Remove the protective cap from the fuse, remove the safety pin, slide the safety key insert off the fuse, insert it into the fuse's opening, turn it clockwise until it locks in place, unscrew the key while holding the fuse with your hand; the delayed-action mechanism is now activated. In 1–10 minutes, the mine will be armed, and pressing the cover will trigger the explosion.



Removing the safety pin



Removing the key insert.



Setting the detonator to the live position



Sequence of steps for mine installation:

1. Dig a hole to fit the mine's dimensions, to a depth reaching the lower edge of the rubber ring (with the pressure disc above ground level).
2. Place the mine and conceal the carrying handle.
3. Remove the safety pin.
4. Release the transport lever.
5. Remove the cap from the button and screw the threaded part of the transport lever into the button.
6. Use the lever to press the button all the way in.
7. Remove the lever from the button and camouflage the mine.
8. After installation, hand over the lever and safety pin to the commander.



Transport position



If the button is not pressed in, the device is not cocked



Firing position

Version with an inclined sensor (anti-bottom)

The RT Mi-U anti-tank mine is considered versatile, as it can be used as an anti-track or anti-bottom mine (for this purpose, pressure-activated or pin-type mechanical fuses are used). It has a directional warhead (of the



"impact projectile") and is designed for manual or mechanized deployment. To ensure the required effectiveness of the impact core charge generated by the explosion, the mine is equipped with a cover-blasting charge, which, prior to detonation, blows off the cover (which encloses the main charge) along with the layer of camouflage soil on it.

The PT Mi-U mine with a cover for mounting an inclined target sensor (pin). If the pin is not installed but the mine is armed, the cover functions simply as a pressure sensor.

1. Pin.
2. Movable cap.
3. Firing pin.
4. Threaded safety plug. (Removed before installing the tilt sensor into the fuze.)
5. Spring.
6. Balls.

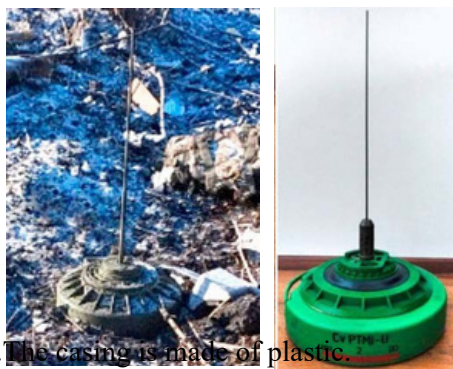
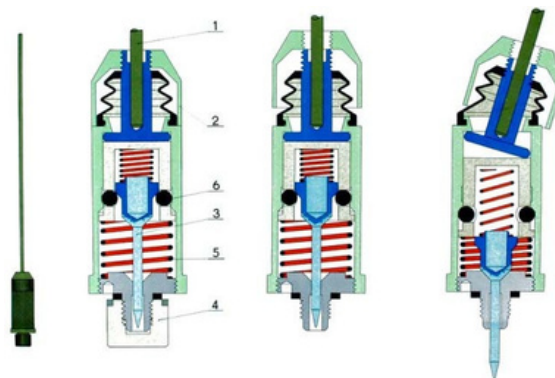

If you apply force to the top of the pin, it acts as a lever. It bends the rubber bellows holding it in place quite easily. The rod tilts and, with its wide base, pushes the actuator downward. The balls pop out through the side slots, releasing the striker. Thanks to a powerful spring, the striker strikes the internal detonator's actuator, pushes it downward, and triggers the detonation process in the same way as the pressure sensor did.

1. The casing is made of plastic.
2. Explosive: the outer ring is simply TNT.
3. Explosive, core—TNT and hexogen (50/50).
4. Intermediate detonator made of compressed TNT.
5. Internal detonator mechanism.
6. Detonator.
7. Intermediate ejection charge, in the form of a washer or a tablet with a hole.
8. Protective washer. To prevent the detonator at the bottom from being prematurely triggered by the ejection charge.
9. Fuse cover (pressure-sensitive target sensor, if a pin is not used).
10. Spring of the remote arming mechanism.
11. Remote arming mechanism button.
12. Detonator cap shutter (to prevent it from being triggered by an intermediate detonator).
13. Compressed-air bellows (5 pieces).
14. Safety block.
15. Inclination target sensor (pin).

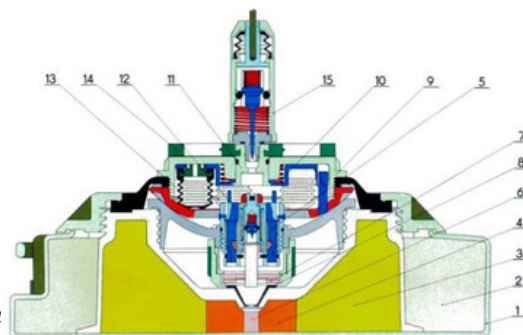

To install the device with the tilt sensor, unscrew the plug from the hole in the center of the cover. Screw the sensor pin into the hole. Place the mine in the hole and camouflage it. Only then remove the pin and safety block, and press the button through the sensor pin while holding it by the base, thereby activating the remote detonation mechanism.



Safe Position



Combat position

Sequence of steps for laying the mine:

1. Dig a hole to fit the mine's dimensions.
2. Place the mine and conceal the carrying handle.
3. Remove the cap from the button and screw in the pin-type target sensor.
4. Remove the safety pin.
5. Release the transport lever.
6. Using the pin-type target sensor, press the button all the way in.
7. Unscrew the safety sleeve on the pin-type target sensor without removing it.
8. After installation, hand the lever and safety check over to the commander.

The remote arming mechanism operates for 1 to 10 minutes (depending on temperature), after which the mine enters the combat-ready position. With a pressure sensor, this is not as critical; it is highly unlikely to accidentally apply 150+ kg of pressure. However, if the top of the pin is touched, even a very small amount of force is enough to trigger the explosion.

The remote arming mechanism operates on a pneumatic principle. Under the mine's cover, there are five bellows filled with compressed air. After the safety pin is removed and the mechanism is triggered, they begin to deflate. When they finish deflating, the firing pin is released. The mine is then in the armed position.

Mines with older pressure-sensitive or tilt sensors do not have a self-destruct mechanism.

Variant with a non-contact electromagnetic sensor



The electromagnetic sensor is both contact and non-contact. That is, it can be triggered either by the approach of a large mass of iron or, like a conventional pressure-sensitive sensor, by contact with a track or wheel. The mine can be used with an electronic fuse featuring an adjustable electronic arming delay, self-neutralization period, and self-destruction period.

The external differences from a standard pressure-activated mine are negligible when the pin and block are removed, which generally makes identification more difficult.

There is also a slot visible on the side for installing an additional trap detonator, a feature absent from earlier versions of the mine. Although this can be done by hand, simply by drilling a hole and inserting some kind of detonator...

This type of sensor is the most dangerous because it is inherently non-removable.

Any attempt to interact with the mine—moving it, lifting it, or even approaching it with a metal detector—will trigger it.

It also has a self-destruction function. The time is set during mine installation by selecting the positions of the remote detonation mechanism's trigger button. There is a slot on top of it for a special key (*which can be replaced with any suitable flat tool*).

If the mark on the button aligns with the mark on the fuse cover, the timer is set to the maximum duration—30 days.

If, without removing the pin, you turn the button with the key to:

- 90 degrees clockwise—17.5 days.
- 180 degrees – 10 days.
- 270 degrees – 1 day.

Then the pin is removed and the button is pressed in, activating the remote arming mechanism.

When a vehicle attempts to drive over the mine, it explodes beneath the vehicle's bottom and penetrates it with a cumulative projectile. If a track or wheel strikes the mine, a simple high-explosive blast occurs without a cumulative effect.

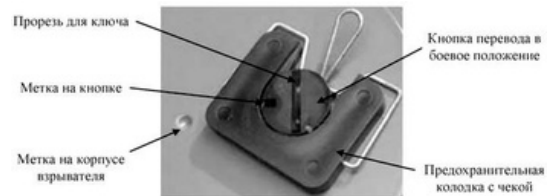

PT Mi-U Mine Activation

Whether triggered by pressing the target sensor or by deflecting the pin, the stops are broken, causing the spring-loaded striker to release. It pierces a combined primer with a delay element. First, a small charge of explosive—the tablet beneath the fuze—detonates. It propels the fuze mechanism, the cover, and the camouflage elements upward. This is necessary for the shaped-charge projectile to form correctly and achieve maximum effectiveness. At the same time, the delay-fused cap is well protected, and the initial upward-directed explosion of the small charge does not damage it. 0.1 seconds after the first charge detonates, the delay-fused cap transmits the flame impulse to the intermediate detonator at the bottom of the mine, which then initiates the main explosive charge.

Defusing:

Mine disposal is carried out in reverse order, depending on the type of installation. It is not possible to return the mine to its transport position; theoretically, the fuse can be unscrewed, but a special wrench is required. Therefore: destroy it with an overlying charge. There is no point in removing it.

The mine is used by the Ukrainian Armed Forces during combat operations.

SLAM M2 and M4 Multipurpose Light Ammunition (USA)

A multipurpose, small-sized mine adopted by the U.S. Army Special Operations Command in 1994.



The mine's primary purpose is to destroy lightly armored vehicles, aircraft at airfields, ammunition depots, etc. The mine's relatively high destructive power combined with its small size and light weight make it a very convenient tool for setting up ambushes on roads and carrying out sabotage operations.

It is also noted for its effectiveness in capturing prisoners in situations where the use of more powerful anti-tank munitions could not only damage the vehicle but also destroy what the reconnaissance team needs inside it.

The M2 round was developed specifically for Special Operations Forces (SOF) units. Engineering units and other branches of the military do not use this round. It is painted entirely green.

The M4 round is designed for light infantry, airborne, and air assault units, as well as rapid deployment and crisis response units. The warhead is painted black, and the rest of the round is painted green.

It can be used in as an anti-tank, anti-hull magnetic cumulative mine, as an anti-tank side-impact cumulative mine; as a target-specific mine designed to engage



by a cumulative jet and an impact projectile, triggered by a delayed-action fuse or by command from a control panel

Essentially, the munition is a scaled-down model of an anti-tank side-impact mine similar to the Soviet TM-83, the Swedish Type 14, or the French MAH mod. F.1. The mine's multi-purpose nature is due to its universal fuze, which features magnetic and infrared sensors, a timer, and an impact fuse.



Technical Specifications of the M2 and M4 Munitions

Casing	Metal
Mode of Action.....	impact projectile.
Weight: mines.....	998 g
Explosive (LX-14 contains 95.5% octogen and 4.5% plasticizer).....	280 g
Fuse.....	built-in/electric detonator
Target sensor types.....	magnetic, passive infrared, timer
Ammo dimensions: length.....	13.2 cm
width.....	8.9 cm
thickness.....	5.6 cm
Armor penetration at a distance of up to 7.6 m.....	40 mm
Armor penetration at a range of 13–52 cm.....	20 mm
Timed detonation.....	after 15, 30, 45, or 60 minutes
Installation.....	Manual only.
Installation depth underwater.....	up to 2 m
Operational duration when using a magnetic target sensor	
4, 10, 24 hours (the infrared sensor must be covered) Operational	
duration when using an infrared target sensor	
4, 10, 24 hours (the magnetic sensor is not covered)	



Principle of operation and design:

The target is destroyed when the mine detonates using a projectile.

The mine is equipped with a universal fuse featuring a magnetic sensor, a passive infrared sensor, and an electronic timer that initiates detonation after 15, 30, 45, or 60 minutes. In addition, a remotely controlled version using M6 electric detonators is available. The mine is equipped with a safety mechanism that interacts with the arming lever on the front of the casing.

It is available in the following main variants:

-**M2** (for special operations forces) with a self-neutralization device, painted entirely green with a black warhead. Intended for use exclusively by SOCOM units;

-**M3** (for special operations forces), a guided variant.

-**M4** and **M4E1** (for the Army) with a self-destruction mechanism, painted green with a black metal charge casing cone. Intended for use by airborne and air assault units, rapid response units, and rapid deployment forces.

General design:

1. mounting holes for the mine;

2. open-sight aiming devices;

3. a selector switch. It has 8 positions:

- 1—safe;

- 2, 3, 4—correspond to 4-, 10-, and 24-hour modes. In these positions, the switch sets the self-neutralization or self-destruction time when the mine is used in “side-attack mine” and “bottom-attack mine” modes

- Positions 5, 6, 7, and 8 correspond to intervals of 15, 30, 45, and 60 minutes when the mine is used as a target mine.

4. A shear pin for switching to controlled mode.

The switch lever passes beneath the pin. When the lever is raised, the pin is severed and all mine sensors are deactivated. From this point on, detonation is possible only via an electric

detonator.

5. Ring of the lever for switching to controlled mode.

6. Lever for switching to controlled mode.

7. Safety pin. Removing it starts the delay timer. Once the pin is pulled out, it cannot be reinserted.

8. Passive Infrared (PIR) sensor.

9. PIR cover.

10. Socket for the electric detonator.

11. Metal cone for forming the projectile.

12. Housing.

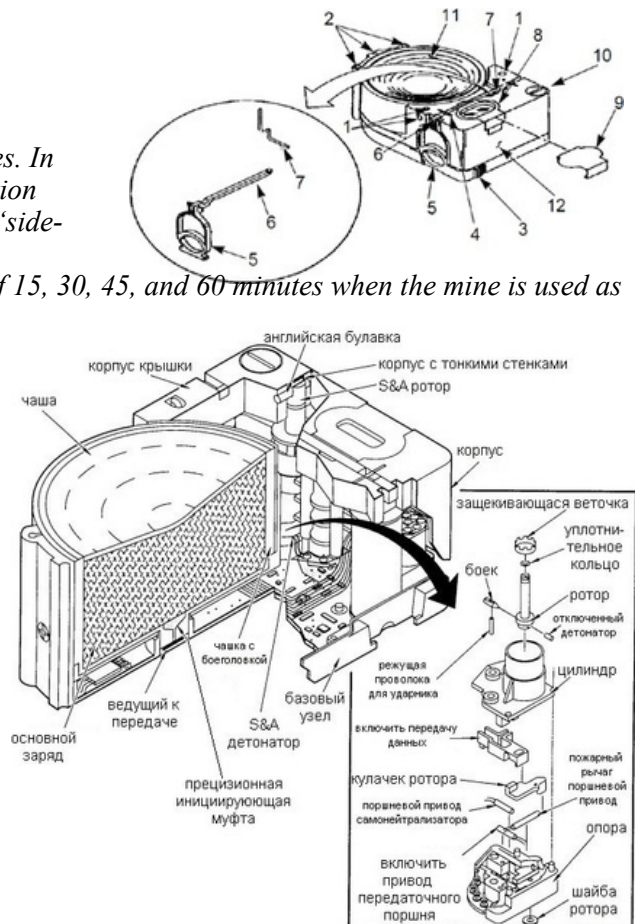

Mine operating modes:

1 OPTION *Use of the mine as an anti-tank mine.* The mine is placed on the ground with the cumulative funnel facing upward. The magnetic sensor is active, and the passive infrared sensor is covered by a cap. The mine's operational time is set to 4, 10, or 24 hours, after which the self-destruction/self-neutralization system renders the mine safe (M2) or detonates it (M4). The mine detonates when a vehicle passes over it. Camouflage with dry leaves or grass is permissible, but care must be taken to ensure that rocks, dirt, or water do not fill the cumulative cavity; otherwise, this will negatively affect the formation of the impact core. The minimum distance to the target at which the impact core is already partially formed is 13 cm.

2 OPTION *Use of the mine as an anti-vehicle mine.* The magnetic sensor remains activated but does not participate in the operation. The mine is placed on the side of the road with the cumulative crater facing the road. Aiming is performed using the open sights on the top face of the mine or via the laser sighting unit. The cover is removed from the passive infrared sensor, and it reacts to a change in temperature (thermal radiation emitted by the vehicle's engine) and detonates the mine. Unlike an active infrared sensor, a passive infrared sensor does not require a receiver device or a mirror to reflect the beam. The mine's operational time is set to 4, 10, or 24 hours, after which the self-neutralization mechanism either renders the mine safe (M2) or detonates it (M4).



3 VARIANT *Use of the mine as a delayed-action anti-structure mine.* The mine is deployed against a target similarly to an anti-hull mine, or on or under the target similarly to an anti-bottom mine (directing the cumulative cone toward the target). The timer is set for a delay of 15, 30, 45, or 60 minutes, after which the mine detonates.

4 OPTION *Use of the mine in a remotely detonated variant.* The mine is set up similarly to the previous method, but the detonation is carried out by a miner from a safe distance using a mechanical or electrical detonator attached to the percussion primer.

When the mine is set using a special lever, the shear pin is broken; after that, detonation is possible only using M6 and M7 electric detonators (radio-controlled detonators may also be used).

Soviet- or German-made electric detonators are not suitable for detonating this mine due to their smaller diameter.

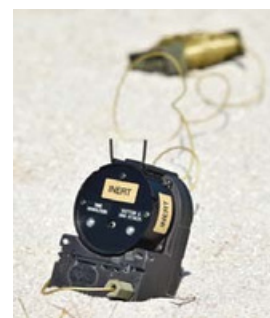

The mine cannot be defused in "anti-side" or "anti-bottom" modes. An explosion occurs when an attempt is made to set the mode selector switch to the "safe" position. However, in principle, the mine remains removable in "bottom-mounted" mode. It can be removed from its installation site and carried away, but it cannot be rendered safe. In "side-mounted" mode, approaching the mine is dangerous, as the infrared sensor can detect human body heat at close range.

Disarmament:

The mine has no built-in mechanisms to prevent removal; however, in "side-attack" and "bottom-attack" modes, it cannot be defused. An explosion occurs when an attempt is made to set the mode selector switch to the "safe" position. However, in principle, the mine remains removable. It can be removed from its installation site and carried away, but it is impossible to render it safe. In the "anti-side" and "anti-bottom" modes, approaching the mine is dangerous, as the magnetic sensor may react to metal parts of equipment, and the infrared sensor may react to human body heat at close range. It appears that factors such as these were the cause of two accidents involving the handling of the mine, which were investigated by a commission of the Special Operations Forces Command. No fault on the part of the manufacturer was established.

Inthespringof2024,theminewerediscovered byoursappersduring military operations in Ukraine.

M49A1 Signal Mine (U.S.)

This is a light-and-sound mine that is set on a tripwire; when triggered, it produces a large flash and continues to burn for some time, thereby signaling the presence of the enemy. When the mine is triggered, 12–15 light “stars” are ejected from the casing, and an audible signal is generated by pyrotechnic.



Depending on the configuration, the signal flare can be activated by releasing the trigger or removing the safety pin in the same manner as the safety pin on a hand grenade.

When using a tripwire signal flare (TPW) or a booby trap (BTP), each device is a wire 15m, which attaches to the trigger, and the signal flare can

be fired at a minimum pressure of 900 g.



Main Technical Specifications

- Mine Type.....Light-and-sound
- Mine weight.....0.4 kg
- Casing material.....metal
- Filling 12–15 stars (pyrotechnic mixture)
- Dimensions.....25 × 278 mm

Cutting or damaging the TPW will also trigger the signal flare. The signal flare ignites instantly (INST) and provides bright illumination, with a flame approximately 1 m high and a brightness of 35,000 candelas for approximately 1 minute.

General design:

The mine consists of an aluminum casing and a cover assembly containing the firing mechanism. The firing mechanism consists of a hinged striker, a lever, a safety clip, and a retaining ring. It is equipped with a U-shaped mounting bracket and is installed by nailing or clamping it to any pole, post, or other vertical object.

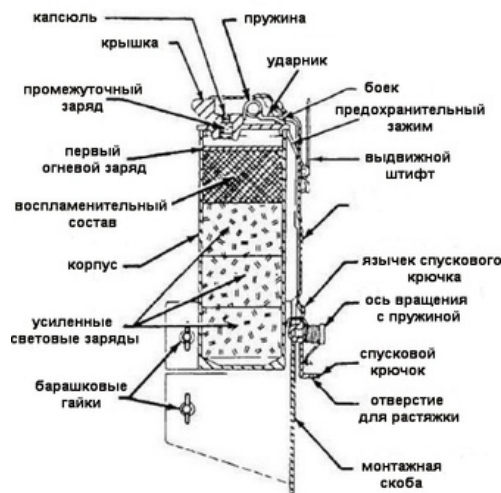

Instructions for use:



Loosen the screws and remove the mine the housing place



Turn the lever and secure the mine to with a screw so that the bracket is held in only by the lever



Install the mine and the target sensor. The sensor is secured in the "eye" of the lever



Remove the safety pin; the target

The mine is used throughout the entire LBS with the Ukrainian Armed Forces

161
M 142 (USA)

The M142 multifunctional trap fuse is designed for setting explosive traps triggered by pressure, removal of a load, tension, or cutting of a tripwire.



Main Technical Specifications:

Fuse weight.....	34 g
Dimensions: length.....	57 mm
Width.....	40 mm
height.....	28 mm

Actuation force from pressure.....	11.3 kg
Tension activation force.....	3.2 kg
Minimum load weight when installed for load relief.....	1.1 kg
Minimum force when set to release tension.....	1.1 kg

The detonator consists of a plastic housing with a striker and a main spring, a firing lever, a sleeve with an ignition cap, and a clamping sleeve for the detonator cap, a safety pin, a round-headed pin, and a square-headed pin. The housing features tabs for attaching the detonator to objects.

The kit includes: a 15-meter wire tensioner, nails, screws, a spring-loaded lever, and installation instructions.

In the transport position, the firing pin protrusion fits into the firing pin's annular groove, holding it in cocked position. The safety pin passes through the striker's travel channel, blocking it. The detonator can be installed in four modes: pressure, tension, unloading, and break (cutting the tension wire).



Installation procedure:

- 1) Place the explosive charge or mine that is to be initiated by the explosion at ;
- 2) Arm the detonator with a detonator cap by placing it on the nipple of the sleeve containing the ignition cap and securing it with a clamping sleeve;
- 3) Secure the detonator in the desired location using fasteners;

Next, depending on the installation option, do the following:

- a) **For the push-type installation**—remove the square-head pin, leaving the round-head pin in place;
- b) **For the tension-type installation:** stretch the tension cable by attaching it to the hole at the rear of the firing lever, then remove the square-headed pin, leaving the round-headed pin in place;



- c) **For the unloading configuration**—place the weight on the firing lever, then remove the round-headed pin;

- d) **For the version with a tension cord**—insert the spring lever into the hole at the rear of the firing lever, attach the tension cord to its free end, then remove the round-headed pin, leaving the square-headed pin in place.

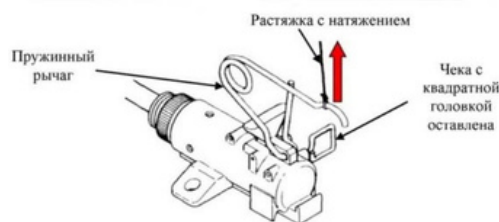

- 4) Remove the safety pin;
- 5) Camouflage the fuse.

Upon any type of impact, the firing lever rotates on the remaining pin (with a round or square head) as if on an axis; the lever's protrusion disengages from the firing pin, and the firing pin is released, striking the primer. If the tripwire is cut, the spring-loaded lever compresses and, through its mass, provides the force necessary to move the firing lever.

The “ ” fuse is used by Ukrainian Armed Forces sappers when mining various objects.

**RO-4 Trap Fuse
(Czechoslovakia)**

The RO-4 trap fuse is a pressure-activated fuse designed



for setting anti-tank mines in a non-retrievable position and for setting explosive traps. The RO-4 consists of a plastic housing, a threaded sleeve for attaching the fuse, a striker with a spring secured by a safety pin, and



a discharge rod covered by a rubber cap. It is used with a ZK fuse and an additional charge of explosive.

The fuse does not have a remote arming mechanism. In the transport position, the striker is held in the cocked position by the safety pin. When a charge is placed on the discharge rod, the striker lowers and its conical

base blocks the striker's path. After the safety pin is removed, the striker rests against the base of the discharge rod. When the charge is removed, the rod is pushed upward by the striker against the conical base, releasing the striker, which strikes the primer of the fuse.

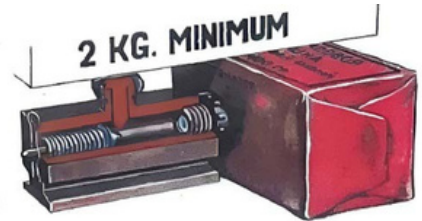

Tactical and Technical Specifications:

Dimensions: length.....73 mm
width.....25 mm
height.....51 mm

Long-range cocking time.....None.
Minimum payload.....2 kg
Stem travel before actuation.....2 mm.



SU-24-M.83 Delay Fuse (Yugoslavia)

Designed for demolition and sabotage operations. Can be used with both standard high-explosive charges and landmines and hand grenades. The fuse measures 87 mm in length and 70 mm in diameter.



The delay time ranges from 15 minutes to 24 hours.

The casing is made of green plastic. The casing has a thread that allows the fuse to be screwed into the ignition sockets of anti-vehicle mines, such as the TMA-1, TMA-1A, TMA-2, TMA-2A, and TMA-5.

The internal thread of the brass fitting allows it to be attached to hand grenades.

The time-setting ring is covered with green plastic and has 24 markings, evenly spaced at time intervals, with an arrow indicating the direction of rotation.

Sealing rings on the threaded sections of the mine's body and cover ensure a watertight seal.



This fuse was discovered on an enemy sabotage and reconnaissance group in the Kursk sector in 2025.

MPR-M85 Target-Activated Magnetic Mine (Yugoslavia)

The Yugoslav MPR-M85 is a round, object-activated high-explosive adhesive mine equipped with an delayed-action fuse (ETF), is a plastic, magnetic mine designed primarily for land-based sabotage missions, although it can be used underwater at depths of up to 10 m and contains 400 g of plastic pentrite (PEP)—an explosive based on a heating element. The total weight of the mine is 1,600 g.



The mine is made of plastic with a semicircular metal plate held in place by magnets on the base, which can be used to cover the lamps at the bottom.

The mine's base contains two round magnets (for attachment to steel surfaces), a slide switch for turning the device on and off, a piston that prevents removal

(ARD), a waterproof battery compartment, and three red LEDs.

Before installing the MPR-M85 in place, the electronic delay (DLY) is set manually to 15 or 30 minutes, followed by 1, 2, 4, 8, and 16 hours.

After setting the DLY, the safety pin is removed, and after 7.5 minutes, the fuse enters the armed state.

After the MPR-M85 is armed, a fuse with an anti-tamper device (ADD) is installed to prevent its removal.

Upon detonation, the mine's main charge can penetrate up to 15 mm of steel plate.

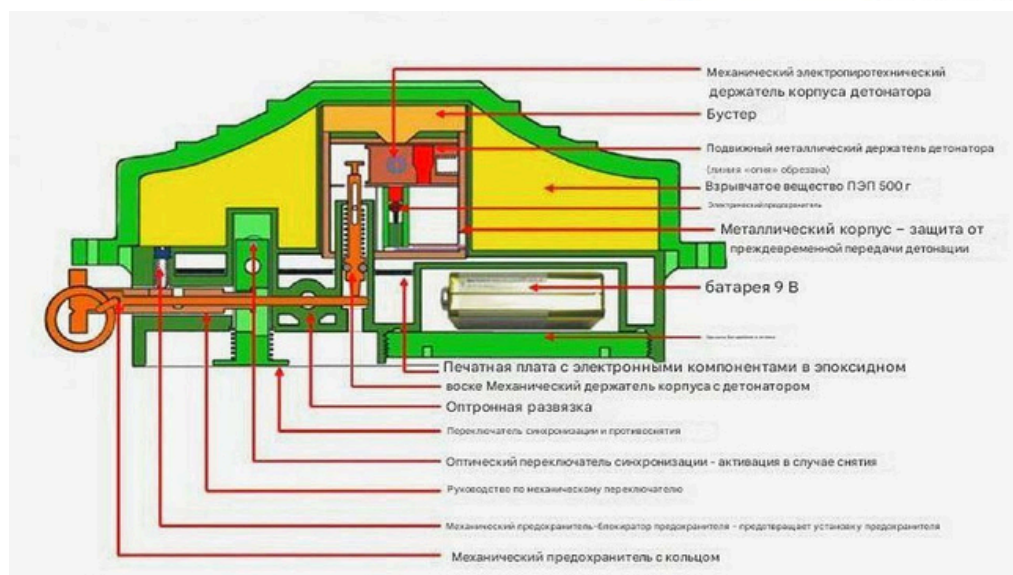

This mine was discovered with an enemy sabotage group in the Kursk sector in 2025.

“Kirpich” anti-personnel trap mine (Ukraine)

Open-source materials rarely provide detailed descriptions of atypical, camouflaged munitions designed not only for frontline combat,

but also for sabotage, subversion, and covert strikes. As early as August 1864, Thomas Courtney devised a way to blow up a ship using an explosive device disguised as a piece of coal. The history of Thomas Courtney’s coal mines demonstrates that even a material that appears harmless at first glance can become an effective weapon if it is properly camouflaged and brought close to the target. Even small

charges integrated into energy systems are capable of causing large-scale destruction due to the physics of the process (steam boilers, locomotives, industrial equipment).



The enemy continues to use this experience to inflict casualties on both our soldiers and the civilian population. In this case, the device is disguised as a silicate brick.

It is a 30-mm cartridge with an electronic fuse triggered by changes in the magnetic field and changes in position, and having a self-destruction mode of approximately 30 days. The fuse is presumably an MA-1 from an IBM-0.2 round. K In addition, it is possible



that the enemy used p-type launchers designed for PTM-3 and PTM-1L mines.

But quite often ob at the same time, enemy sappers can and do make IEDs from any objects, as long as they have enough f imagination, and the sapper’s own expertise. The key point here is that the object being



camouflaged must blend in with the terrain, surrounding objects, and the environment at the site of deployment!

Therefore, our sappers must always be on high alert , keep a clear head, and be able to anticipate the enemy sapper’s actions in a given location...

For modern EOD specialists, the story of the coal mine offers several key lessons: the threat does not always take the form of conventional munitions; any object in the energy, transportation, or construction sectors (especially in light of the reconstruction of private homes, buildings, and other structures) can be potentially dangerous, and thorough analysis and preventive measures are critically important.

Technologies change, but the principles of sabotage remain the same, and the Confederation’s historical experience shows how ingenuity and camouflage can greatly increase the effectiveness of a limited charge. Today, as energy and transportation systems remain vulnerable, the history of the coal mine serves as a reminder of the need for

constant vigilance, a keen awareness of atypical threats, and the importance of understanding the past for the safe application of modern technologies.



"BEP-LD-M1" Non-Contact Electronic Detonator (Ukraine)

The electronic fuse ensures that munitions detonate in the air above the surface, which

significantly increases the blast radius of fragmentation munitions. It does not depend on direct impact contact with the target, the angle of impact, or the softness of the ground or water surface.

Upon activation of the electronic fuse, a self-diagnostic check of the internal systems is performed. The UAV operator receives a corresponding status indication, which guarantees the safety and operational readiness of the device during

subsequent operation. The presence of four safety mechanisms ensures protection against accidental detonation of the fuze even if the munition accidentally falls from the unmanned aerial vehicle from a height of up to 7 m.

Thanks to the specially designed adapters, the fuze is compatible with most 60-mm and 82-mm mines used on the front lines. The ability to independently set the munition's burst altitude before the UAV's combat mission ensures flexibility in its use in accordance with the assigned tasks. A protective cap with a weight ensures that the safety pin is automatically pulled out remotely upon the UAV's takeoff, without operator intervention.

Main Technical Characteristics of the Fuse:

Type: Non-contact, electronic, air-detonation.

Method of ammunition detonation: Electrical, using an electronic control system.

Compatibility: 60 mm and 82 mm artillery mines are designed for use with UAVs.

Detonation altitude above ground level: According to the set mode: Mode No. 1: 0.7 to 1.3 m (recommended for 60 mm and 82 mm mines). Mode No. 2: 2.5 to 3.2 m. Mode No. 3: 4.5 to 5.3 m.

Minimum munition drop altitude: Recommended minimum drop altitude for munitions equipped with the BEP-LD-M1 fuze: 70 m

Parameters: (length, diameter, weight) Length: 131 mm. Diameter: 57 mm. Weight of the armed fuze (maximum): 155 g

Temperature range: Operating temperature range: -30°C...+50°C.

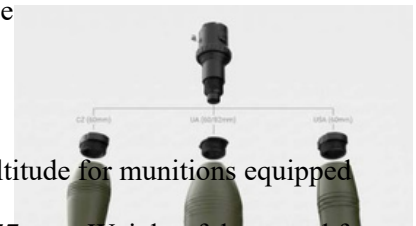

It is possible that the enemy, by making another adapter, could adapt it for use with engineering munitions

UDSh-U Standardized Smoke Grenade (Ukraine–USSR)

Not everything inside a TM-62M casing is a mine. It could also be a smoke grenade. If you need to create



a dense and sufficiently long-lasting smoke screen, **the UDSH** is used. This is **the Standardized Smoke Grenade**. It is housed in the casing of a TM-62M mine (“M” meaning metal). This smoke munition, like the TM-62M, is large and heavy, yet still quite portable. It allows for effective smoke coverage when smoke grenades and small smoke grenades are clearly insufficient. The UDSH is used to

provide a smoke screen to cover vehicles, positions, or important targets during an enemy attack. It is used during various offensive maneuvers, as well as during flanking maneuvers or retreats. In today’s operational environment, it can also be used to “smoke out” drones.

The UDSH casing, familiar to virtually everyone, comes from the most widely used Soviet anti-tank mine, the TM-62M. Only instead of explosives, the can is filled with a smoke-generating compound.

The UDSH is “standardized” because its casing is identical to that of the widely used mine. No separate production is required.

At the top center, where the fuse would normally be, there is a protruding disc with external threads protrudes. On the surface of this element is a diaphragm for regulating the release of smoke. Inside are the fuses: a mechanical one and an electrical one. In the transport position, the fuses and the diaphragm are covered by a screw cap (transport cap).



It is not difficult to visually distinguish the UDSH from the TM-62M:

First, the distinctive shape of the transport cap is hard to confuse with any of the fuses for the TM-62 family of mines. If the cap is unscrewed, the protrusion with the fuses is also hard to mistake for a fuse (*none of them have external threads on top*).

Second, the marking “UDSh” is visible on the side.

The product includes: The body.
Transport cap. Smoke-generating compound.
Ignition tablet. Mechanical fuse.
An electric fuse. A diaphragm.
Carrying handle made of webbing.



Main Technical Specifications

Diameter: 32 cm.
Weight of the smoke-generating device:
13.5 kg.
Weight of smoke-generating compound: 10.5 kg.

Instructions for use:

A) Place the device in the desired location. B) Unscrew the transport cap.
C) Remove the electrical tape securing and insulating the wire ends. D) Remove the safety split pin with the ring (pin).

During activation, keep your face, other body parts, and clothing away from the surface of the device. Strike it and move away, or manipulate the electrical wires from a safe distance.

If using the mechanical ignition method, remove the protective cap from the striker. Strike the exposed firing pin with a hard object, from top to bottom. You can use the top of the transport cap or any blunt, sturdy object at hand.

If you choose the electrical method, you'll need an external power source: a standard battery (1.5 V or higher) or a detonator. Connect the extension wires (*if you've extended them significantly, a single 1.5 V battery might not be enough to break the circuit, so bring extra: 4.5 V, 9 V, or a battery pack*). Close the circuit at the power source's terminals.

If you're using an electronic fuse, you don't need to remove the cotter pin. But it's just a habit. Sometimes, in peacetime, they require you to turn in receipts for record-keeping... So it's better to remove it, but don't take the protective cap off the firing pin, so you don't accidentally activate the charge by hitting (or pressing) it while working on the wires.

With the mechanical method, the burn-in time to maximum intensity is 30 seconds. With an electric igniter: 10 seconds.

Initially, there is intense fire and sparks. *This is precisely why you should not put your face near it.* Smoke begins to form, the activity intensifies, and the flame gradually dies down. Therefore, it is advisable to stay at least 25 m away from an active smoke grenade. If you must operate closer to it, or directly in the smoke, respiratory protection is mandatory. According to standard procedures, this means a gas mask or respirator. However, in emergency combat situations, cover your mouth and nose however you can—even with your elbow or clothing—and get out of the smoke. It's not extremely dangerous, but prolonged exposure to the smoke can cause mild to moderate irritation.

The smoke is white-gray in color, with a smoke duration of 8–10 minutes. However, this depends on wind strength, and on average, it forms an impenetrable smoke screen extending 100–150 m.

Ignition methods

The most basic method: manually via a mechanical fuse—used extremely rarely. Usually during training exercises. In combat conditions, when the sky is full of enemy drones, standing in open terrain is an unjustifiable risk. Furthermore, with the impact method, the grenade takes



on the move when a drone is spotted). If necessary, they supply power to the electric fuse to activate the UDSH.

Remotely, via a radio channel. A special device is placed on the drone and connected to the fuse wires. This is a radio receiver with an antenna, combined with a simple control board. Upon receiving the desired signal from the radio transmitter, an electrical pulse is sent to the fuse and the UDSH begins to operate.

Naturally, these two remote methods are the most common in modern combat operations.

An Enemy Remote-Detonation Device

It's useful to be able to quickly tell the difference between a mine and a harmless smoke grenade. That said, of course, you must remain vigilant in a combat zone.



The smoke grenade itself will not explode. However, a booby trap or some kind of improvised explosive device may be hidden beneath it.

If you need to remove the smoke grenade, you must first check for an external trap. Wrap a loop at the end of a long rope (slings) around the body of the grenade. Step back and take cover at least 25–30 m away. Then pull the smoke grenade away from its location.

If it might be useful, first inspect the body for any external tampering. If everything looks normal, check further: is the cap in place, or has it been twisted off? If the cap is in place, there's a risk that there's some kind of explosive nastiness underneath it as well. The risk is minimal, but not zero. Therefore, either move the mine to other explosive ordnance disposal sites, or devise clever ways to twist the cap off remotely...

If the cap is missing and the casing shows no signs of tampering, you can use the trophy for your own purposes, as intended.

